

INDEX OF ILLUSTRATIONS

I

COMPONENTS	NO. OF ILLUSTRATION	DESCRIPTION
ENGINE	1 2 3 4 5 6 7 8 9 10 11 12 13 14 14A 15 16 17 18 19 20 21	Engine - gearbox assembly. Adjustments: ignition and timing. Distributor. Checking the centrifugal advance. Ignition coil (testing). Petrol pump (vertical section). Petrol pump: checking for leakages. Carburettor: sections and outside views. Air cleaner silencer: section. Removal and fitting of valves. Horizontal section. Vertical section. Longitudinal section. Disassembling a piston and a small end bearing. Fitting the oil seal. Fitting the cylinder. Expanding the rocker push rod housing tube. Checking the oil pressure. Lifting the engine. Stand for engine. Calibration of spring. Oil circulation (pump, breather valve). Various tools.
CLUTCH	22 23 24	Various views. Clutch adjustment. Clutch adjustment.
GEARBOX	25 26 27 28 29 29A 29B 30 31 32 33 33A 34 34A 35 36 37 38	Change speed levers. Longitudinal section. Stand (gearbox in horizontal position). Section of the brake backplate (aluminium). Brake backplate (aluminium). Section of the brake backplate (steel). Brake backplate (steel). Selector shaft. Disassembling the reverse pinion shaft and the primary shaft bearing. Section of the bevel pinion shaft and the reverse pinion shaft, position of the synchronising circlip. Section of the primary shaft and the mainshaft. Second and third speed sliding gears and the speedometer drive pinion. Section of the differential. Clutch housing with pressed steel fork. Extraction of the differential bearing. Tightening the ring nut on the brake backplate. Universal joint (gearbox end). Assembly of the brake shoes.

INDEX OF ILLUSTRATIONS

COMPONENTS	NO. OF ILLUSTRATION	DESCRIPTION
GEARBOX (Continued)	39 40 41 42 43 44 45 46 47 48	Grinding the brake drums. Fitting the rear bearing. Holding the intermediate shaft. Adjustment of the crown wheel and bevel pinion. Adjustment of the selector forks. Adjustment of the differential bearing (Measurement). Adjustment of the differential bearing (Stand). Centering the brake linings. Position of gears for each speed. Position of gears for each speed.
FRONT AXLE STEERING	49 50 51 52 53 54 55 56 57 58 58A 59 60 61 62 63	Section of hub of arm. Assembly of the friction disc. Assembly of the arm and friction disc. Raising the vehicle. Section of hub and king pin. Various tools. Removing and fitting the king pin. Checking an arm. Section of the steering gear. Section of the steering gear (through the pinion). Removal of the steering wheel. Stand for axle assembly. Various tools. Removal of the interior bearing of the axle crossmember. Various tools. Universal joint - wheel end.
REAR AXLE	49 50 51 64 65 66 67 68 69 70 71	Section of hub of arm. Assembly of the friction discs. Assembly of the arm and friction disc. Section of the hub and brake drum. Brake backplate. Various tools. Riveting the brake cam. Locking the wheel studs. Grinding the brake drums. Centering the brake linings. Checking an arm.
BRAKES	72	Section of master cylinder.
SUSPENSION	73 74 75	Section of a suspension unit. Adjusting the position of a suspension unit. Inertia damper.

INDEX OF ILLUSTRATIONS

COMPONENTS	NO. OF ILLUSTRATION	DESCRIPTION
ELECTRICAL	76 77 78 78A 78B 79 80 81 82 83 84 85 85A 86 86A	Section of windscreen wiper drive. Dynamo: longitudinal section (3 screw fixing). Dynamo: cross section (3 screw fixing). Dynamo: longitudinal section (2 screw fixing). Dynamo: cross section (2 screw fixing). Various tools. Fitting the coils and pole pieces. Dynamo bench test. Regulators (diagrams). Regulator tests. Wiring diagram. DUCELLIER Starter: longitudinal section. PARIS-RHONE Starter: longitudinal section. DUCELLIER Starter: assembly of the induction coils and brushes. PARIS-RHONE Starter: assembly of the induction coils and brushes.
ADJUSTMENTS	87 88 88A 88B 89 90 91 92 93	Checking caster and camber angles. Checking caster and camber angles of pivot. Checking positions of arms. Checking position of arm (tools). Checking valve timing. Checking heights. Checking wheels. Checking balance of wheels. Adjustment of headlamps.
CHASSIS	94 95	Principal dimensions. Checking side members.
LUBRICATION	96	Lubrication points.

ENGINE

ENGINE-GEARBOX ASSEMBLY

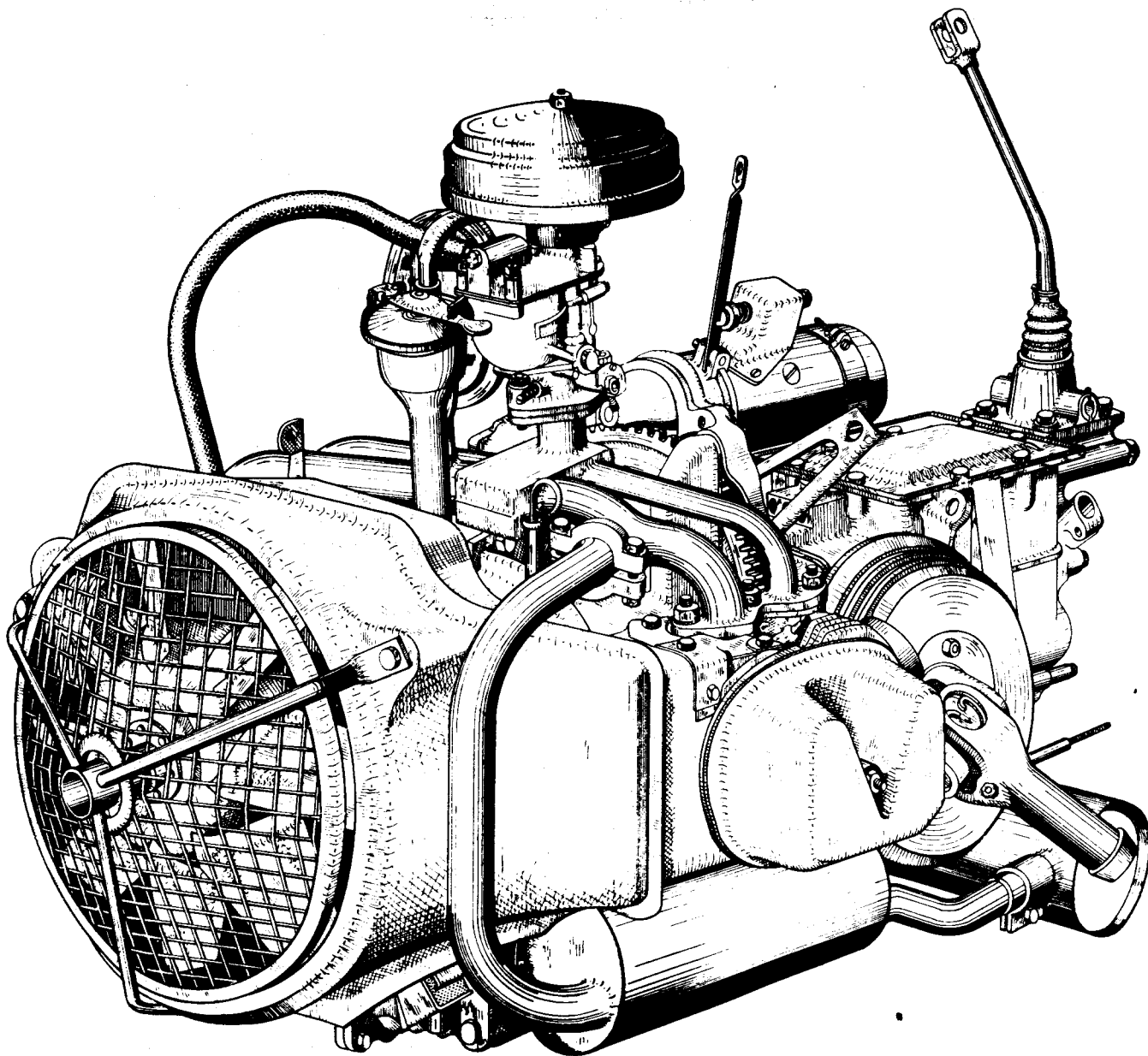

Fig. 1 - SETTING OF INITIAL ADVANCE

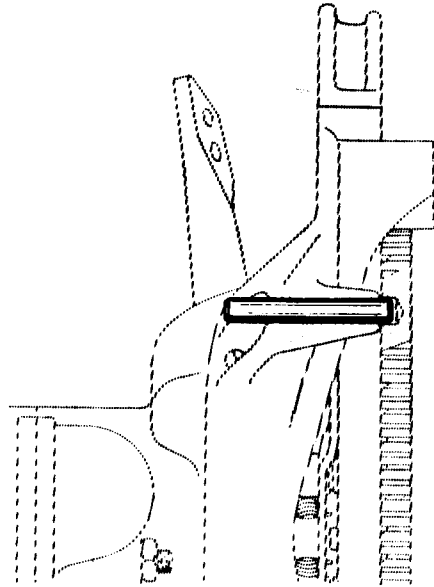

Fig. 2 - FITTING THE TIMING WHEELS

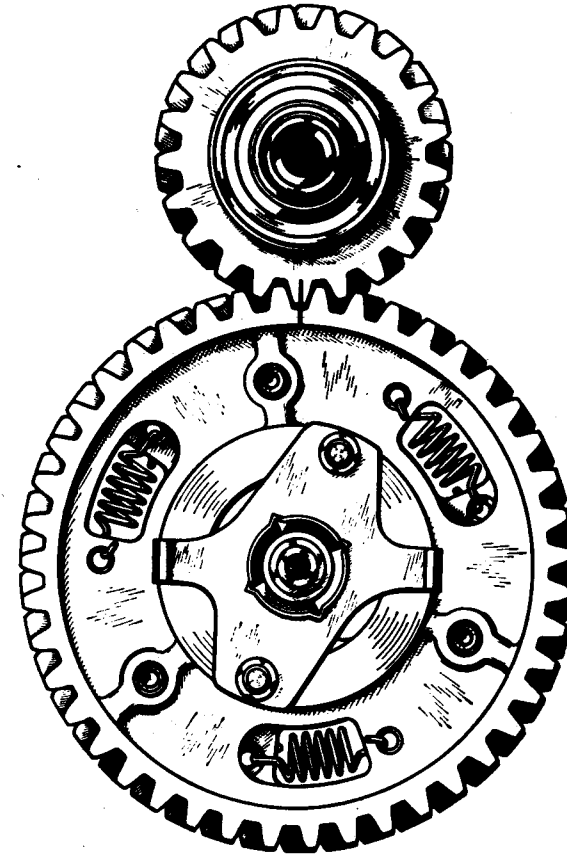

Fig. 3 - DETAILS OF TEETH



Fig. 4

THE TOOTH MARKED BY A CENTRE POP SHOULD COME IN THIS ZONE

DOWEL HOLE

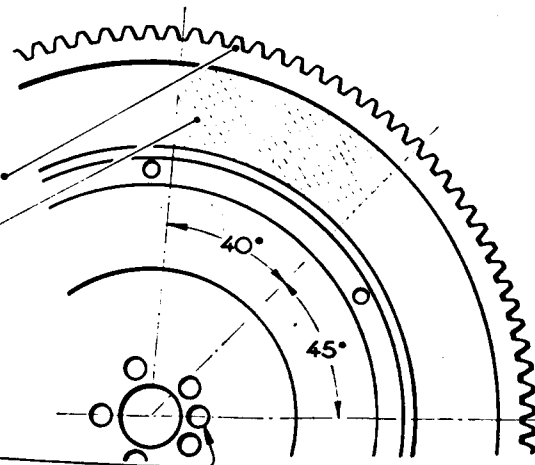

DISTRIBUTOR

Fig. 1 SECTION

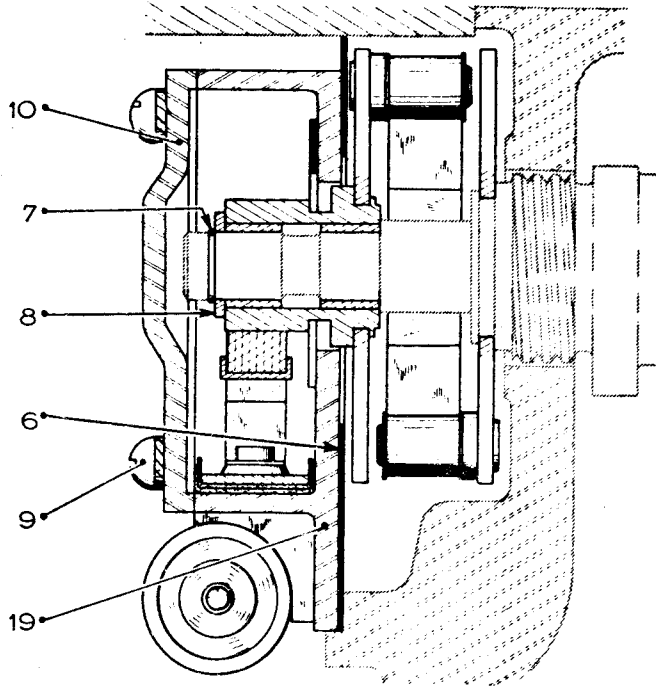

Fig. 2 FRONT VIEW

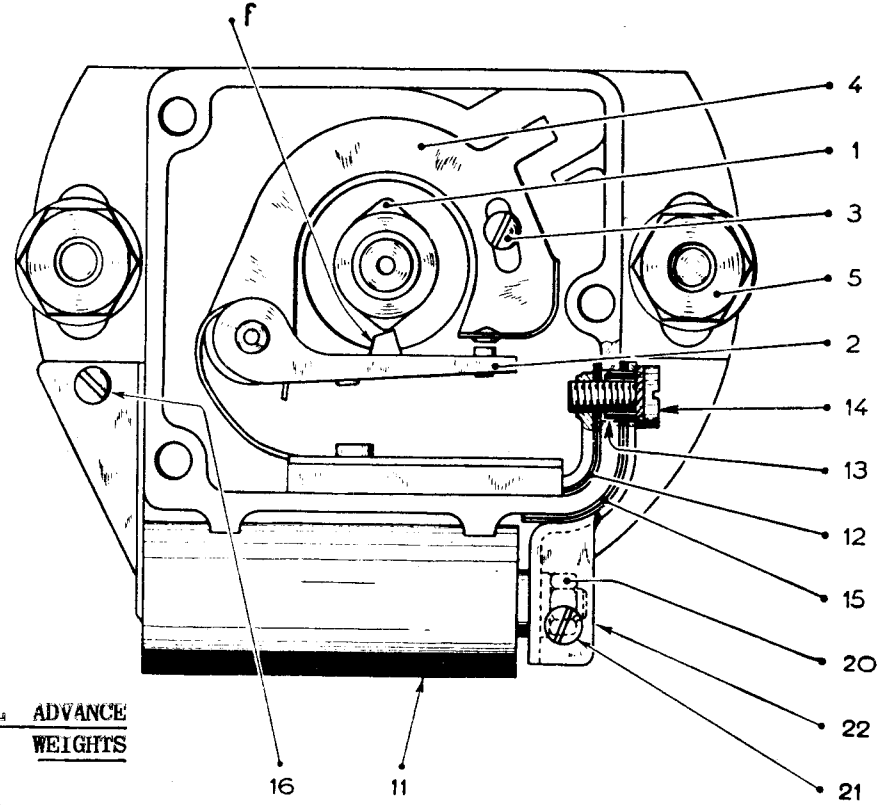
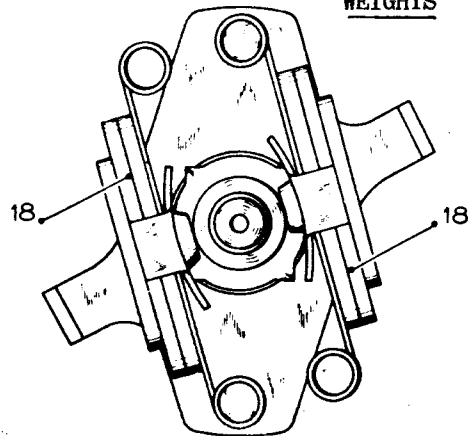
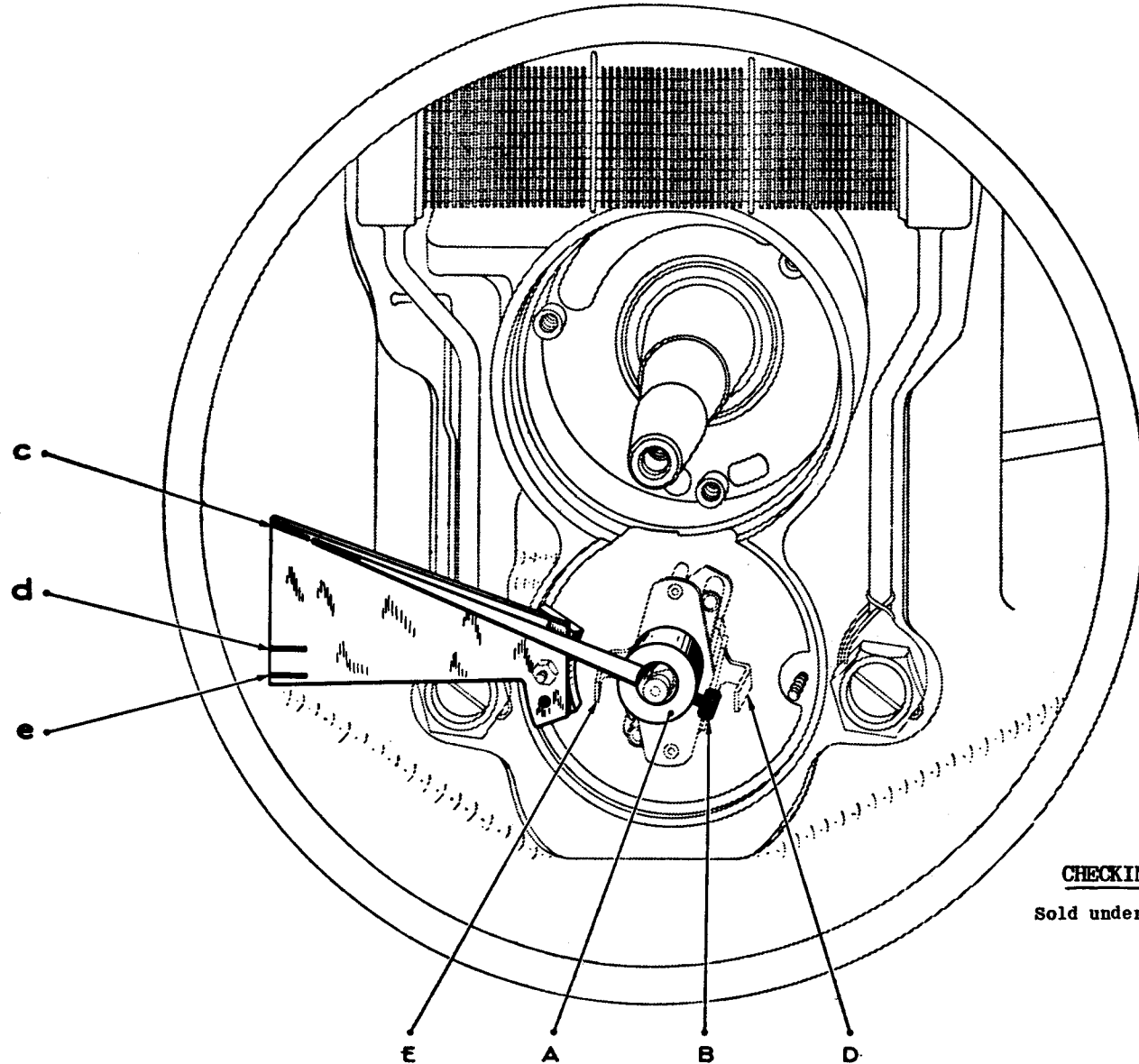

Fig. 3 CENTRIFUGAL ADVANCE WEIGHTS



— ENGINE —

— CHECKING THE CENTRIFUGAL ADVANCE —



CHECKING FIXTURE

Sold under No. 1692-VA

IGNITION COIL

Fig.1 - ASSEMBLY OF A SECONDARY TERMINAL

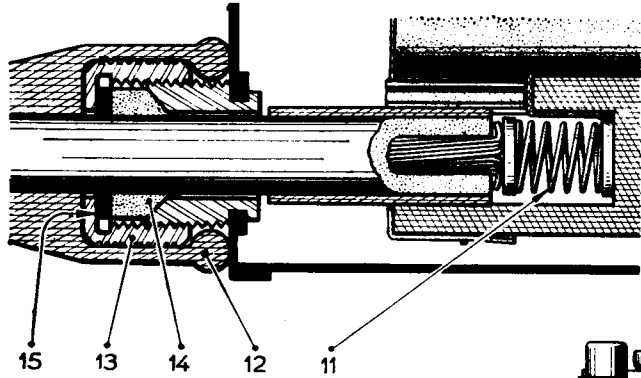
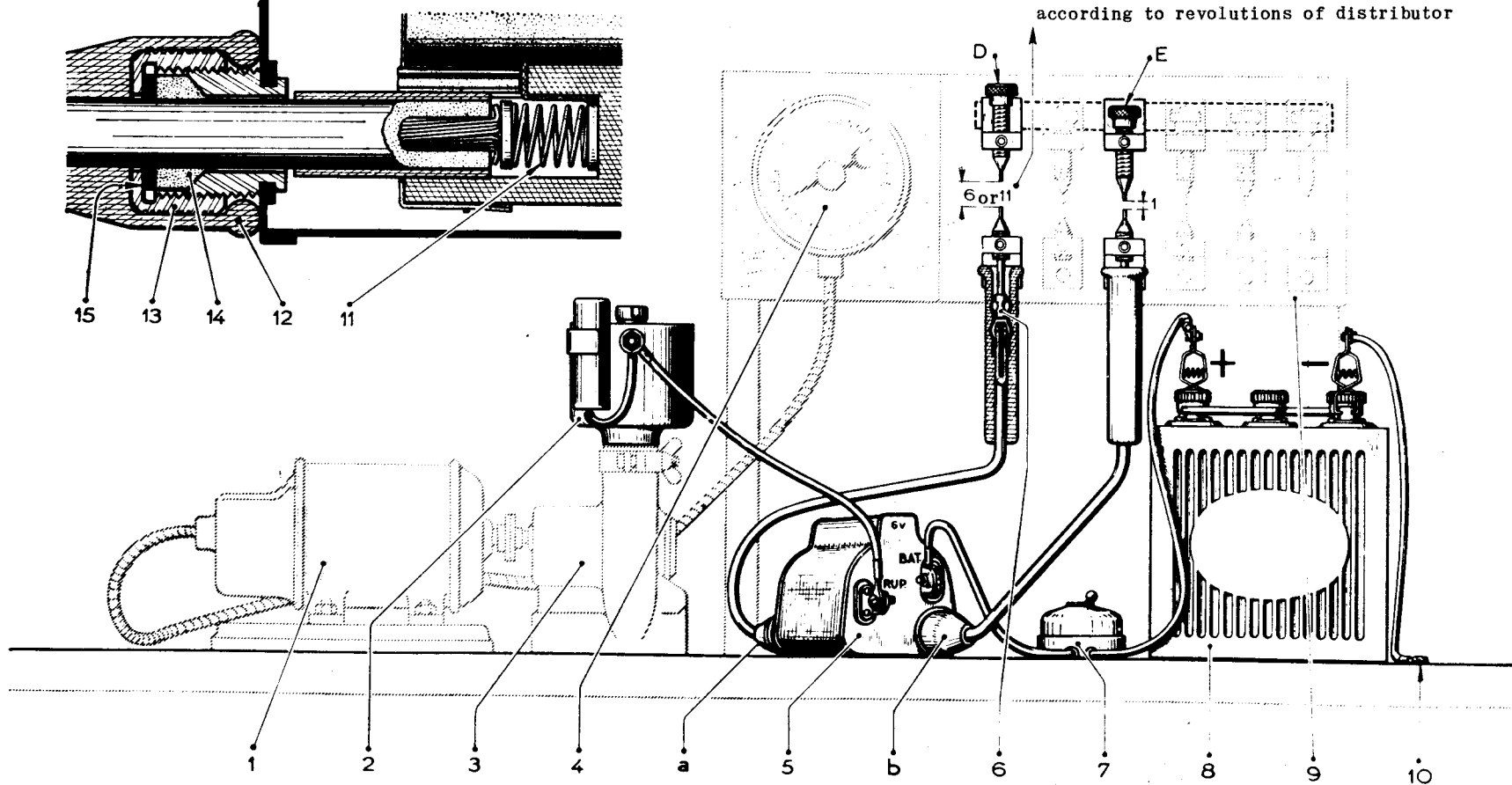

Fig.2 - CHECKING THE COIL



- 1 DRIVING MOTOR
- 2 4-CYLINDER DISTRIBUTOR WITH ITS CONDENSOR
- 3 RIGHT ANGLE DRIVE FOR DISTRIBUTOR
- 4 TACHOMETER
- 5 COIL

- 6 SPARKING PLUG TERMINAL CONNECTED TO SPARK-GAP
- 7 SWITCH ON PRIMARY CIRCUIT
- 8 6V BATTERY
- 9 TEST BOARD
- 10 EARTH CONNECTION FROM BATTERY

— PETROL PUMP —

— VERTICAL SECTION —

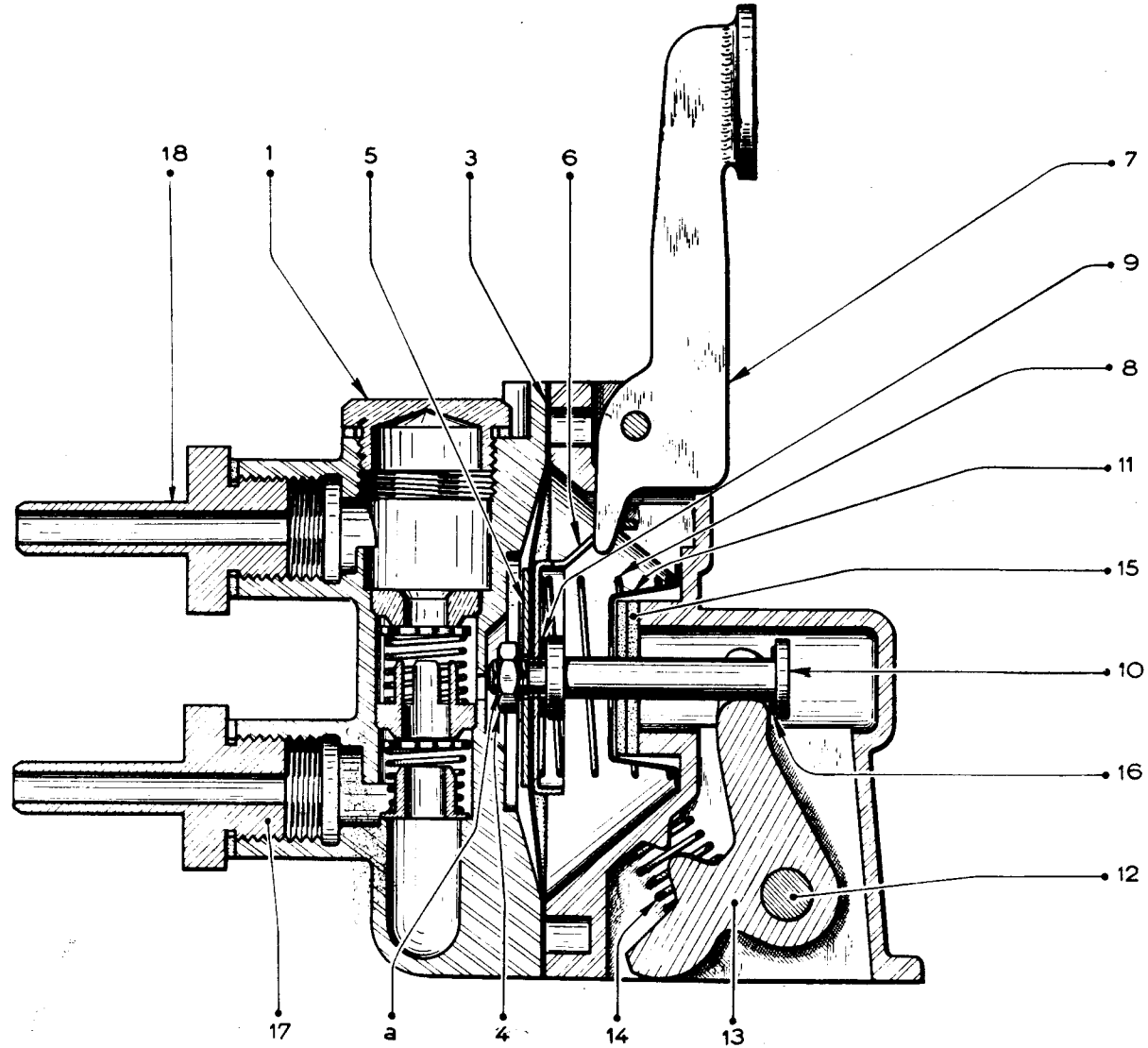

CHECKING FOR LEAKAGE

BAD FITTING
LEAKS FROM THE FITTING OF THE PUMP BODY

BLOW IN COMPRESSED AIR AT 100
TO 300 G. THROUGH THE INLET
PIPE.

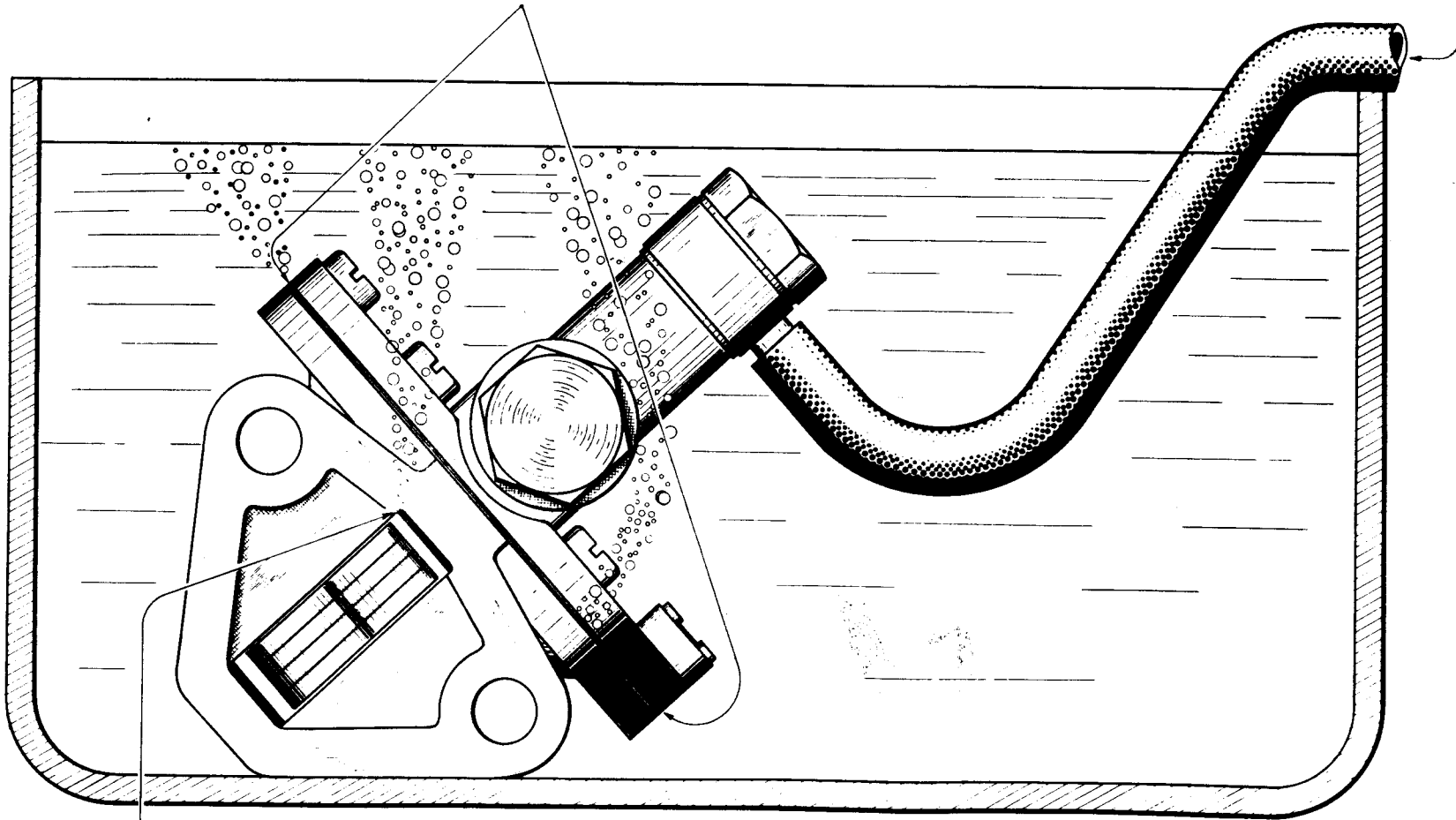

DEFECTIVE DIAPHRAGM
LEAK THROUGH THE HOLE FOR THE OPERATING LEVER

SECTION AND OUTSIDE VIEWS

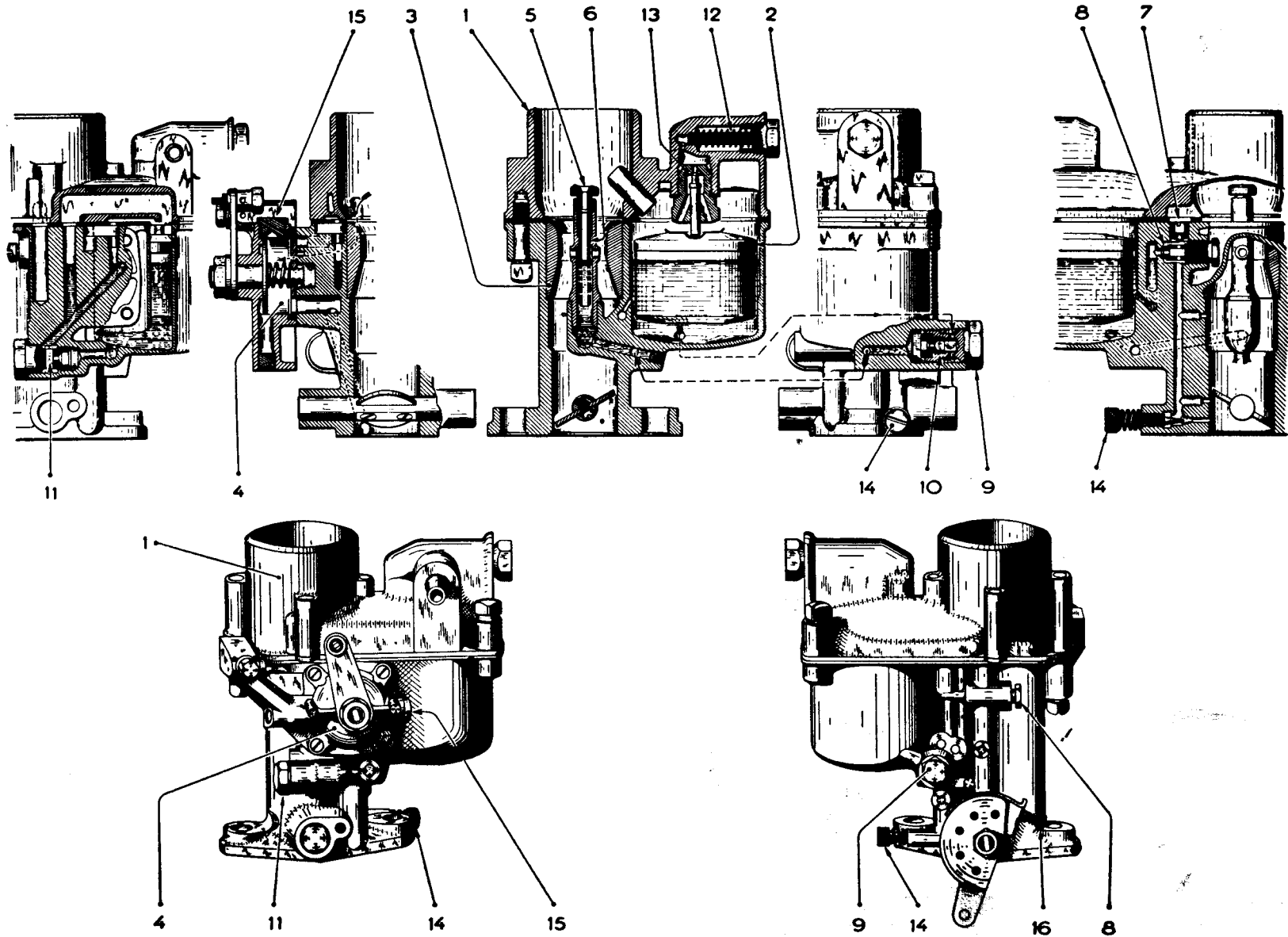

AIR CLEANER-SILENCER

SECTION

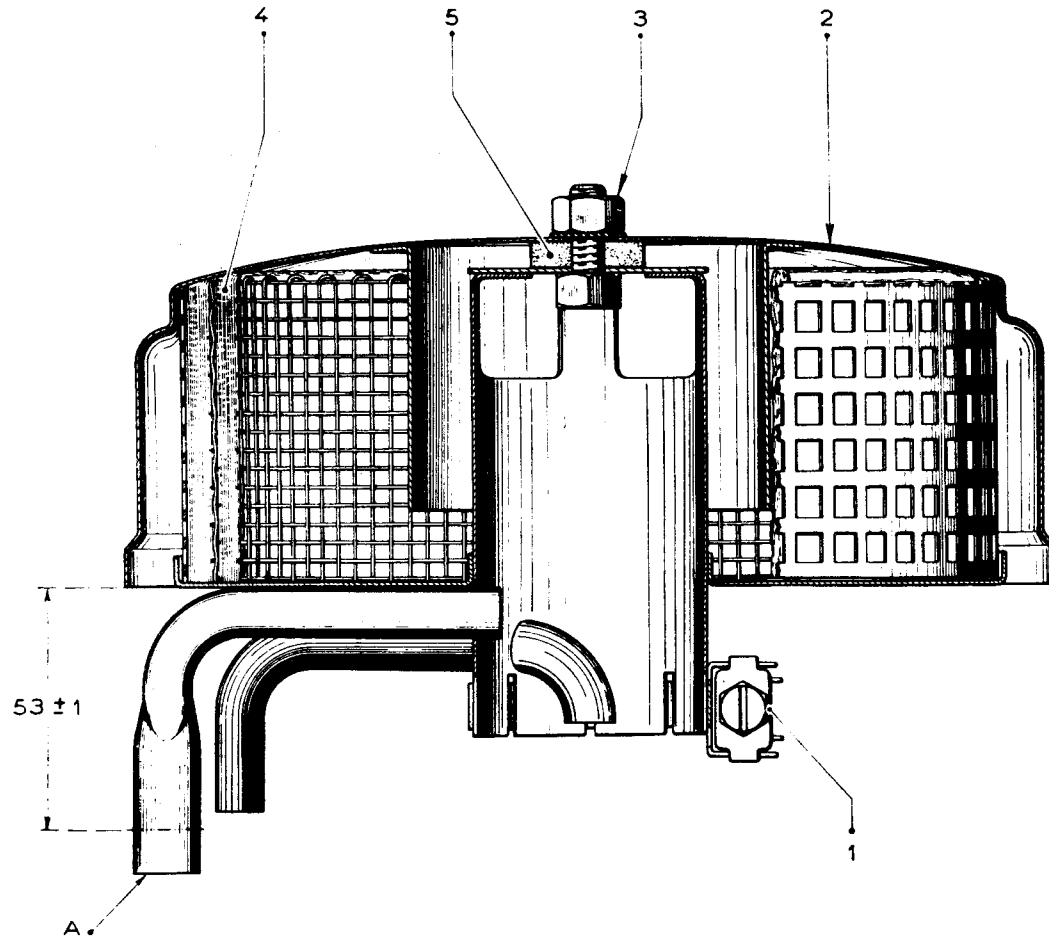

REMOVAL AND FITTING OF VALVES

Fig. 1

SPRING COMPRESSOR

Sold under No. 1612 VA

Fig. 2

Fig. 3

DETAILS OF THE LOCKING OF THE SPRING COP

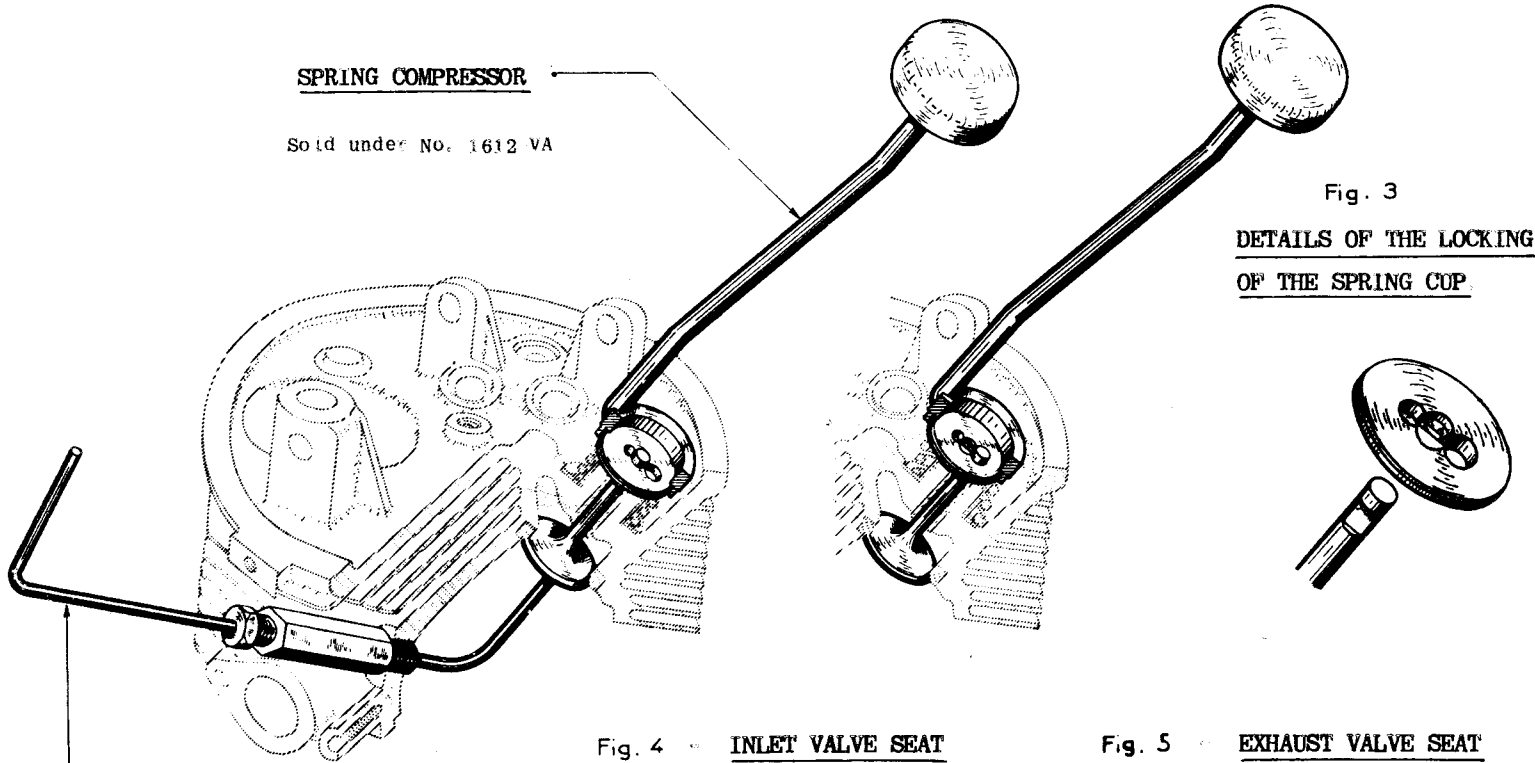

VALVE RETAINING TOOL

Sold under No. 1609 VA

Fig. 4 INLET VALVE SEAT

Fig. 5 EXHAUST VALVE SEAT

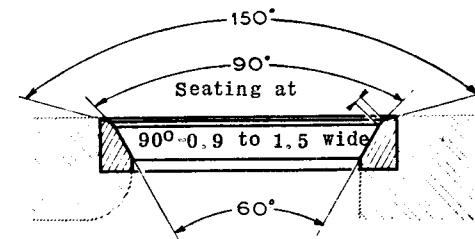
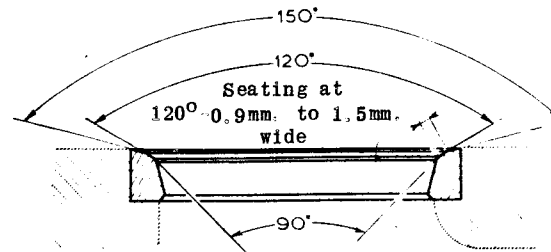

ENGINE

HORIZONTAL SECTION

Fig. 1

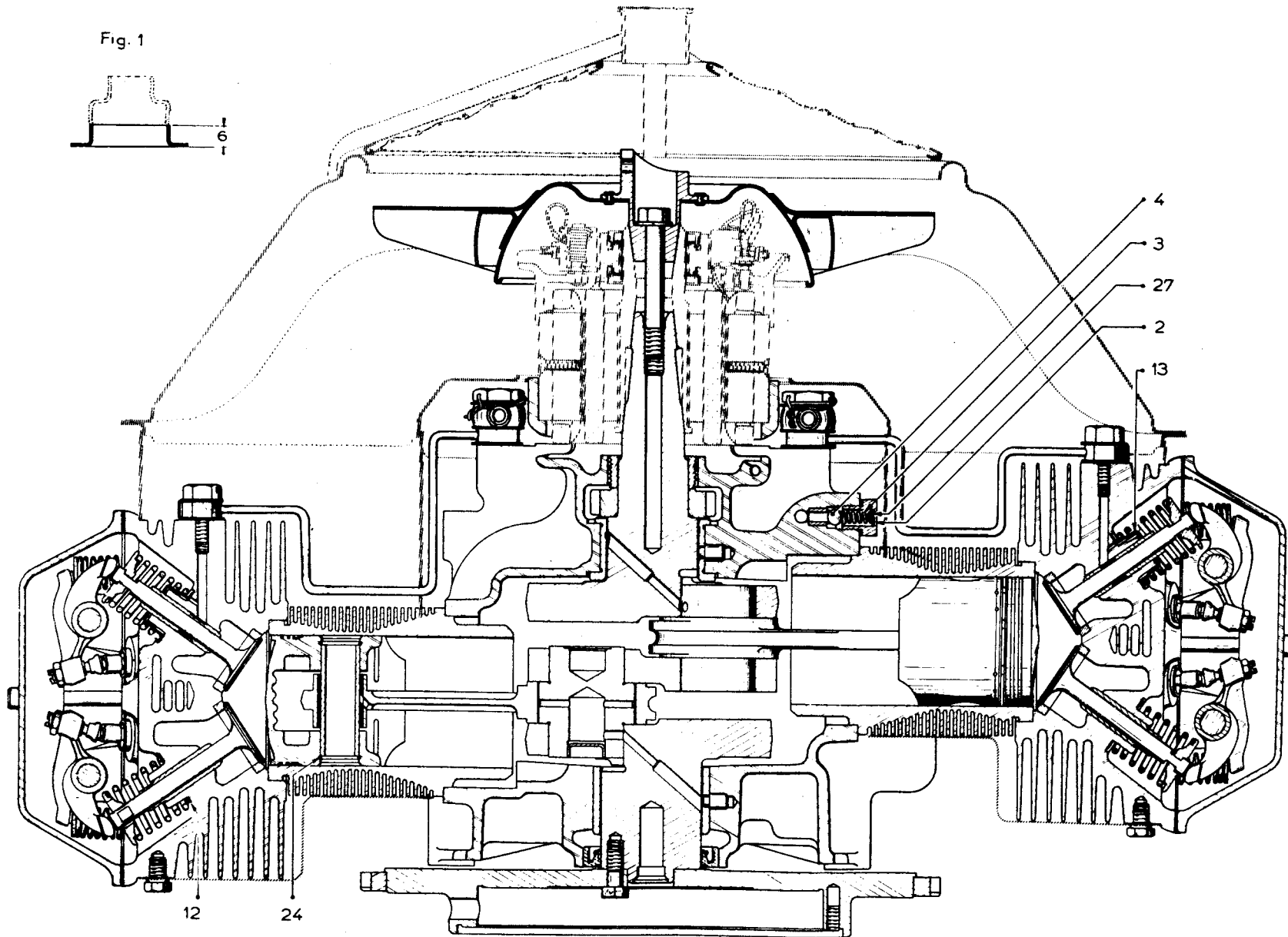

— ENGINE —

— VERTICAL SECTION —

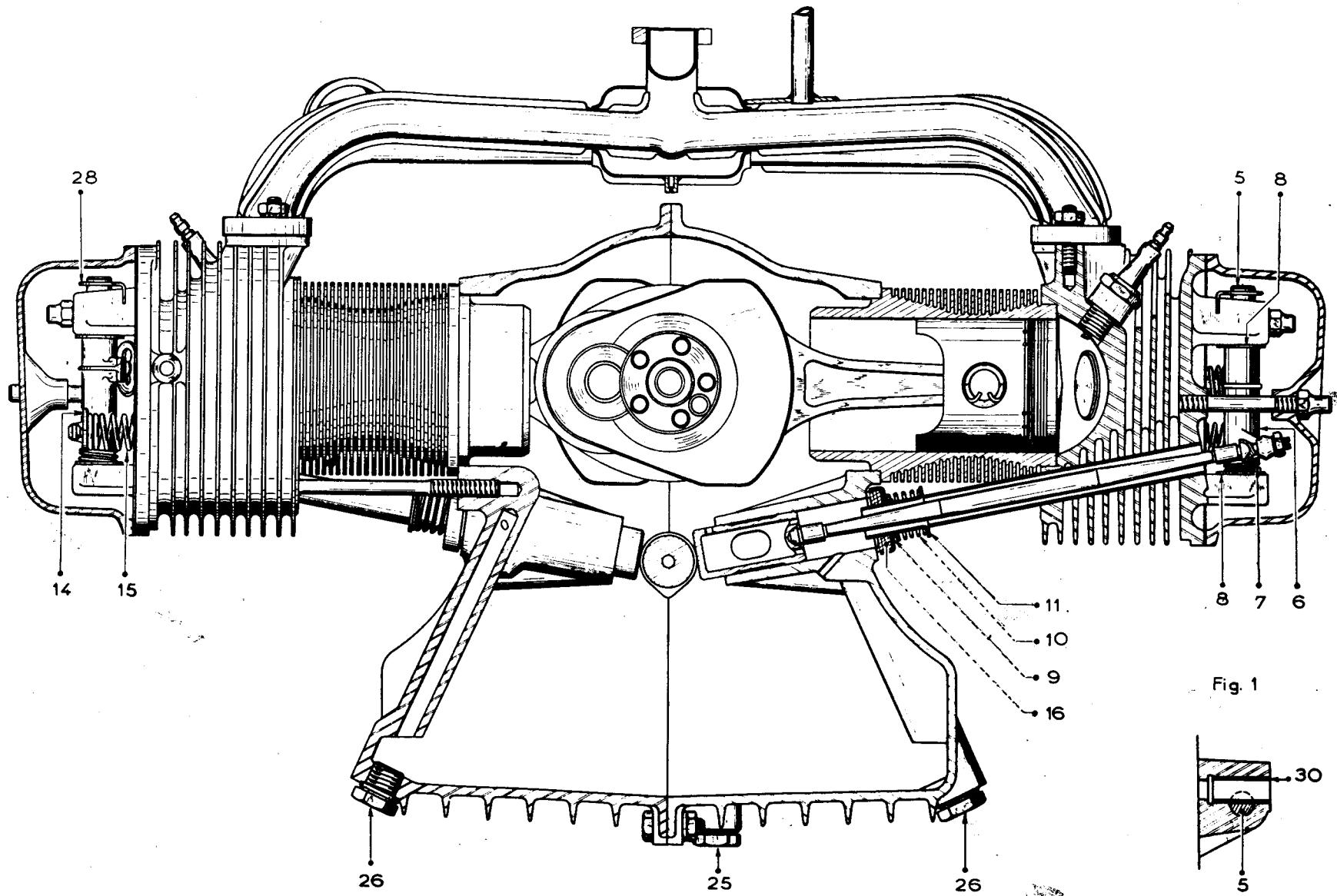

LONGITUDINAL SECTION

Fig 1

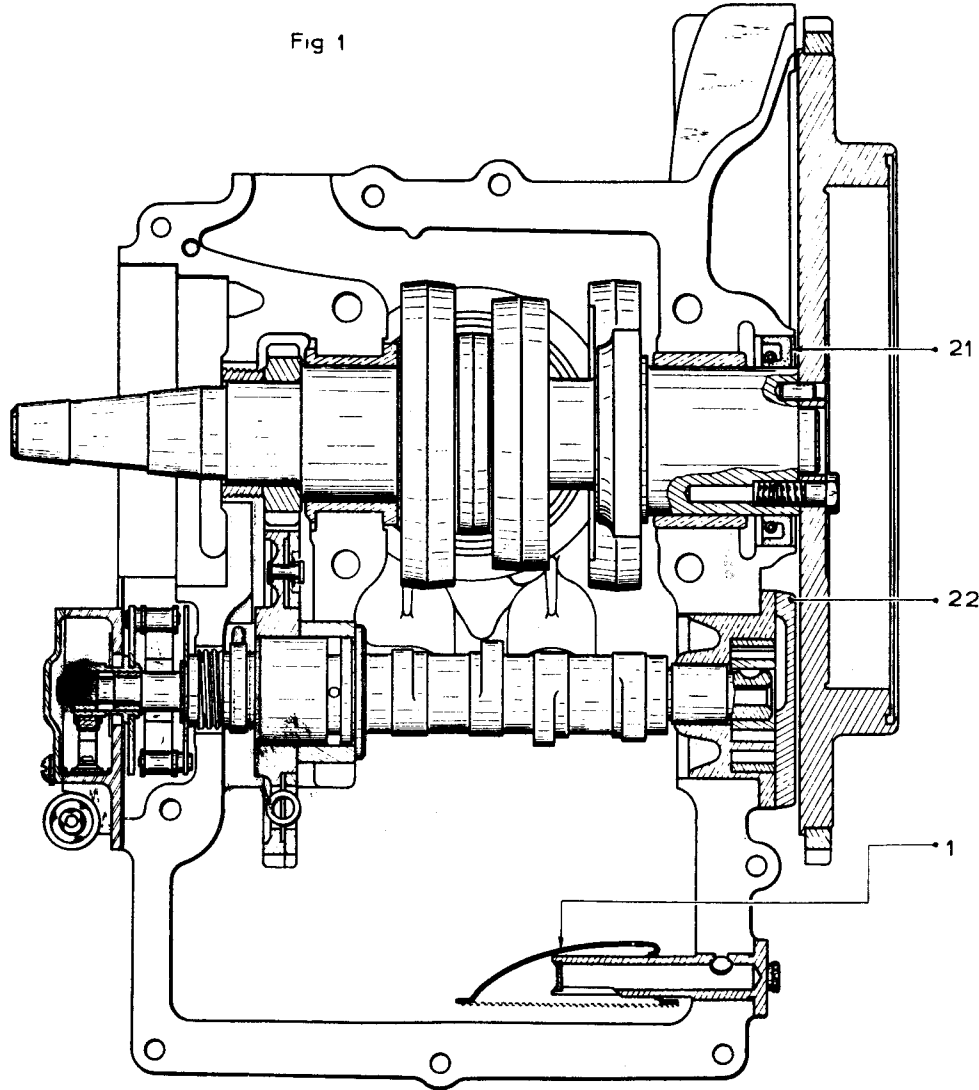

Fig. 2

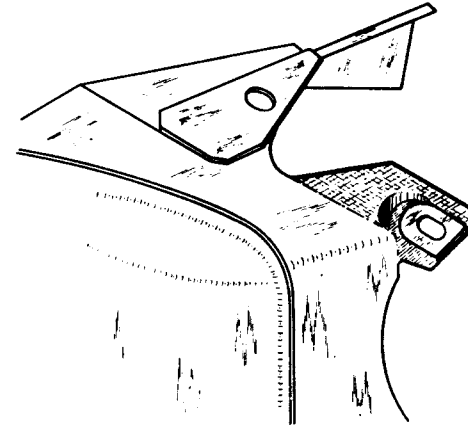
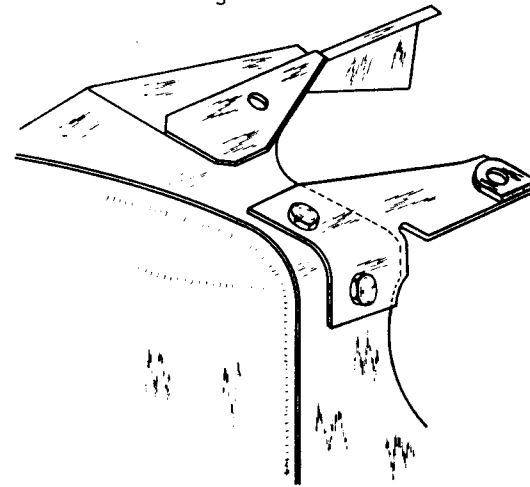

Fig. 3



DISASSEMBLY OF A PISTON

Fig. 1 - REMOVAL OF THE GUDGEON PIN

Fig 2 - REMOVAL OF THE CONNECTING ROD SMALL END BUSH

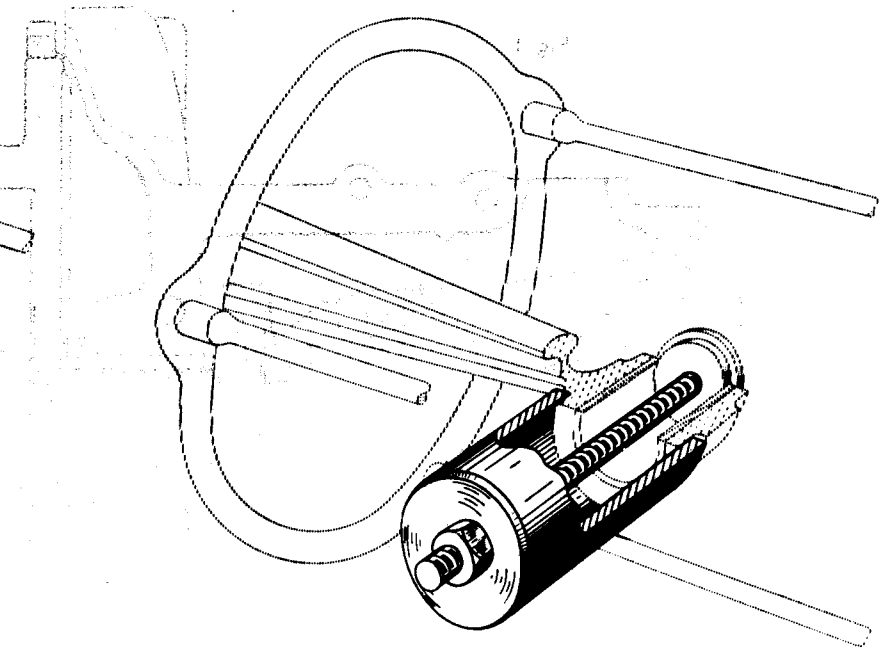
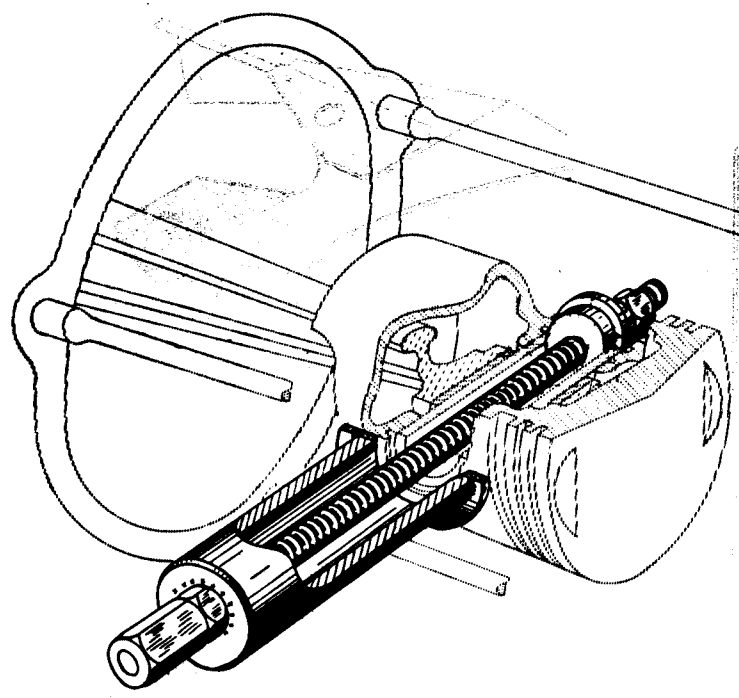
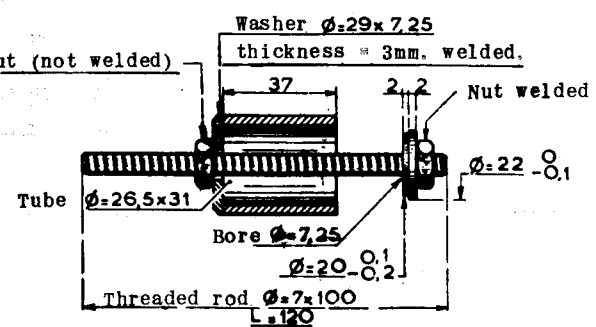
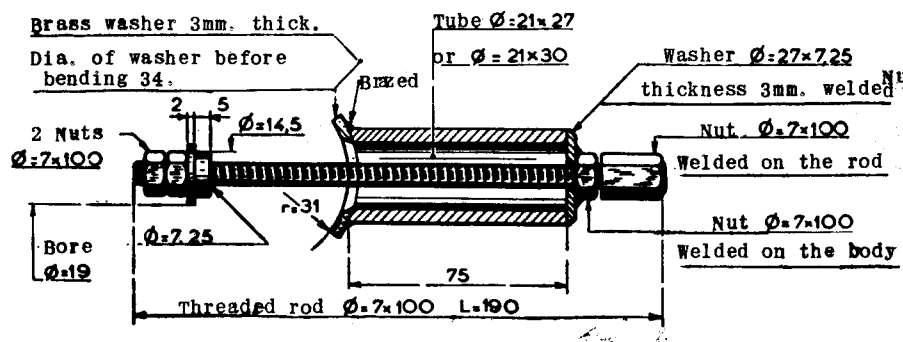

Fig. 3 - GUDGEON PIN EXTRACTOR MR. 3682-10

Fig. 4 - SMALL END BUSH EXTRACTOR MR. 3682-20

Not sold

Not sold



FITTING THE OIL SEAL

Fig. 1 - METHOD OF USE

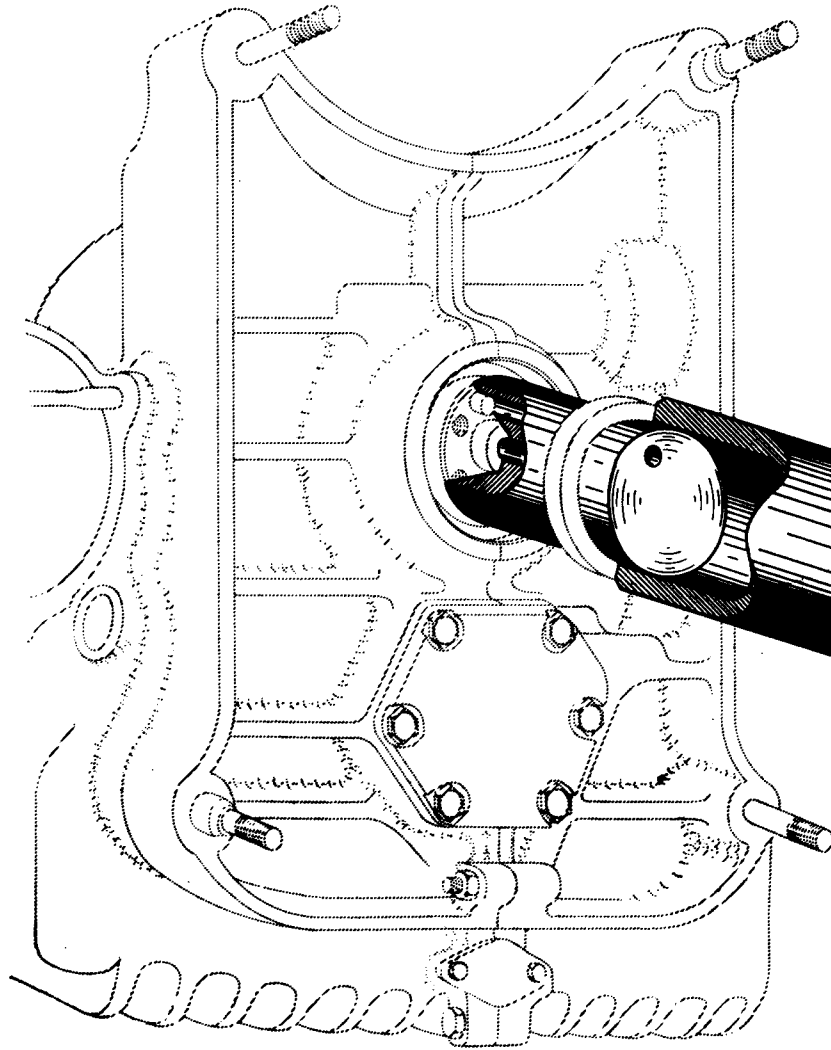
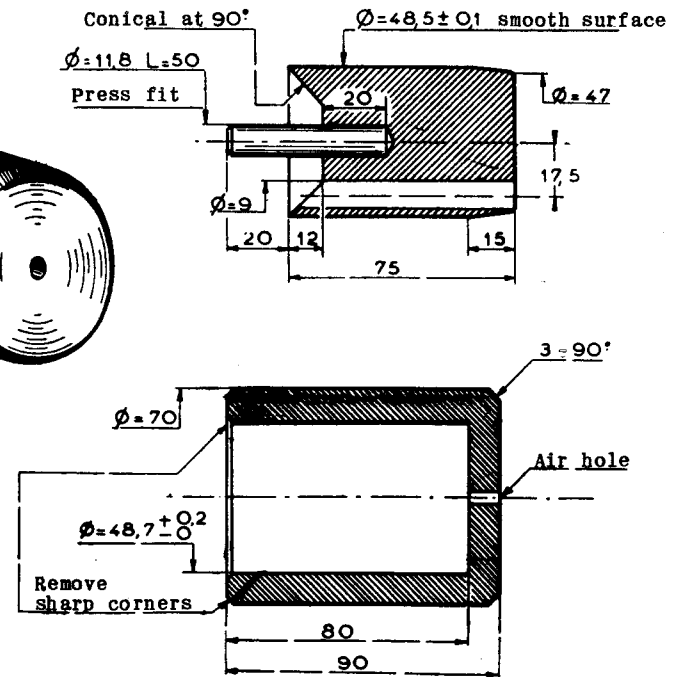

Fig. 2 - TOOL MR. 3754

Not sold



FITTING THE CYLINDER

EXPANDING THE ROCKER PUSH-ROD HOUSING TUBE

Fig. 1 - USE OF THE PISTON RING GUIDE

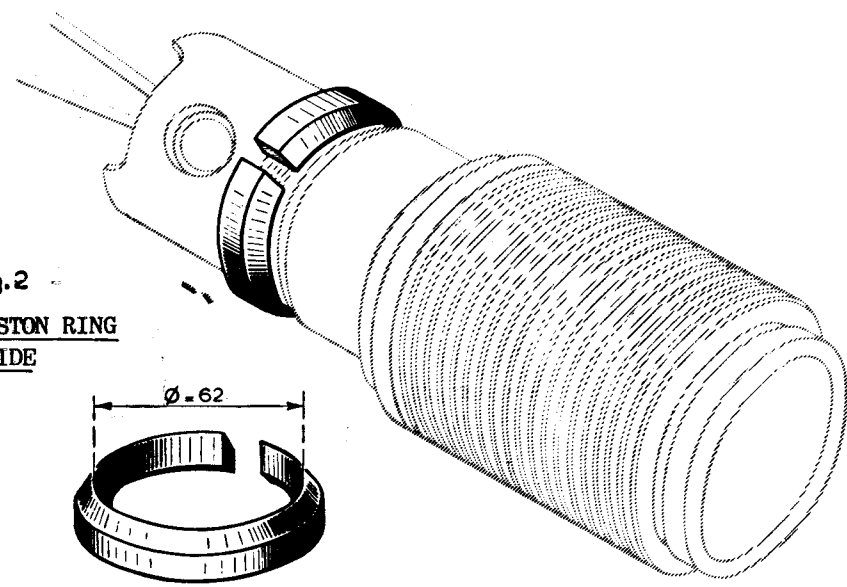
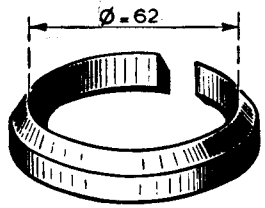

Fig. 2 - PISTON RING GUIDE



Sold under No. 1659 VA

Fig. 4 - EXPANDER

Sold under No. 1605 VA



Fig. 3 - EXPANDING

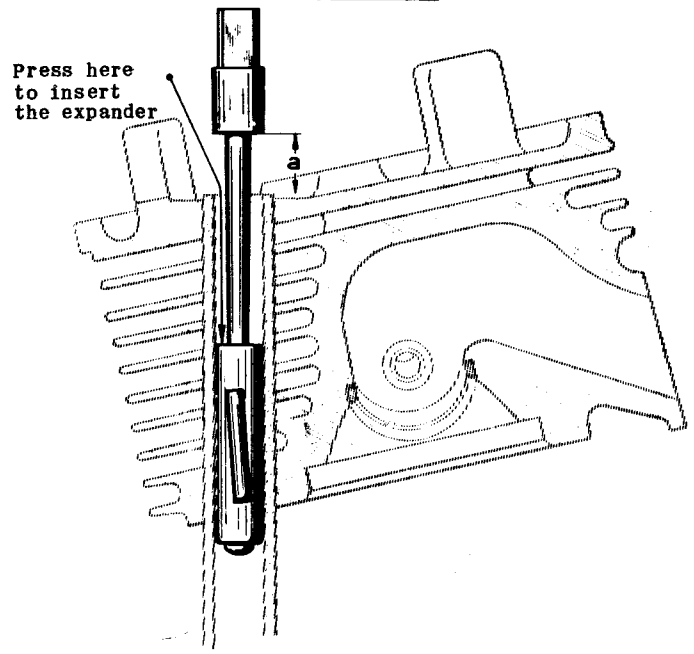
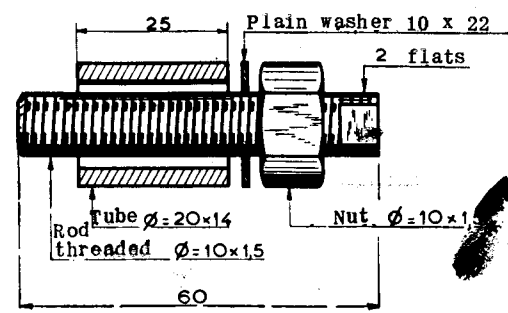

Fig. 5 - EXTRACTOR MR. 3682-50

Not sold



CHECKING THE OIL PRESSURE

Fig. 1 - METHOD OF USING UNION

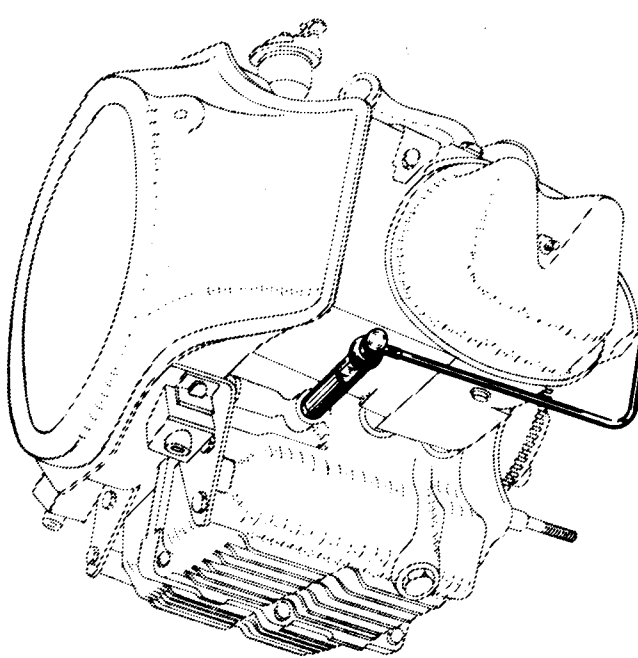

Fig. 2

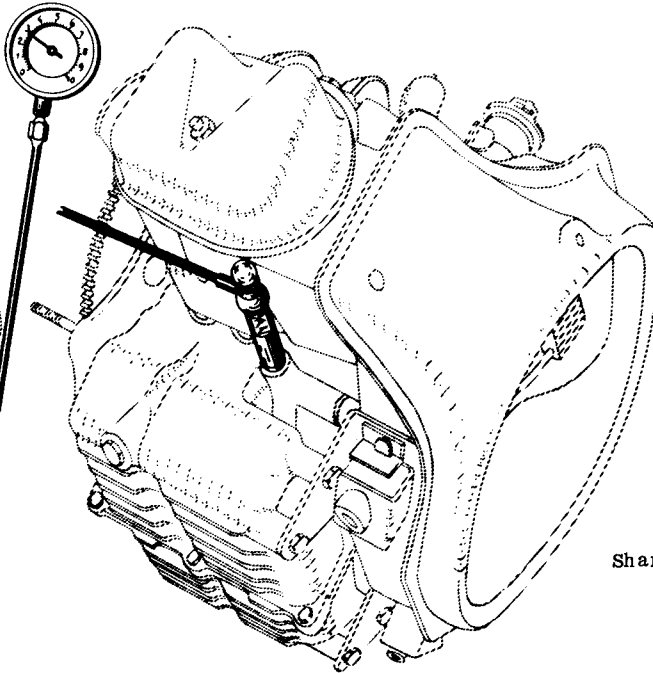
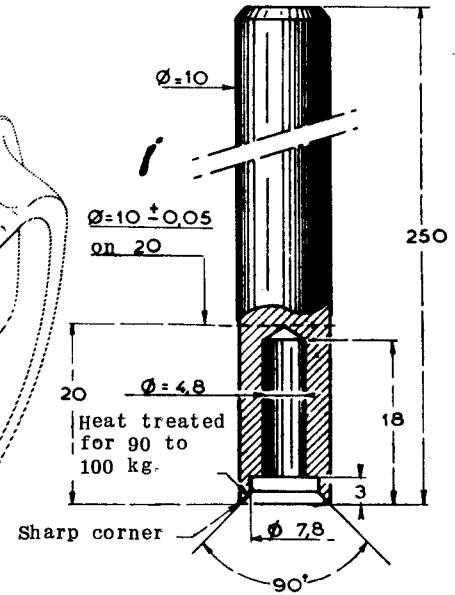

Fig. 5 - CLOSING PUNCH

Not sold



DOWEL FOR CLOSING PUNCH

Pressed into the punch

Fig. 3 - UNION MR. 3705

Not sold

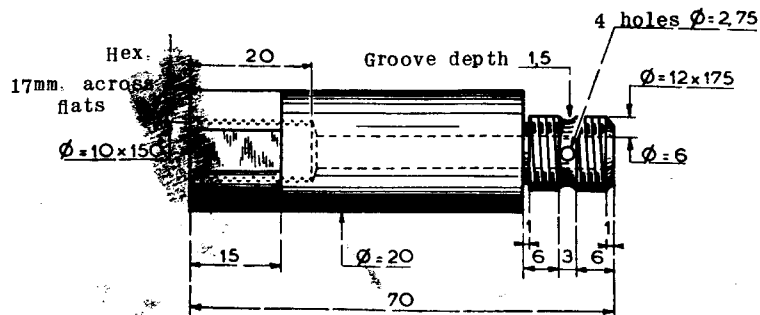
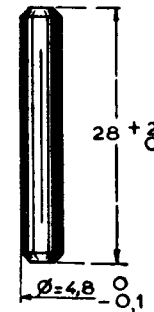
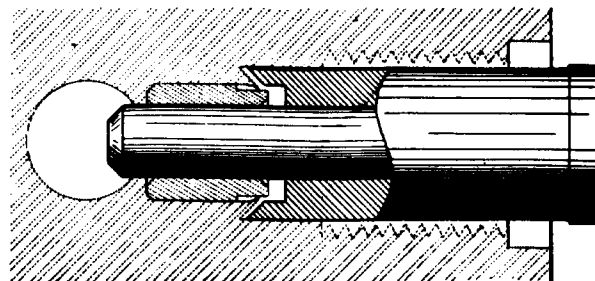

Fig. 4



— ENGINE —

— LIFTING THE ENGINE —

CHAIN SLING
Sold under No. 1619-VA

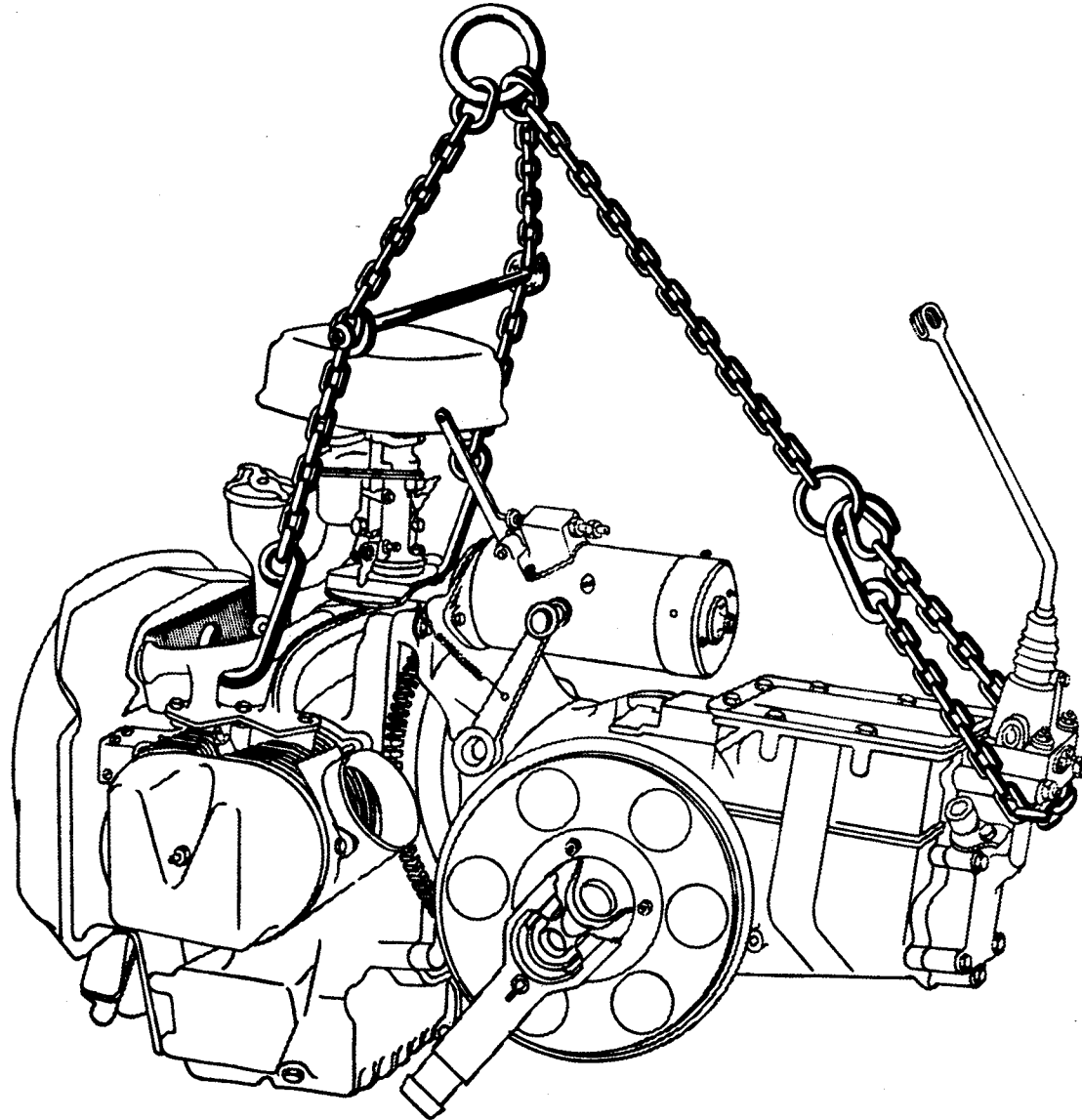

— ENGINE STAND —

USING THE STAND

FOR DIMENSIONS CONSULT OUR SERVICE DEPARTMENT

Fig. 1

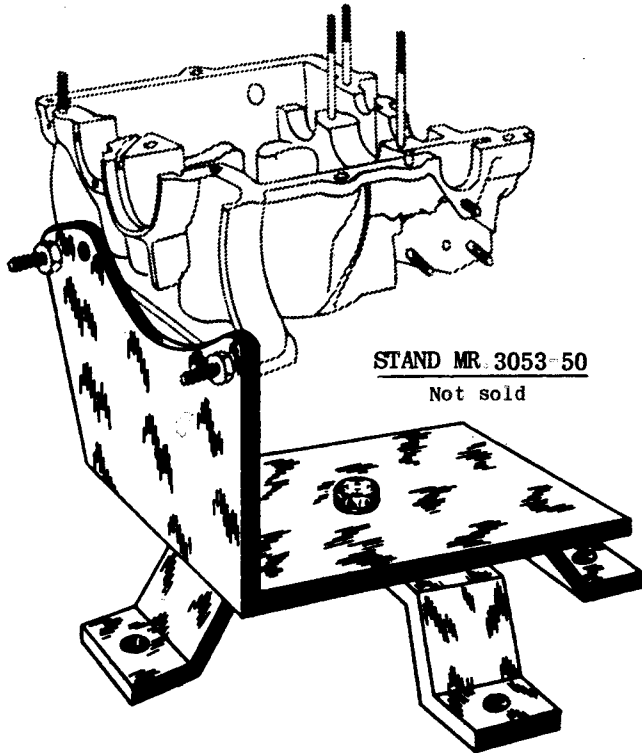
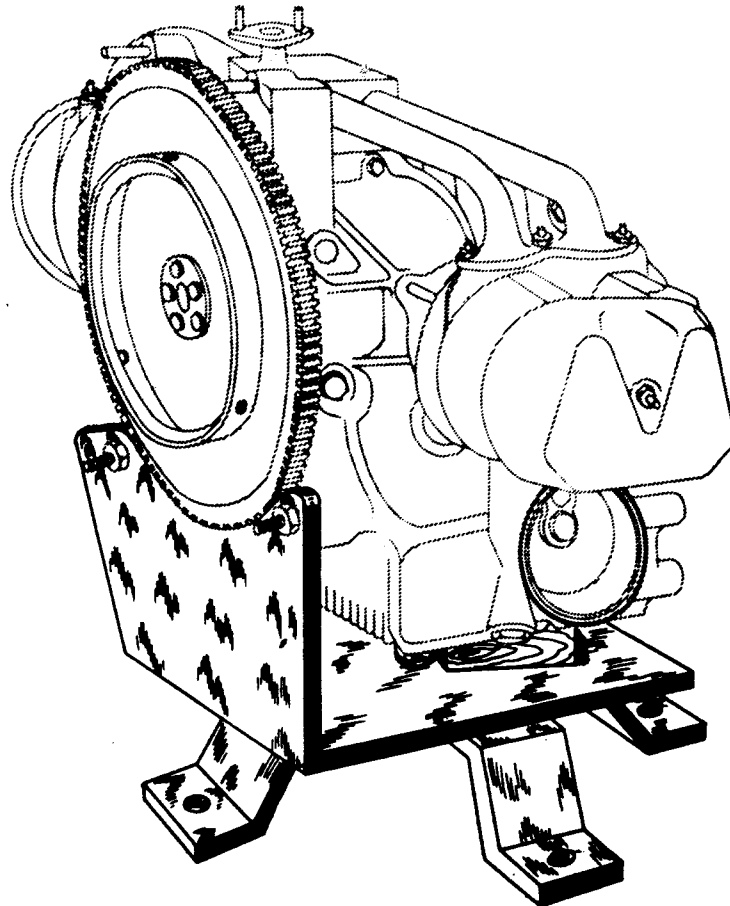

Fig. 2



CALIBRATION OF SPRINGS

1ST - CHECKING THE FREE LENGTH OF A SPRING:

PLACE THE SPRING TO BE CHECKED (1) IN THE TWO GUIDES (2); BY HAND BRING THE SLIDE (3) INTO CONTACT WITH IT. THE INDEX MARK (4) IS OPPOSITE THE FIGURE ON THE SCALE (5) (LENGTH) SHOWING THE FREE LENGTH OF THE SPRING (1).

2ND - CHECKING THE LENGTH UNDER LOAD:

- a: PLACE THE CALIBRATED SPRING (6) (OR 12 AS THE CASE MAY BE) IN THE TWO HOLES (7) AND BRING THE SLIDE (8) INTO CONTACT WITH IT.
- b: BY THE HAND WHEEL (9) BRING THE SPRING (1) TO BE CHECKED TO THE LENGTH UNDER LOAD SHOWN IN THE TEXT; READ THIS LENGTH OPPOSITE THE INDEX MARK (4) ON THE SCALE OF LENGTH (5)
- c: READ ON THE SCALE (10 (LOAD IN KG) OPPOSITE THE INDEX MARK 11 IF USING THE CALIBRATED SPRING (6))
(14 (LOAD IN KG) OPPOSITE THE INDEX MARK 13 IF USING THE CALIBRATED SPRING (12))

Fig. 1 - FIXTURE FOR CALIBRATING SPRINGS.

Sold under No. 2420-T

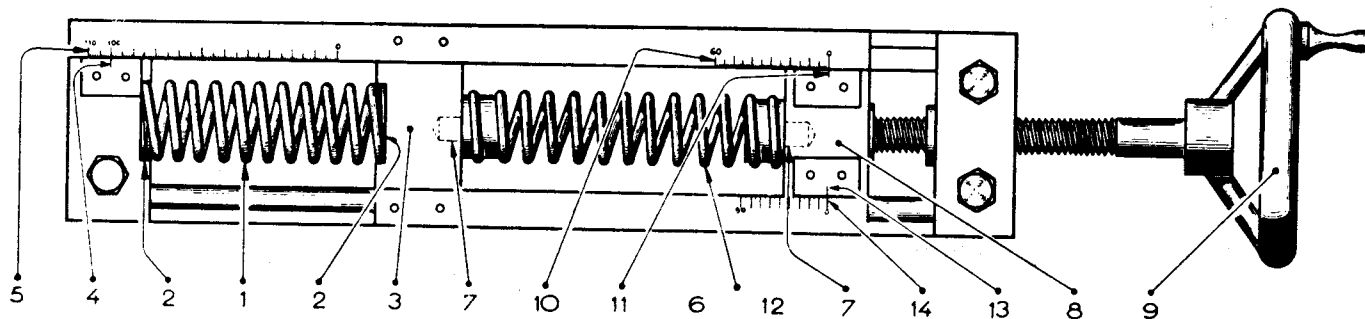

Fig. 2 - CALIBRATED SPRING



SPRING DEFLECTING 1mm. per kg.

Sold under No. 2421-T

This spring is painted yellow



SPRING DEFLECTING 2mm. per kg.

Sold under No. 2422-T

This spring is painted red.

OIL CIRCULATION

Fig. 1 - OIL PUMP

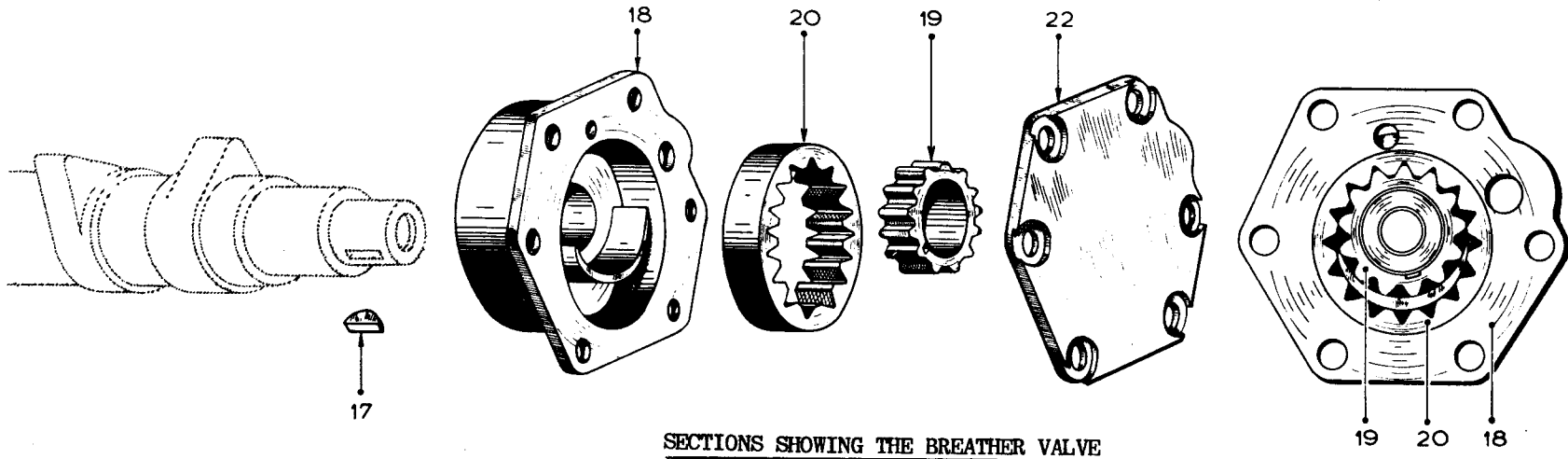

SECTIONS SHOWING THE BREATHER VALVE

Fig. 2

METAL VALVE

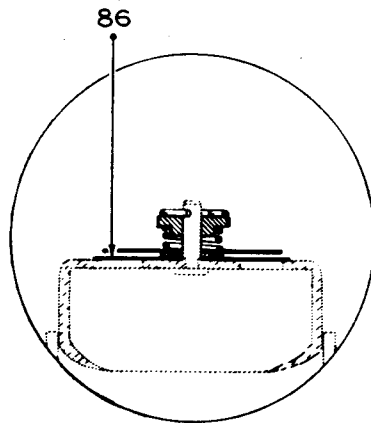

Fig. 3

RUBBER VALVES

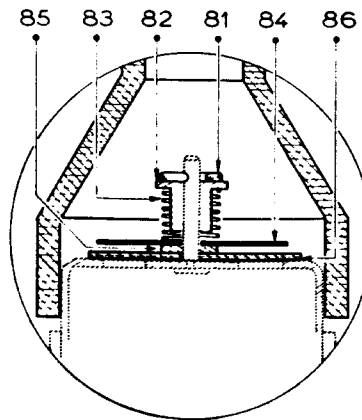
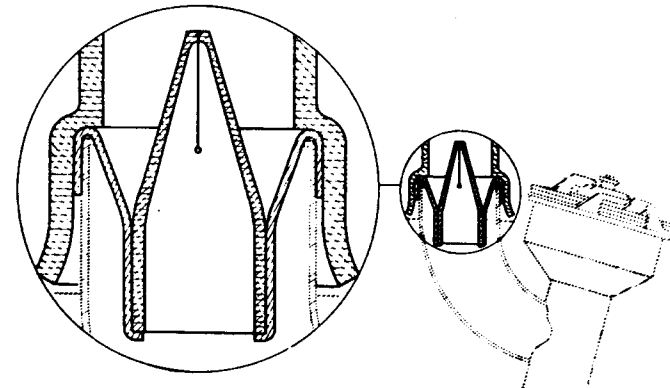

Fig. 4



ENGINE

VARIOUS TOOLS

Fig. 1 - SPARKING PLUG SPANNER

Sold under No. 1601-T

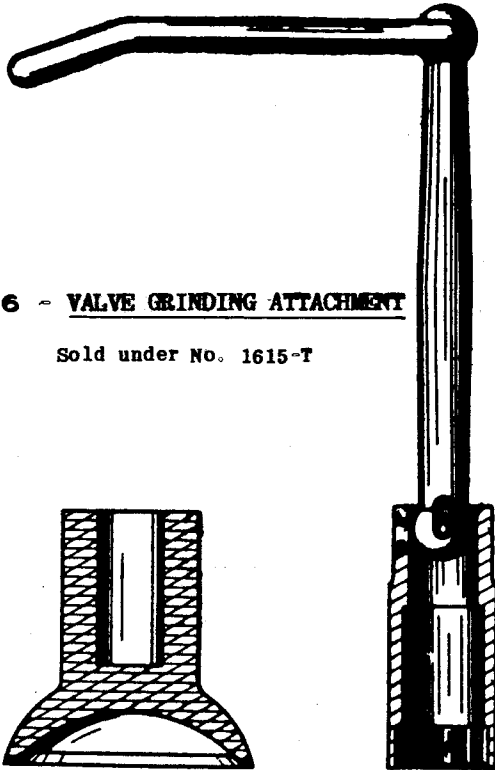

Fig. 6 - VALVE GRINDING ATTACHMENT

Sold under No. 1615-T

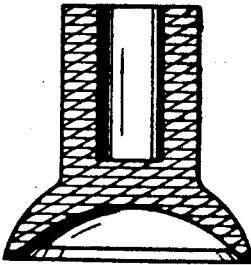

Fig. 2 - STUD DRIVER AND EXTRACTOR

Sold under No. 2410-T

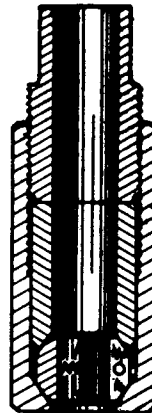
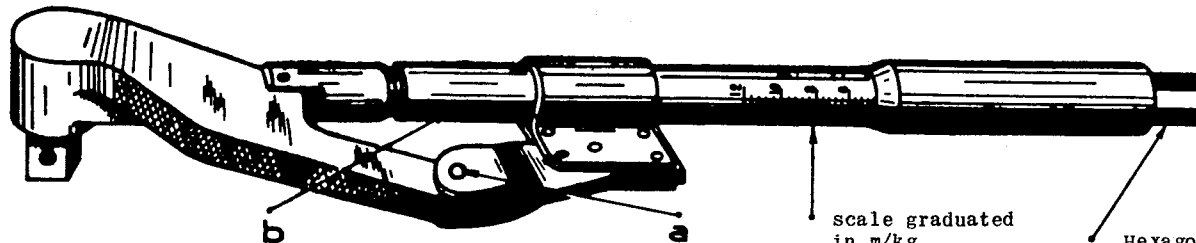

Fig. 5 - TORSION SPANNER

Sold under No. 2470-T

THIS SPANNER IS GRADUATED IN M/KG. AND USES SOCKETS WITH A SQUARE OF 12.7MM. (SOLD UNDER NO. 2465-T.) WHEN THE TORSION LOAD REACHES THE FIGURE SHOWN ON THE SCALE THE LINKAGE "a" BENDS, INDICATING THAT THE TIGHTENING MUST STOP. THE LINKAGE "a" SHOULD NEVER COME UP AGAINST THE BODY OF THE SPANNER AT "b".



scale graduated in m/kg.

Hexagon for adjustment

Fig. 3 - DIAL GAUGE

Sold under No. 2437-T

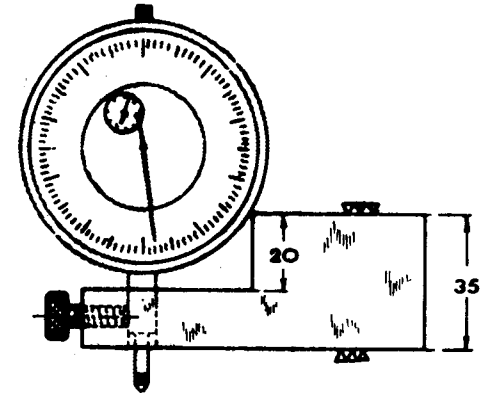
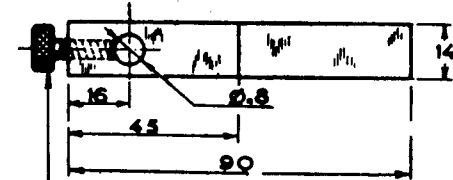

Fig. 4 - DIAL GAUGE BRACKET

Sold under No. 1754-VA



Screw 5x0.90, length under head 16
Knurled head 12mm. dia.

VARIOUS VIEWS

Fig. 1 - OUTSIDE VIEW

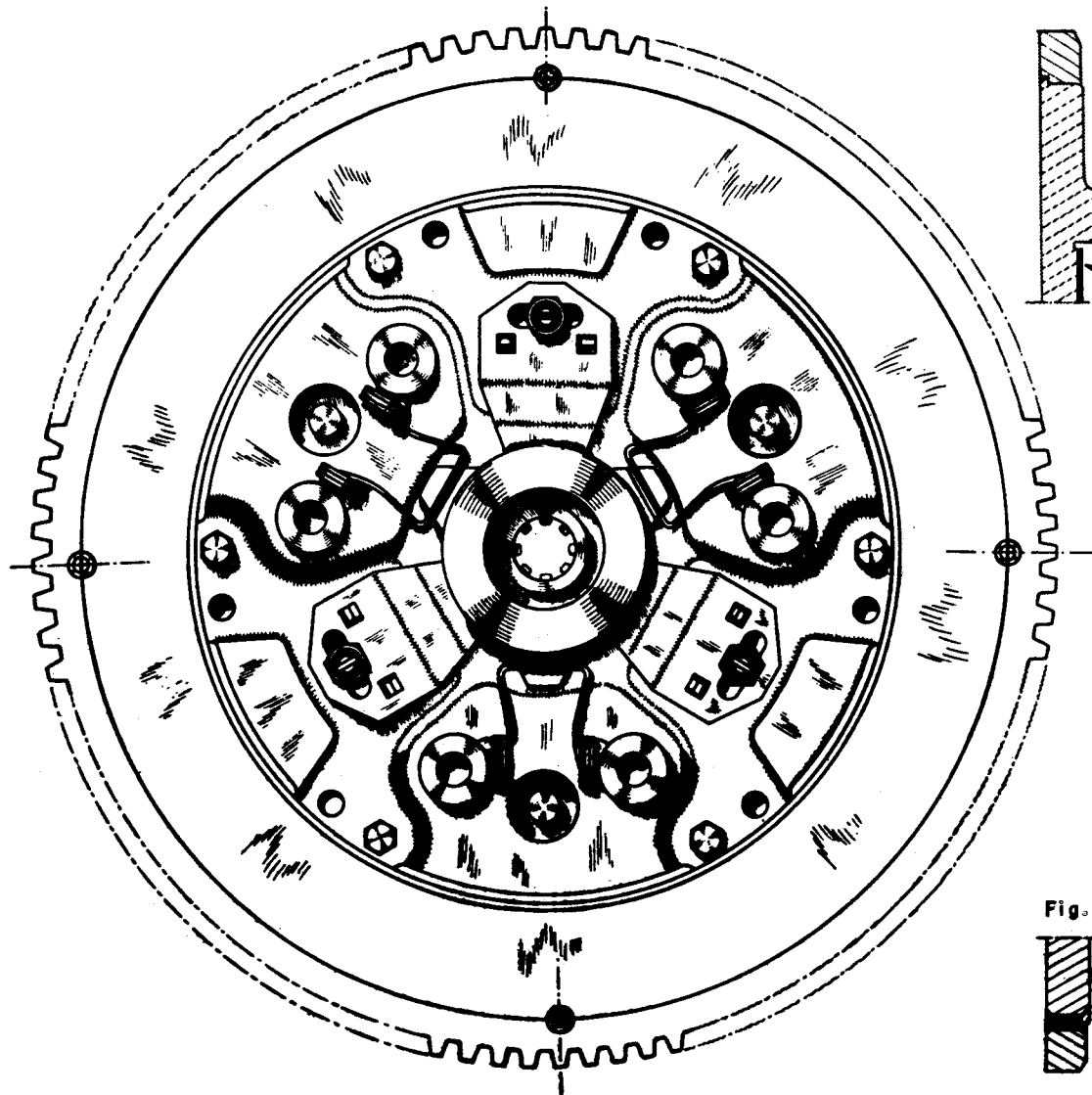

Fig. 2

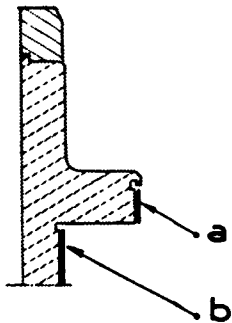

Fig. 3 - SECTION

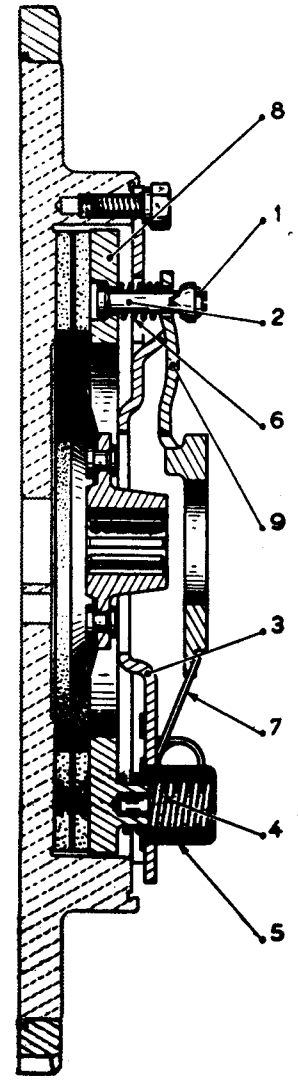
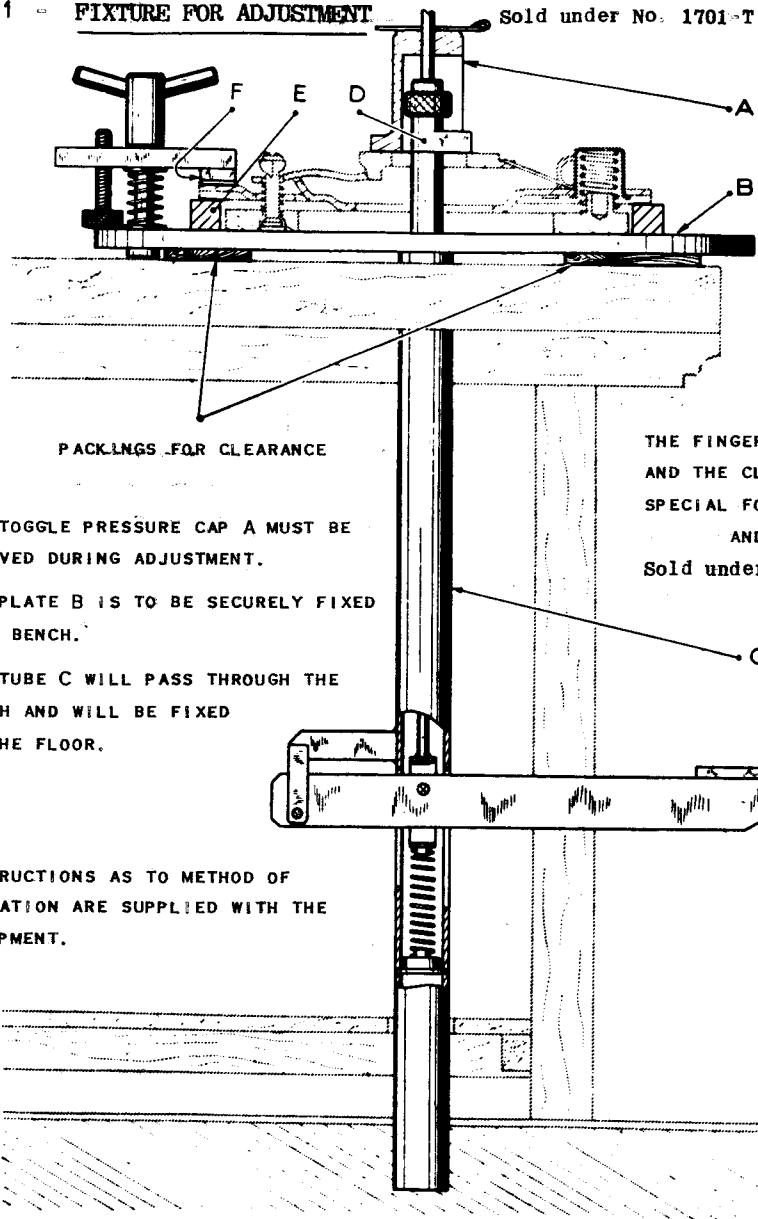

Fig. 4



ADJUSTMENT OF THE CLUTCH

Fig. 1 - FIXTURE FOR ADJUSTMENT

THE FINGER D, THE RING E AND THE CLAMPS F ARE SPECIAL FOR THE 2 CV AND ARE

Sold under No. 1702-VA

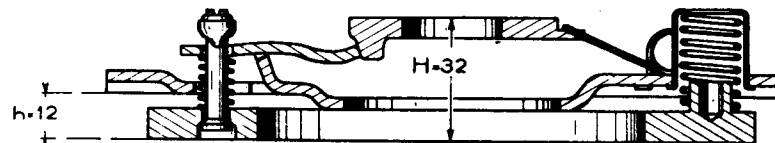
Fig. 2 - CLUTCH MECHANISM IN THE 'ENGAGED' POSITION

THESE DIMENSIONS CAN ONLY BE MEASURED ON A FIXTURE

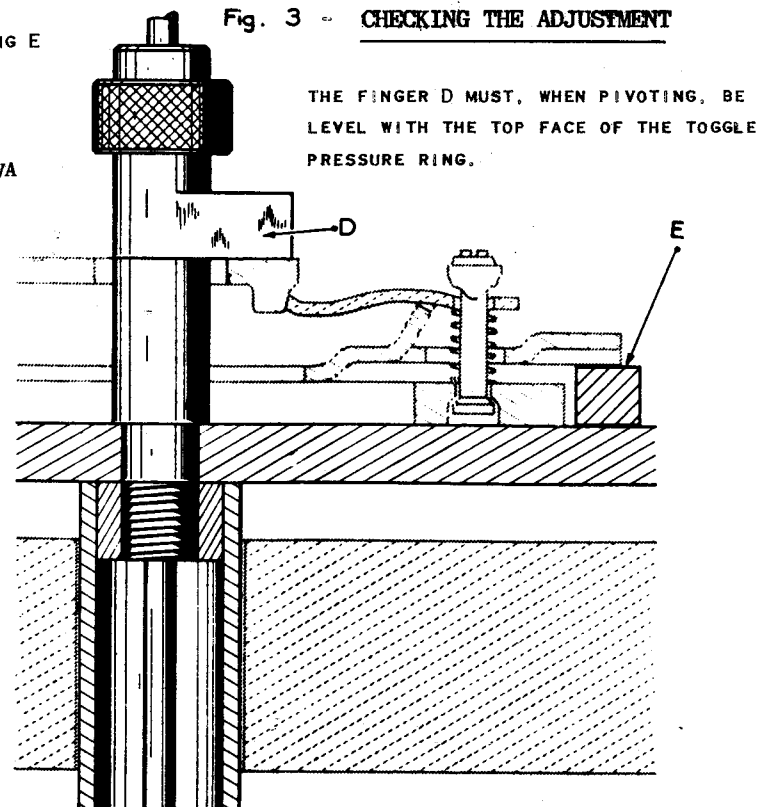
Fig. 3 - CHECKING THE ADJUSTMENT

ADJUSTMENT OF THE CLUTCH

Fig.1 - METHOD OF USE

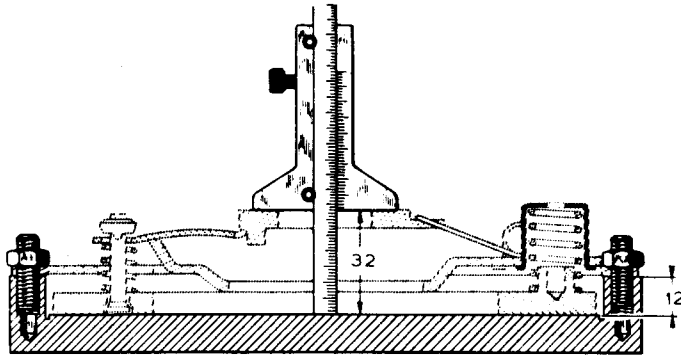

THE DIMENSION 12MM. IS OBTAINED BY THE FIXTURE TO ADJUST THE MECHANISM AFTER HAVING WORKED THE TOGGLES BY MEANS OF A PRESS OR A DRILLING MACHINE, CHECK THE DIMENSION 32 WITH A DEPTH GAUGE. LOCK THE NUTS.

Fig.2 - SIMPLIFIED FIXTURE

Sold under No. 1703-VA

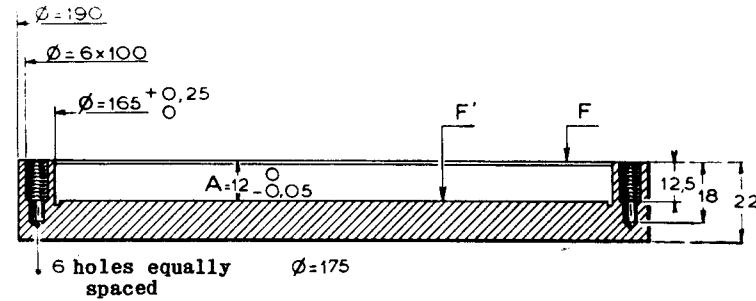

THE CLUTCH IS FIXED ON THE FIXTURE BY 6 STUDS, 6MM. X 100 PITCH 45MM. LONG AND 6 NUTS. THE FACES 'F' AND 'F'' ARE GROUND. THE DIMENSION 'A' BEING VERY IMPORTANT.

Fig.4 - PACKING MR. 3834-10

Not sold

Fig 3 - MANDREL MR.1620-40 FOR CENTERING THE CLUTCH DISC

Not sold

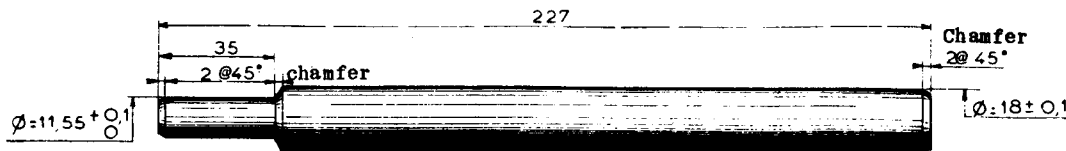

Tube 14.5 I/Dia. x 18mm O/Dia. 50mm. long.

Opened for its whole length 14.5mm. wide.

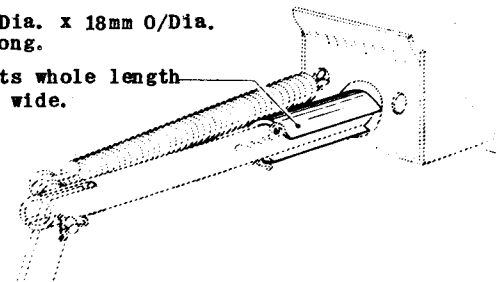

Fig. 1 SECTION

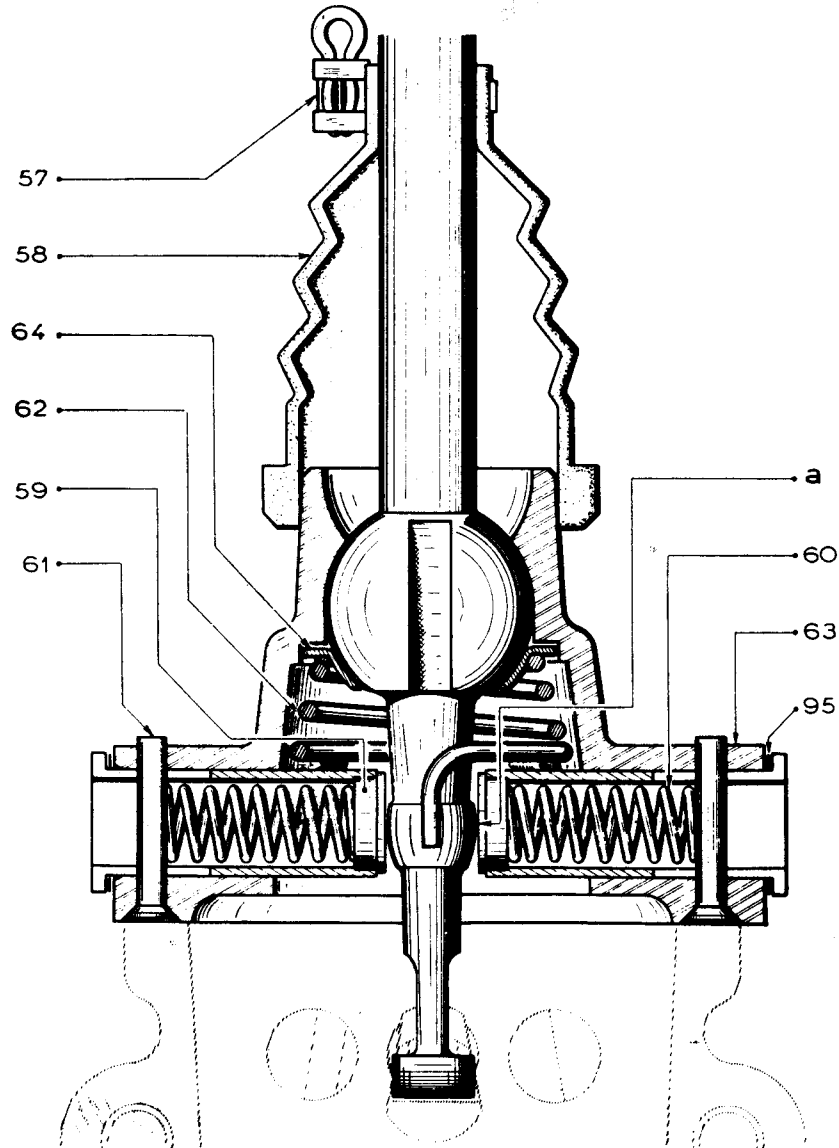
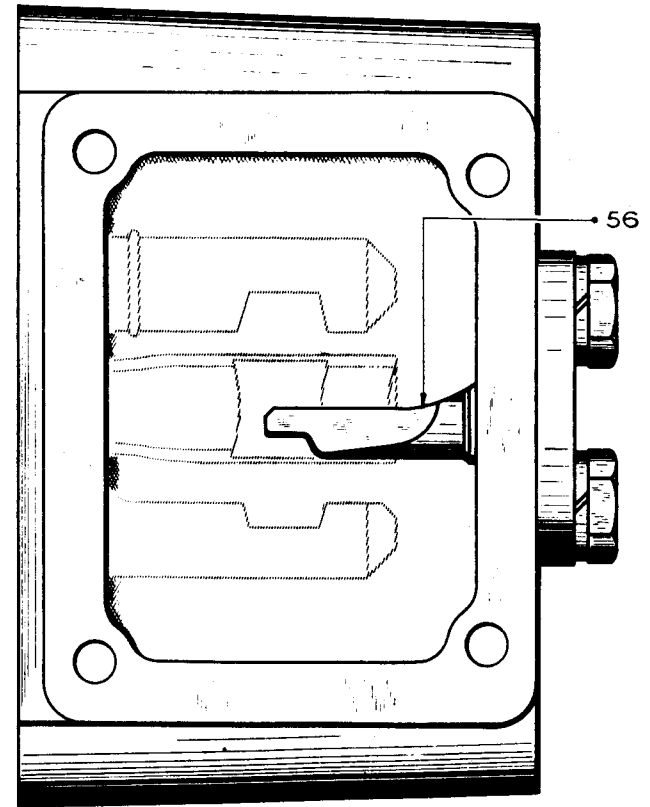
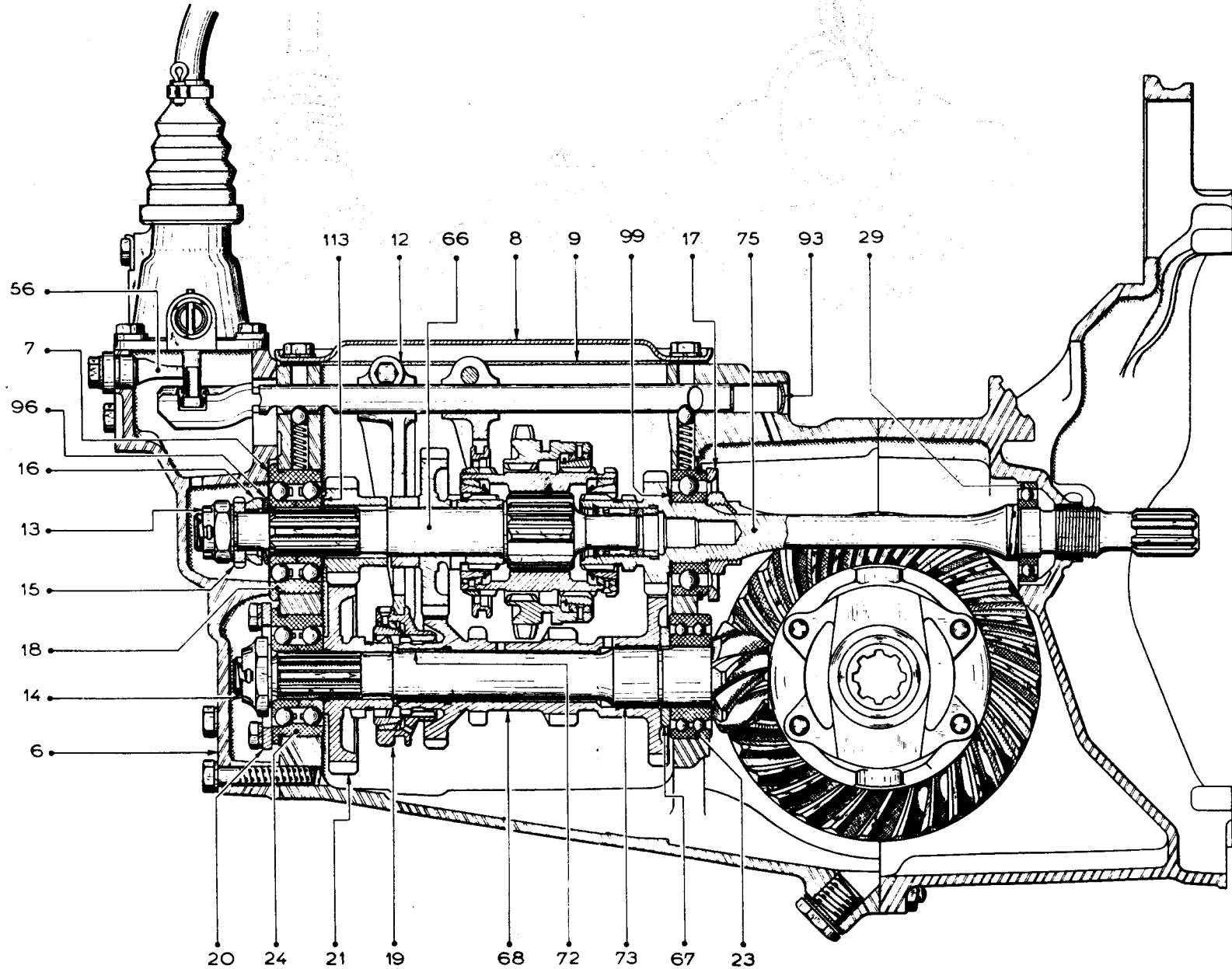

Fig. 2 POSITION OF GUIDE FINGER



LONGITUDINAL SECTION



— GEARBOX —

STAND

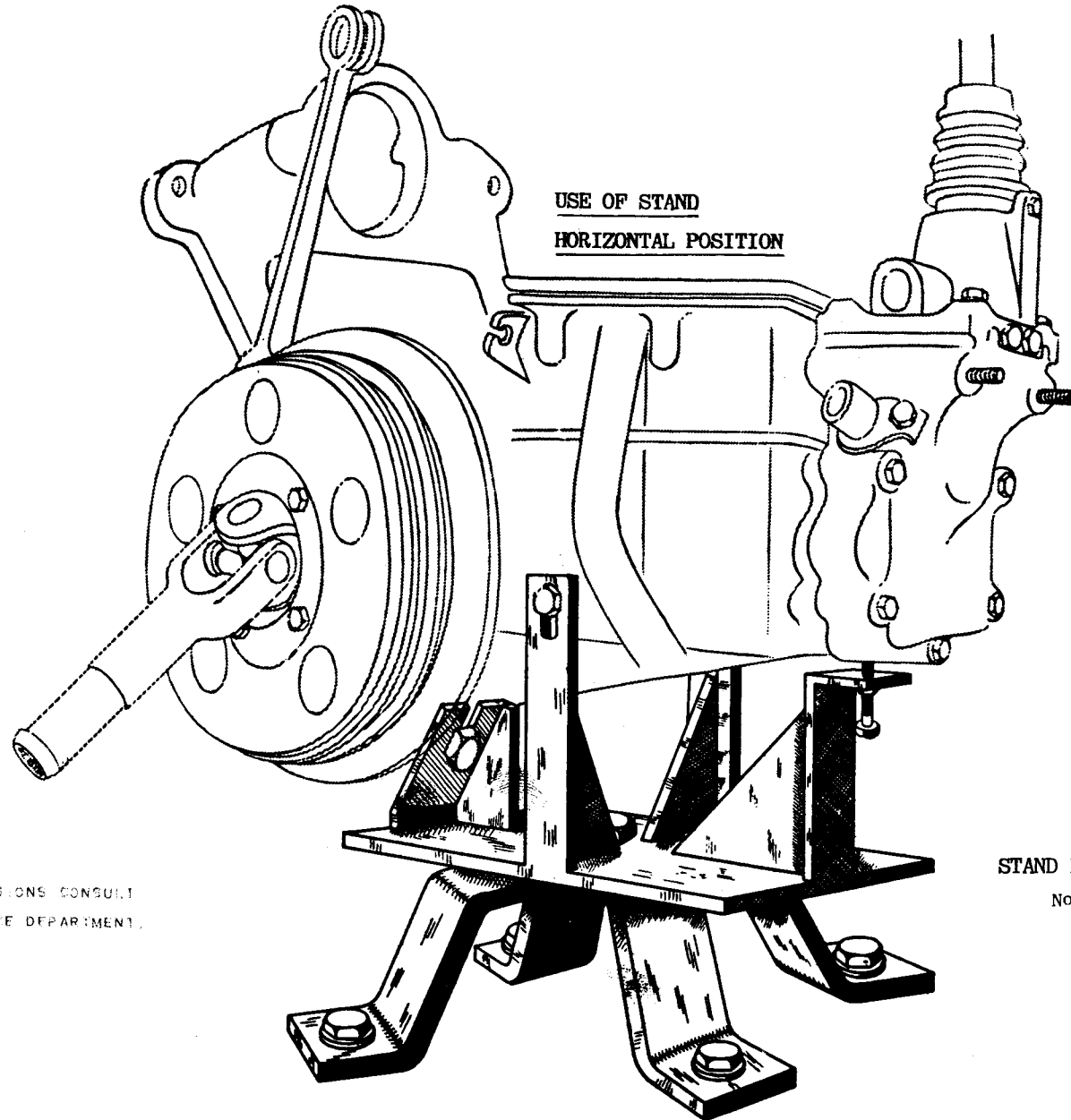

FOR DIMENSIONS CONSULT
OUR SERVICE DEPARTMENT.

STAND MR. 3053 40
Not sold

SECTION OF BRAKE BACKPLATE

ALUMINIUM BACKPLATE

Fig. 1

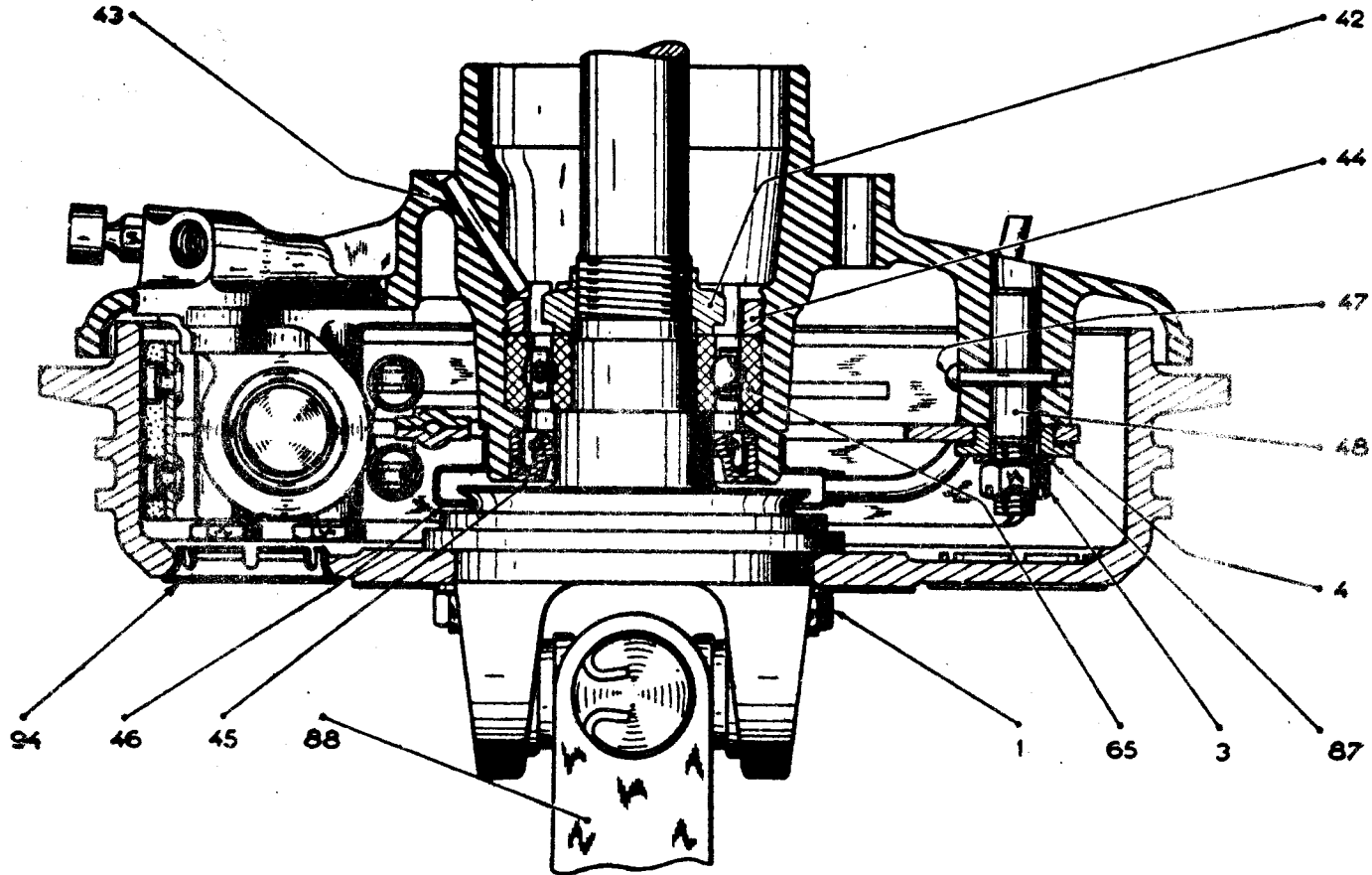
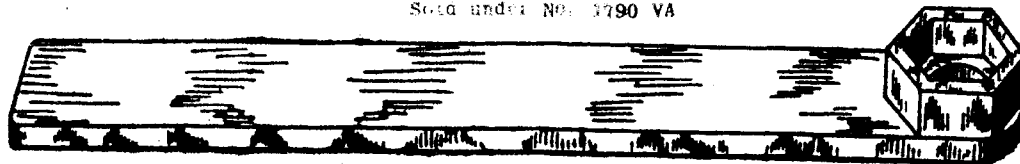

Fig. 2 SPANNER

Sold under No. 1790 VA



— GEARBOX —

— BRAKE BACK PLATE —

— ALUMINIUM —

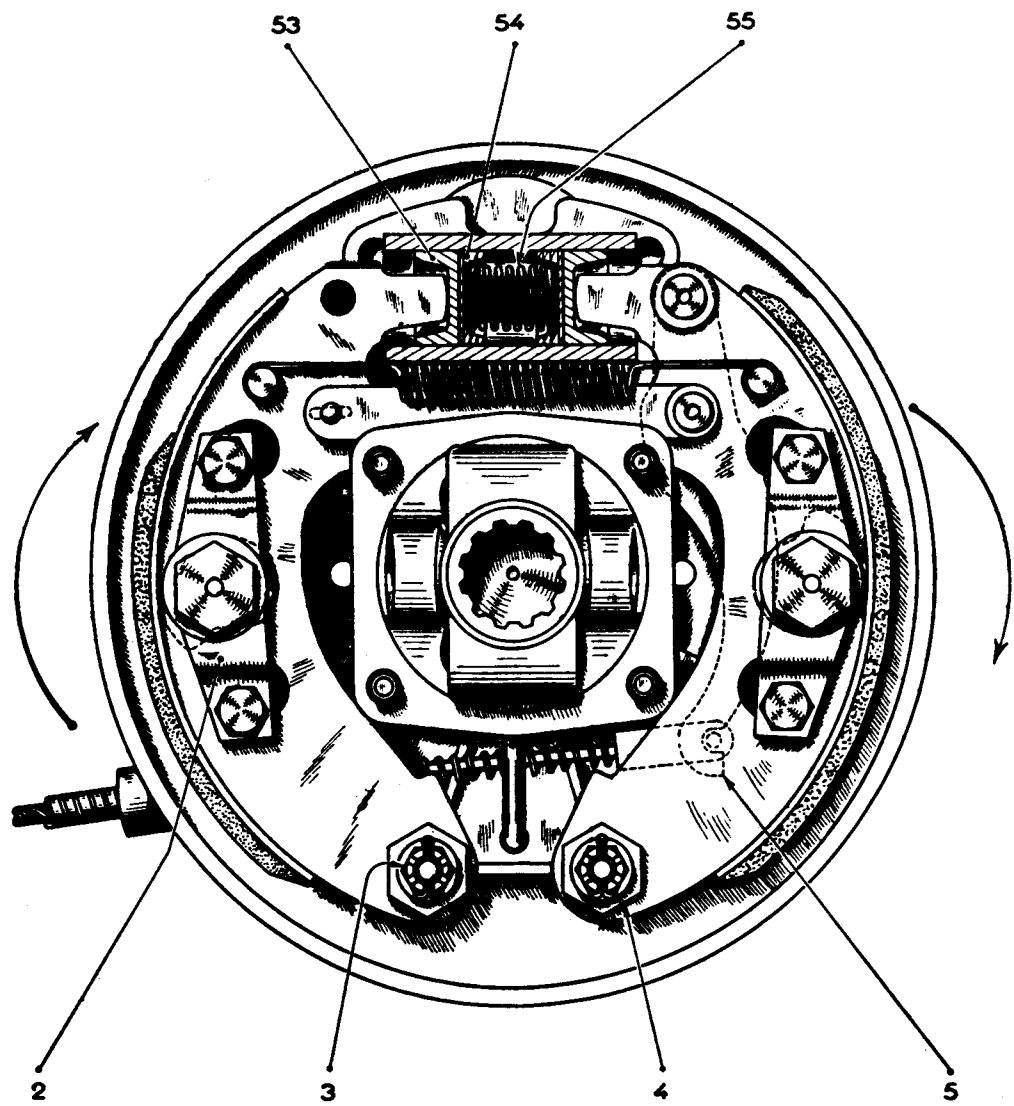

— SECTION OF THE BRAKE BACK PLATE —

— STEEL BACK PLATE —

Fig. 1

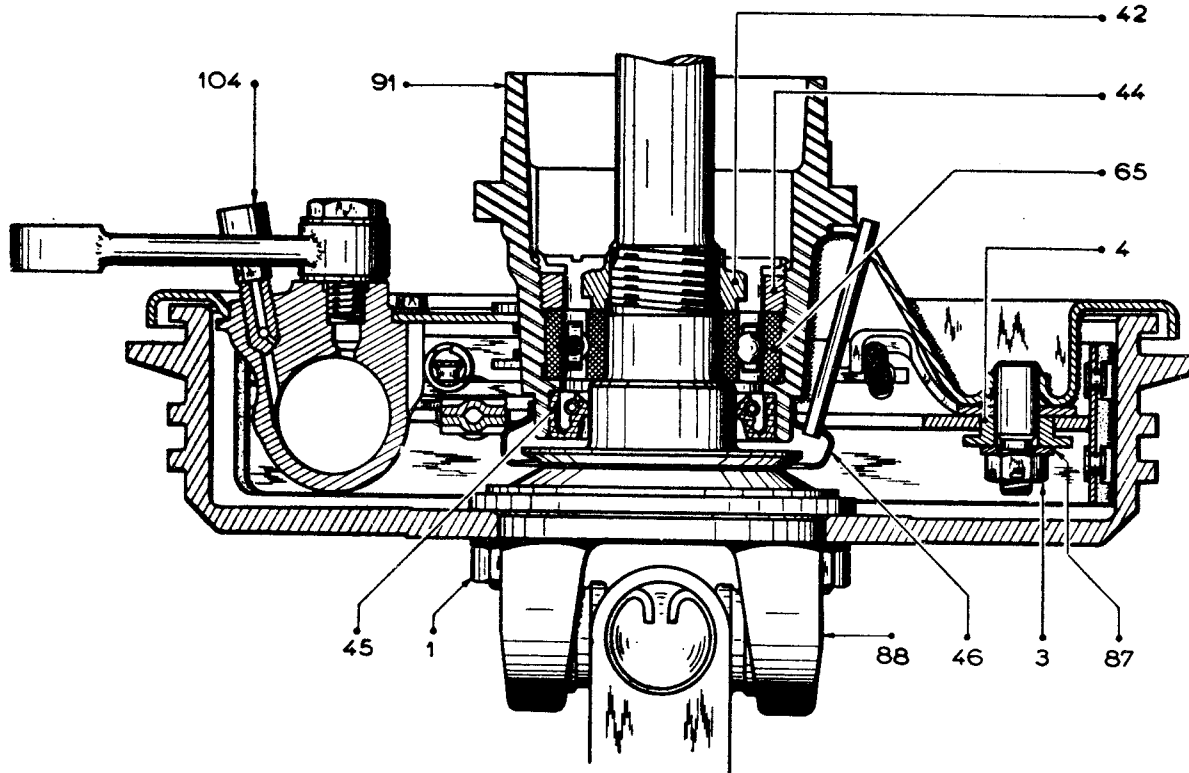
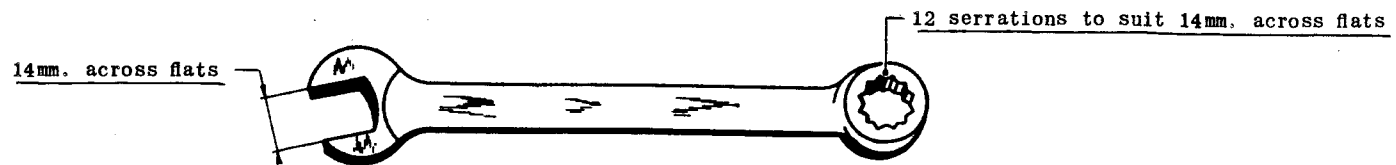

Fig. 2 — SPANNER

Sold under No. 2126-VA



— GEARBOX —

— BRAKE BACK PLATE —

— STEEL BACK PLATE —

SECTION AB

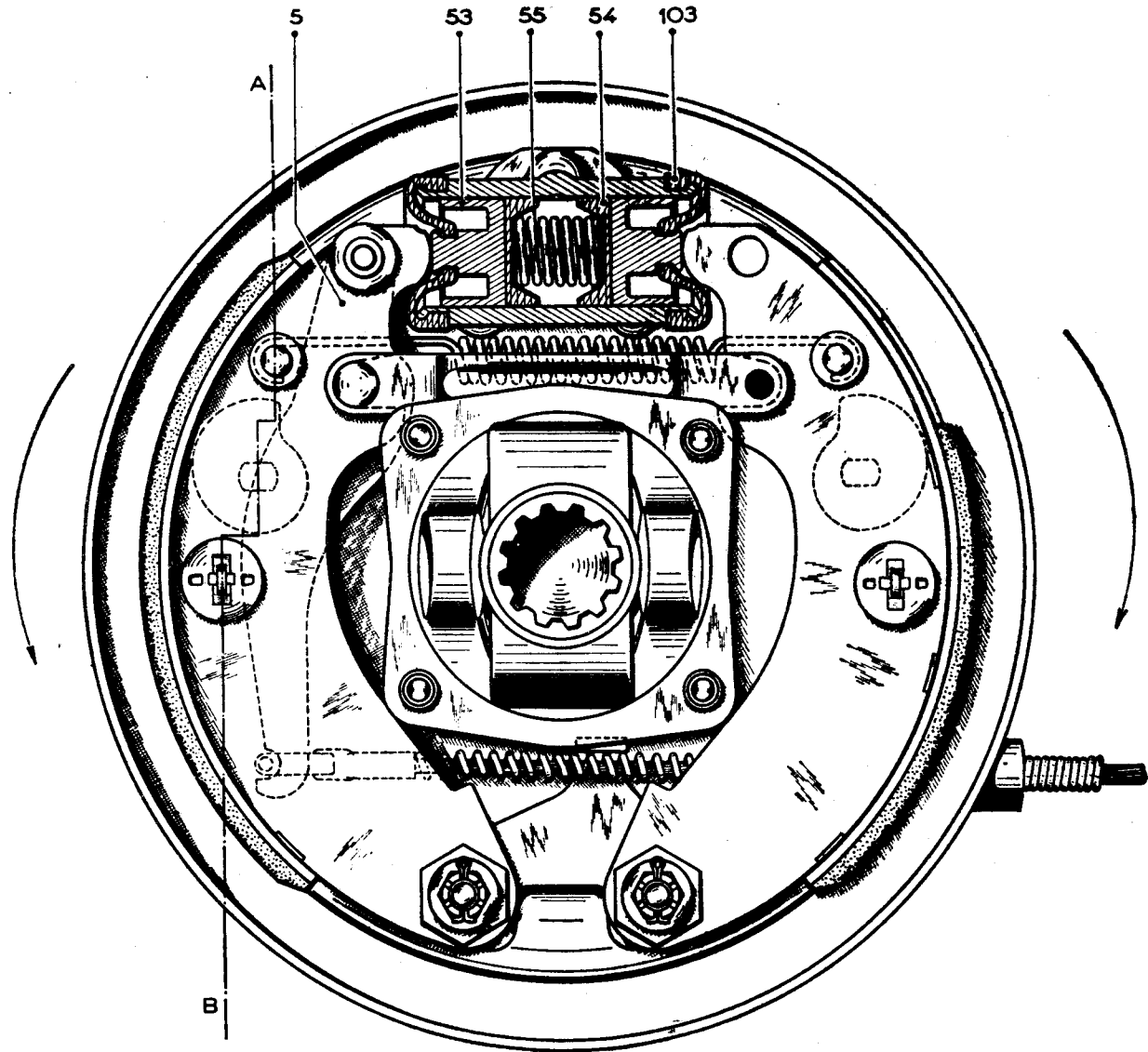
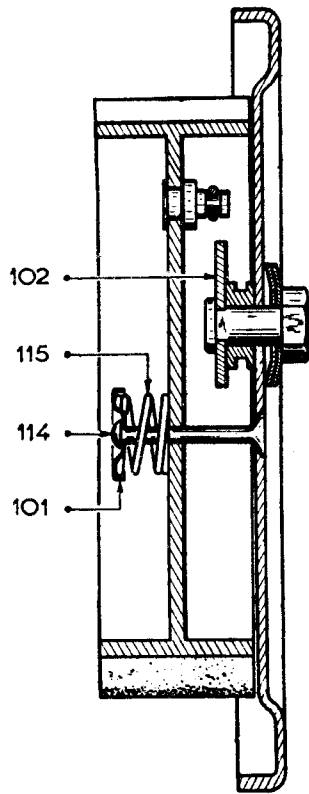

SELECTOR SHAFTS

Fig. 1 - POSITION OF SELECTOR FORKS

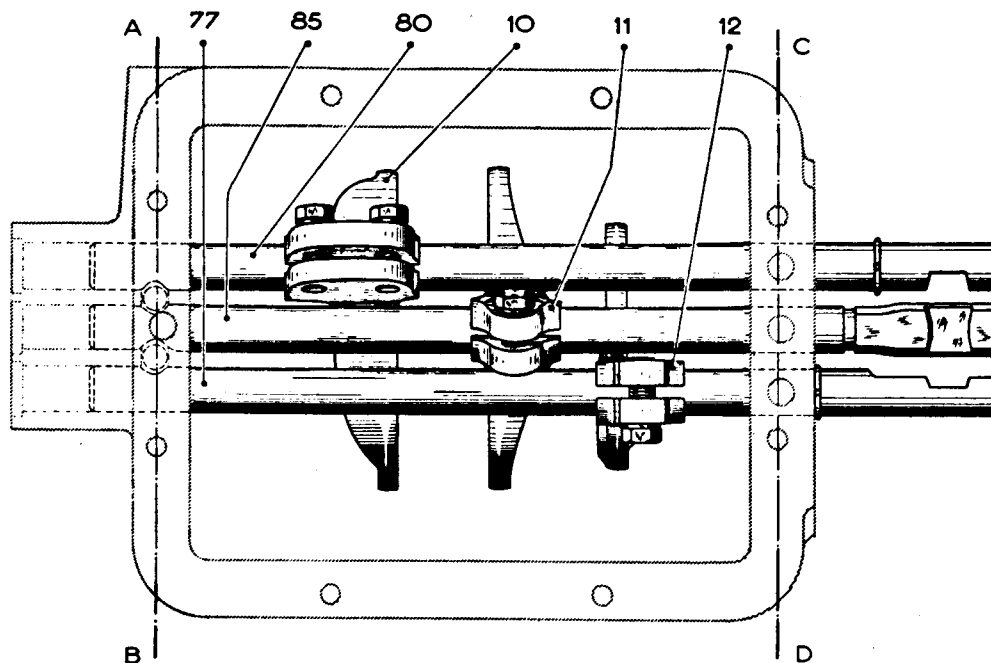

Fig. 2 - LOCKING MECHANISM, FRONT

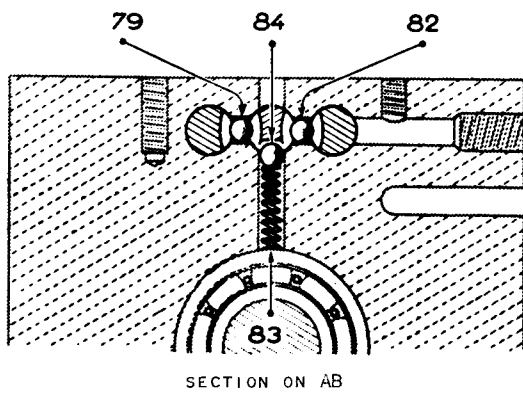
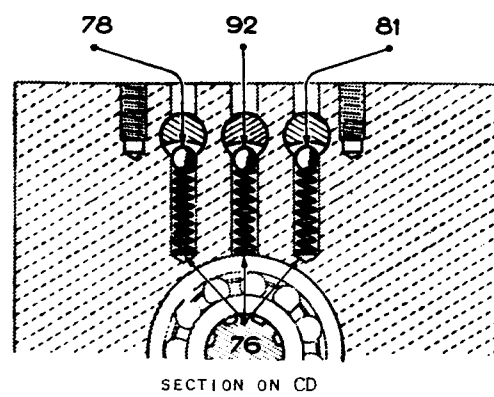

Fig. 3 - LOCKING MECHANISM, REAR



— GEARBOX —

— DISASSEMBLY —

Fig. 1 - EXTRACTOR FOR REVERSE PINION SHAFT

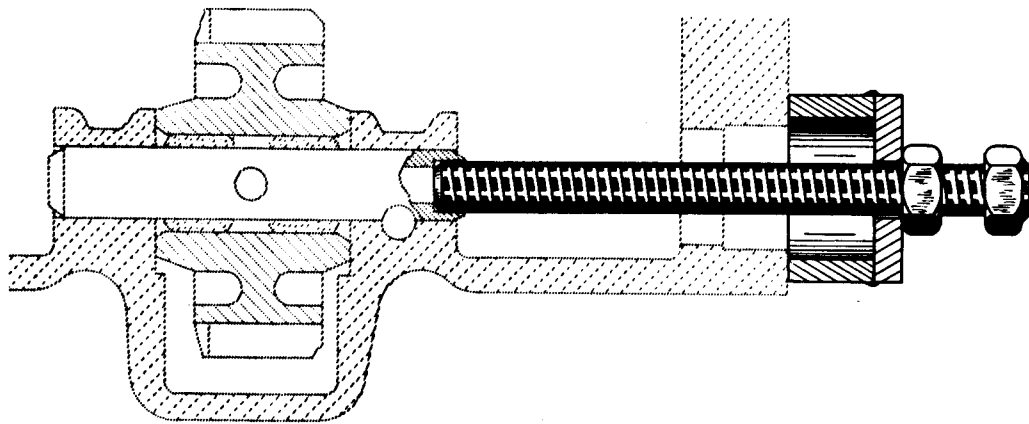

Fig. 2 - REMOVAL OF THE BEARING

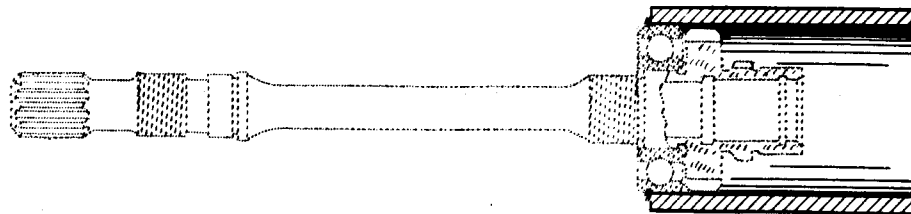

Fig. 3 - EXTRACTOR MR. 3682-30

Not sold

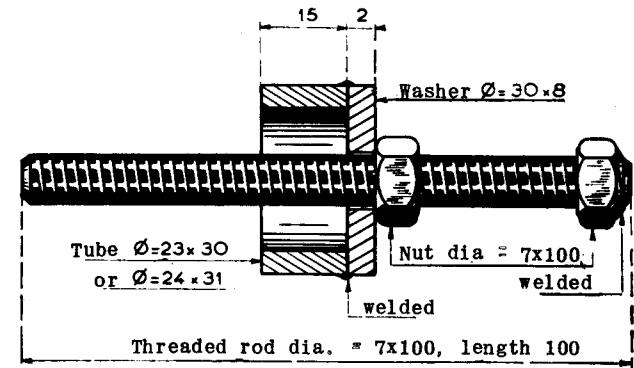
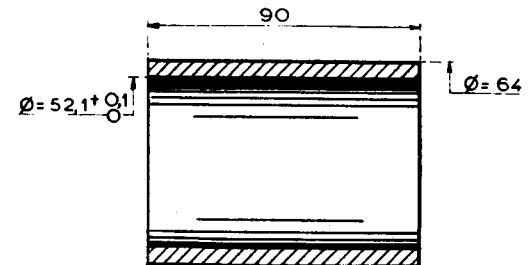

Fig. 4 - RING MR. 3686

Not sold



— GEARBOX —

— SECTIONS —

Fig 1 — BEVEL PINION SHAFT

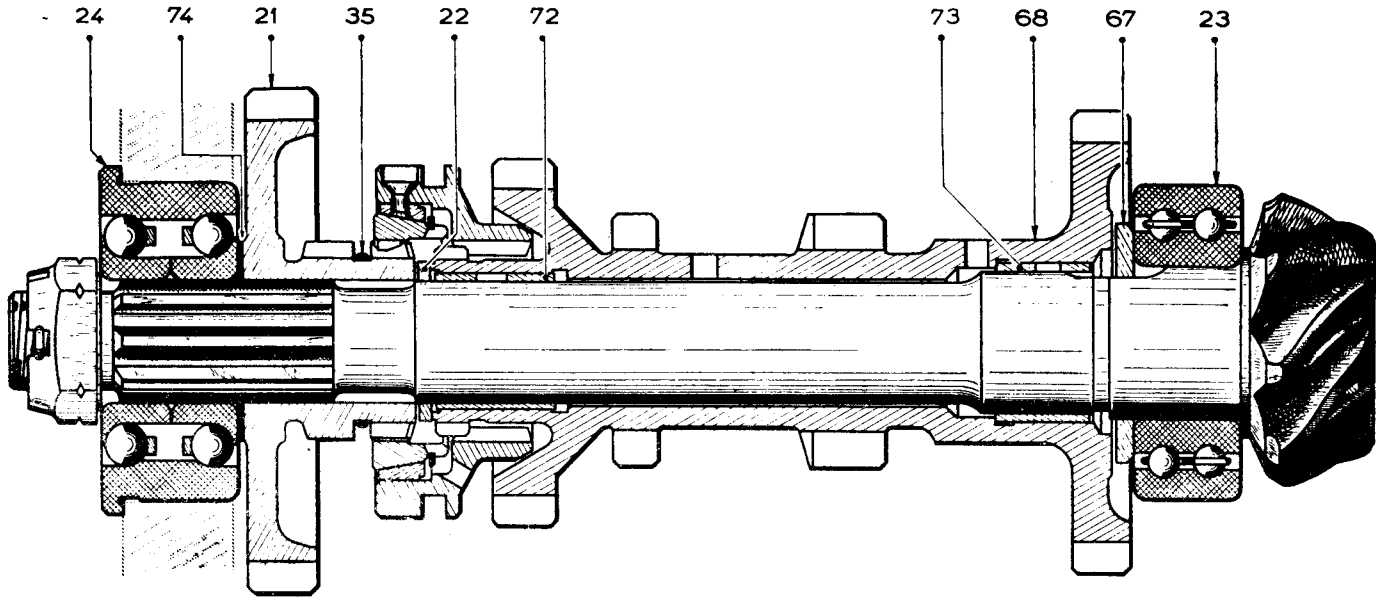

Fig. 2

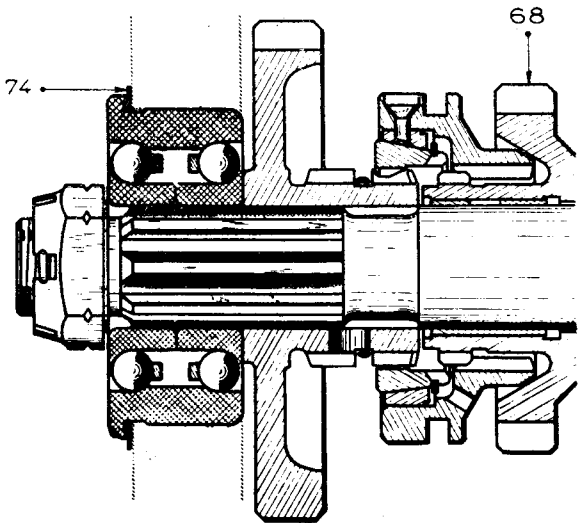

Fig. 3

Fig. 4

POSITION OF THE SYNCHRONISING CIRCLIP

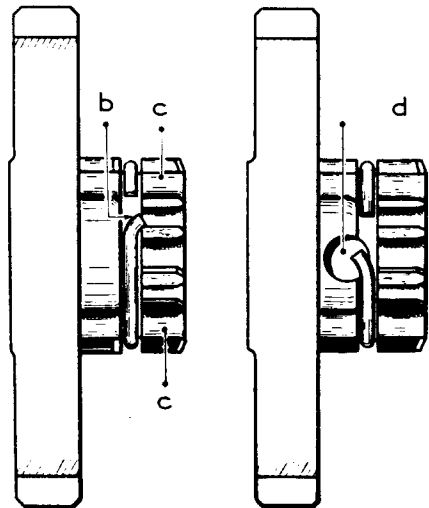
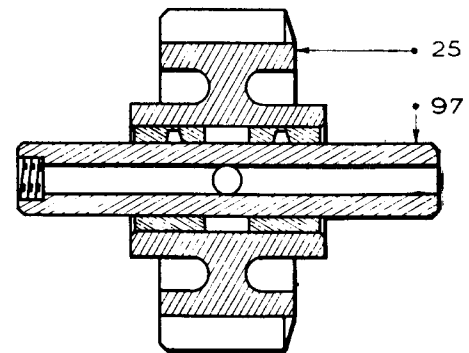

Fig. 5

REVERSE PINION



— GEARBOX —

— SECTIONS —

Fig. 1 — MAIN SHAFT

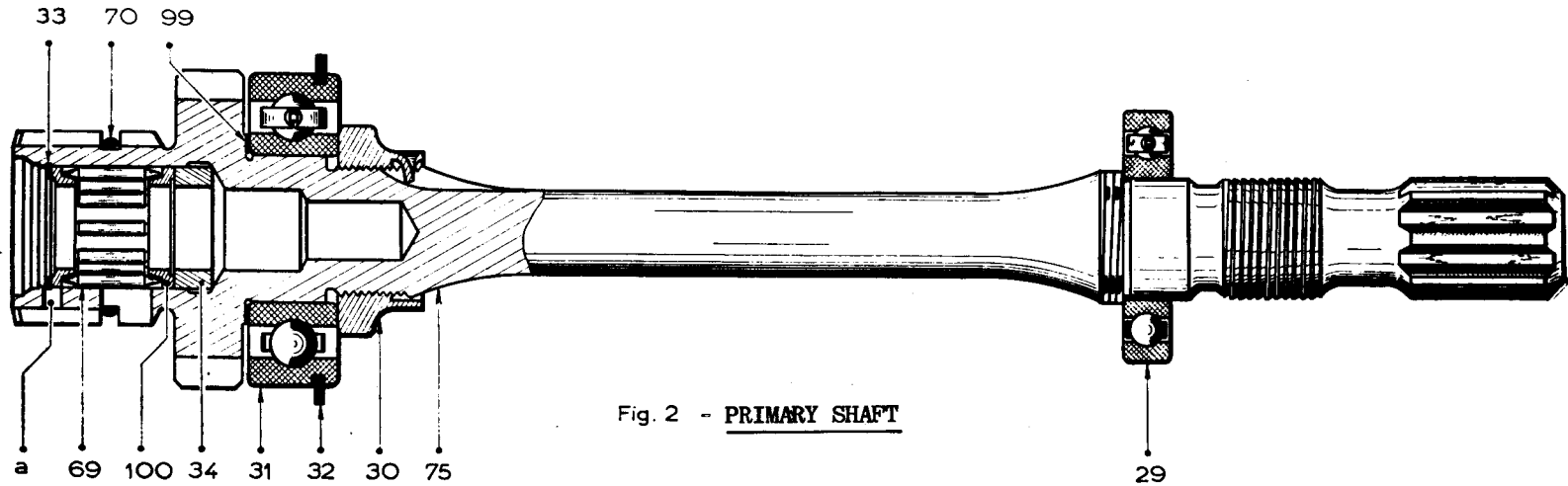
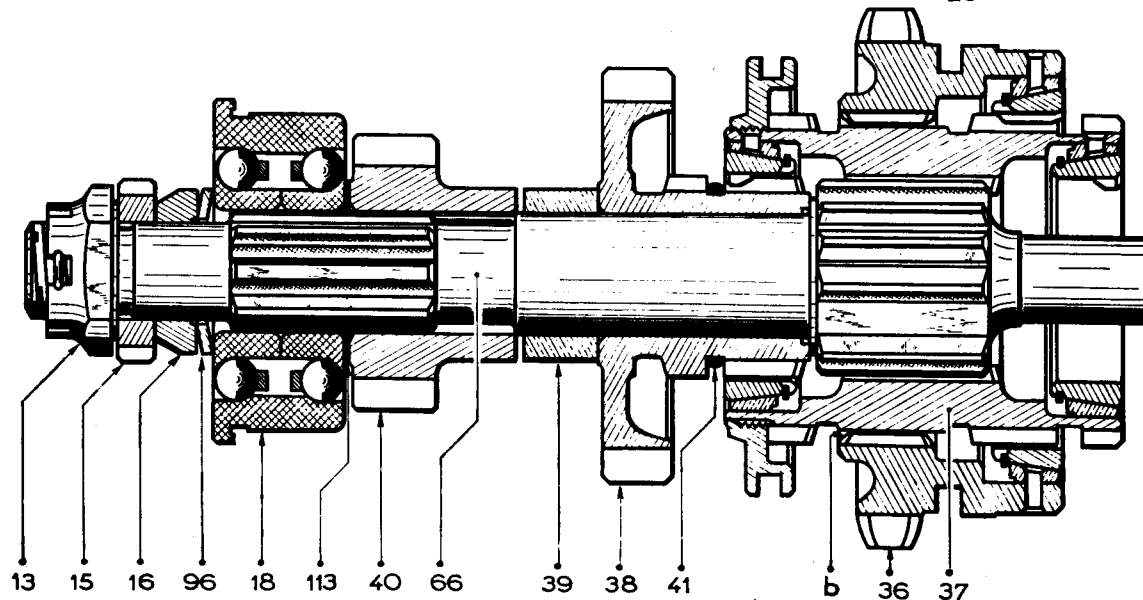
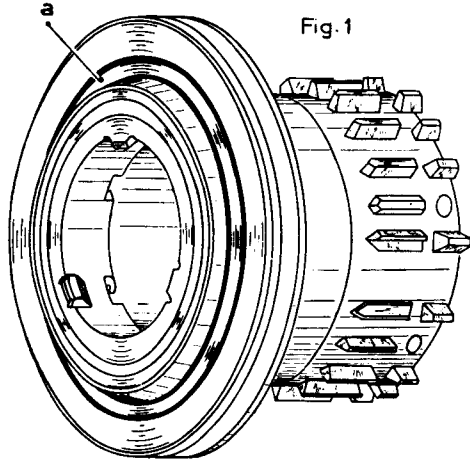

Fig. 2 — PRIMARY SHAFT



— 2nd AND 3rd SPEED SLIDING GEAR AND SPEEDOMETER DRIVE PINION —



ON THE 1ST TYPE SLIDING GEAR
THERE IS A GROOVE AT 'a'

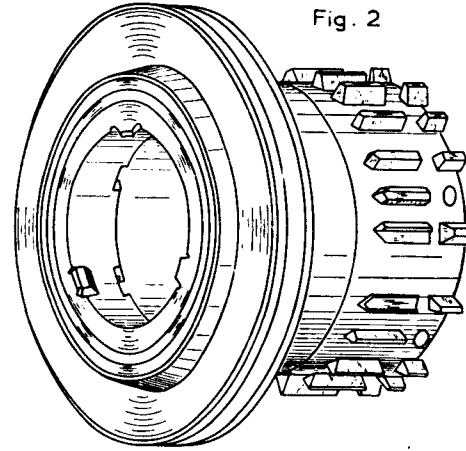

ON THE 2ND TYPE SLIDING GEAR
THERE IS NO GROOVE

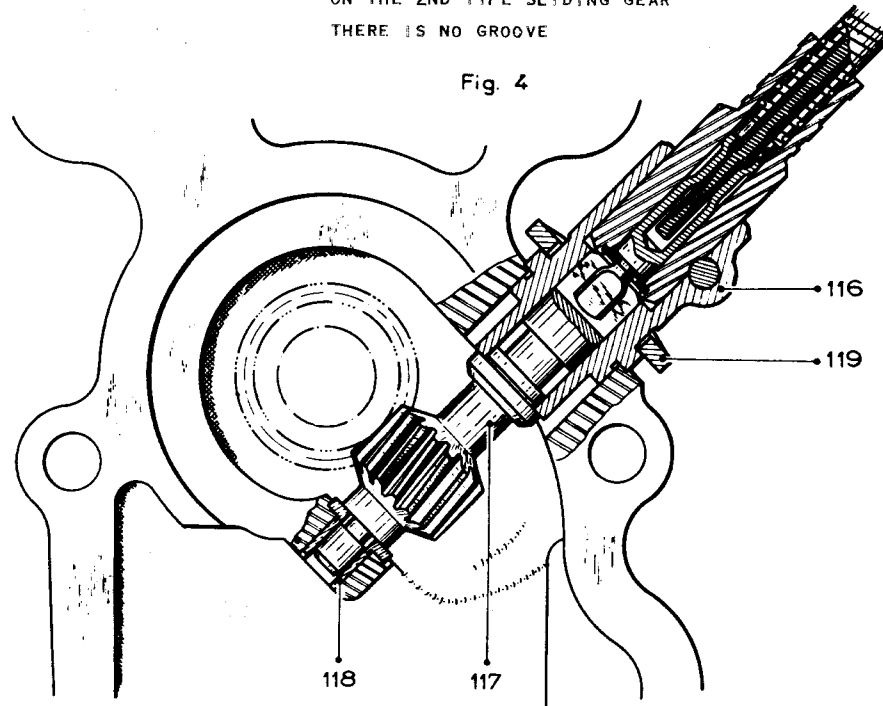
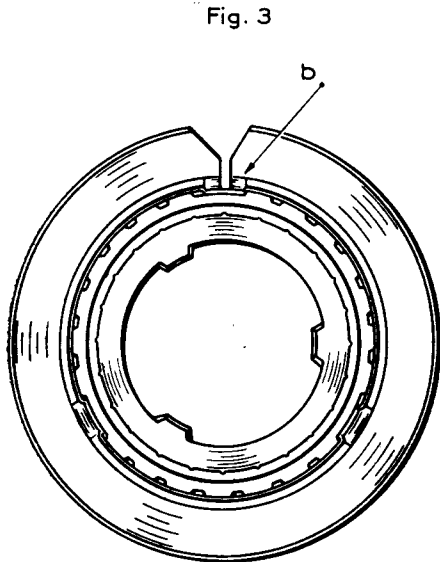

— SECTION OF THE DIFFERENTIAL —

Fig. 1 - VIEW FROM THE FRONT OF THE CAR

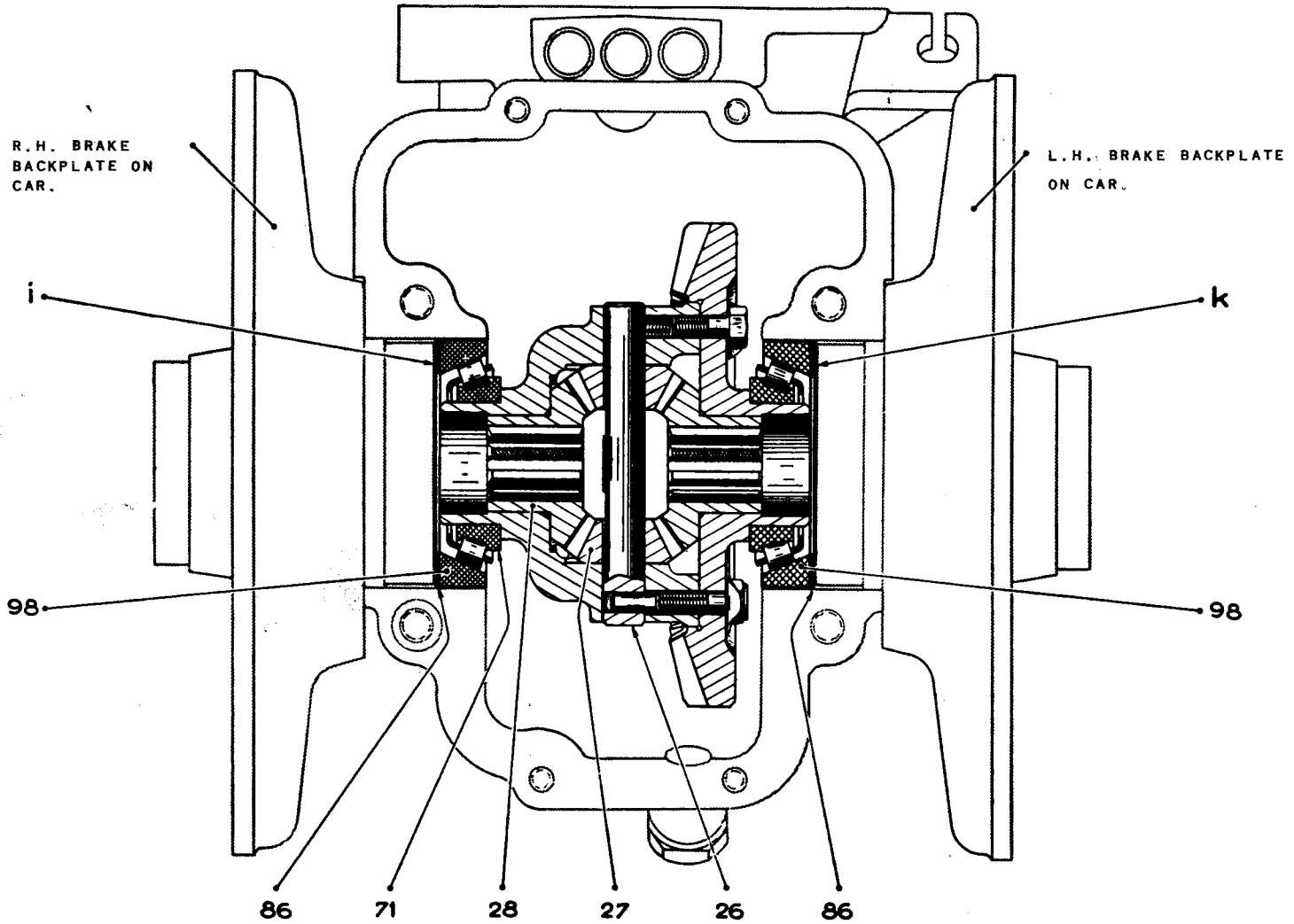

— GEARBOX —

— CLUTCH HOUSING —

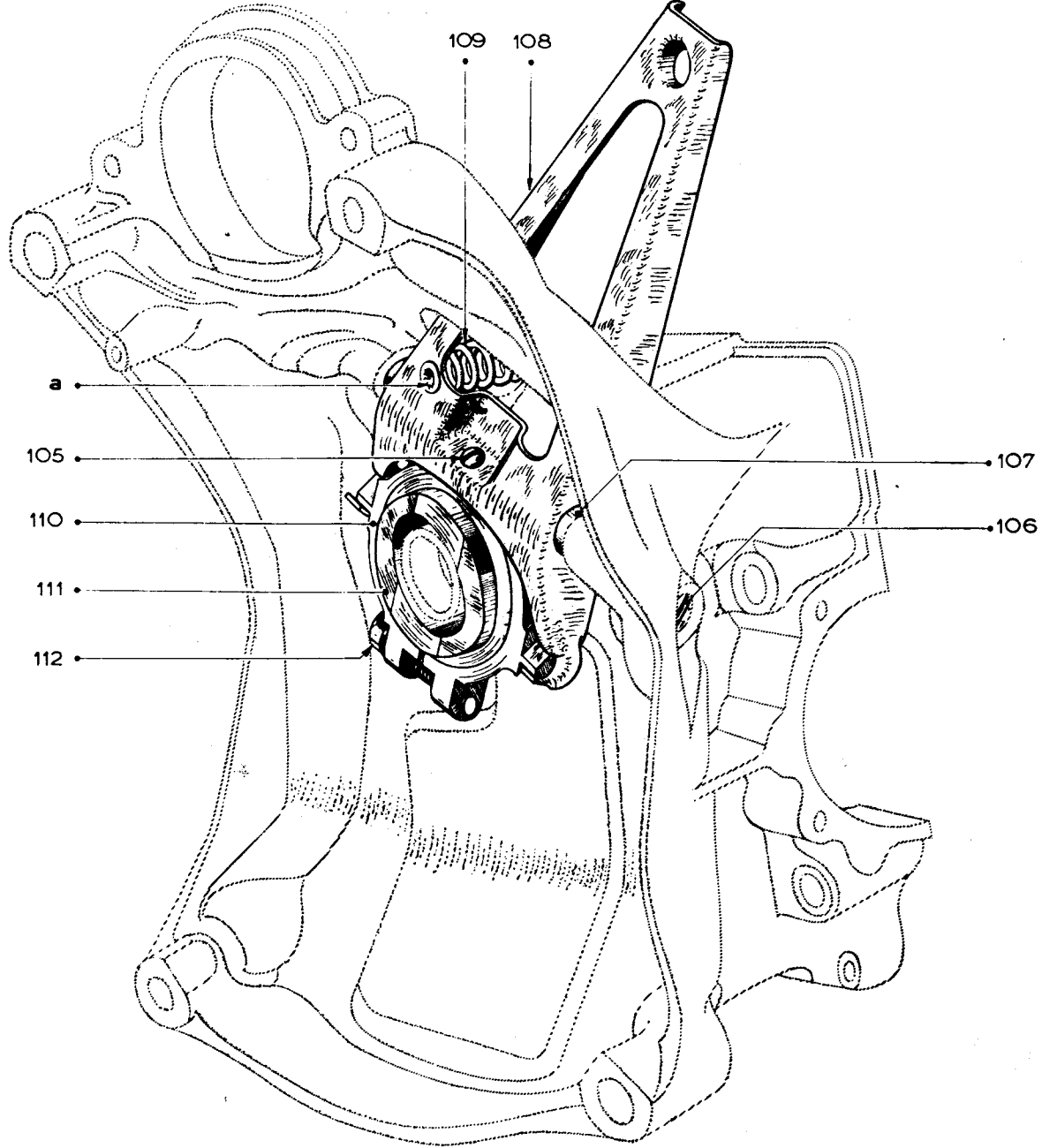

— EXTRACTION OF THE DIFFERENTIAL BEARING —METHOD OF USING THE EXTRACTOREXTRACTOR BODY WITH SCREW

Sold under No. 1750-T

HALF SHELLS WITH RETAINING RING

Sold under No. 1736-T

PRESSURE PAD

Sold under No. 1743-VA

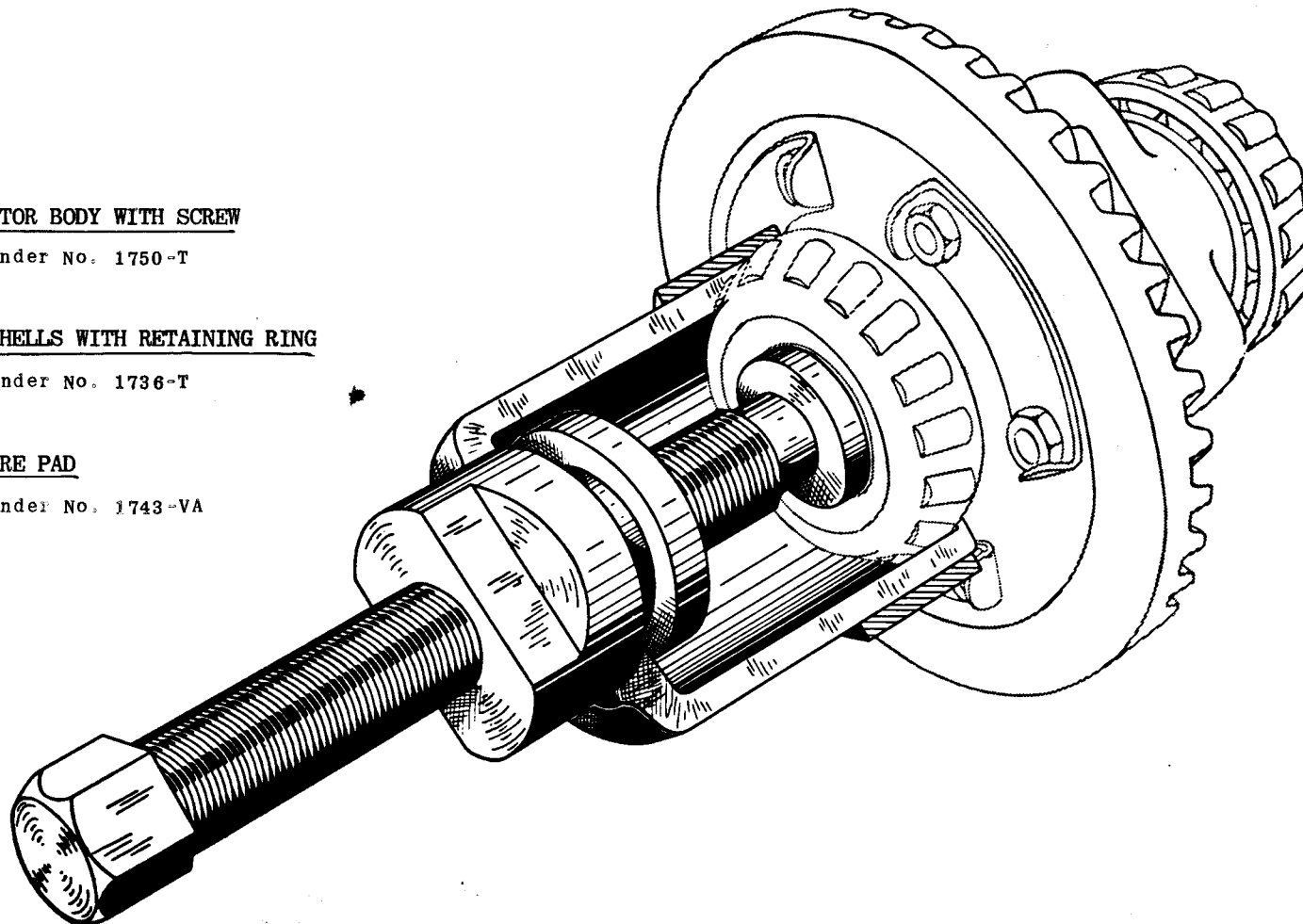

— TIGHTENING THE RING NUT ON THE BRAKE BACKPLATE —

Fig. 1 - SPANNER FOR THE RING NUT ON THE FRONT BRAKE BACKPLATE (Aluminium)

Sold under No. 1925-VA

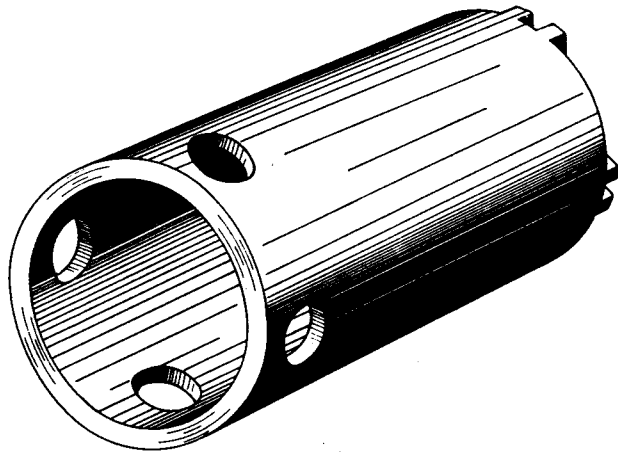
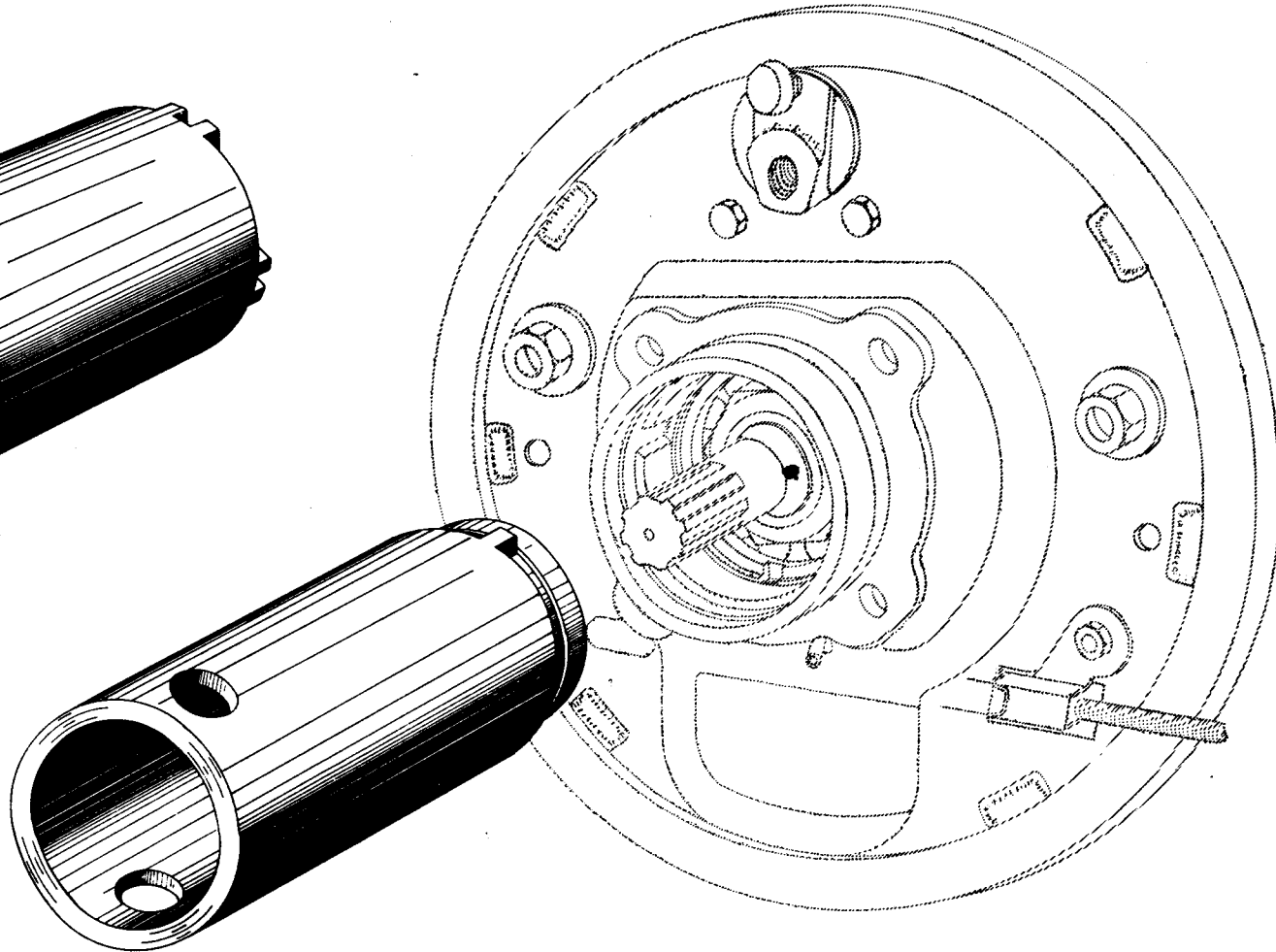
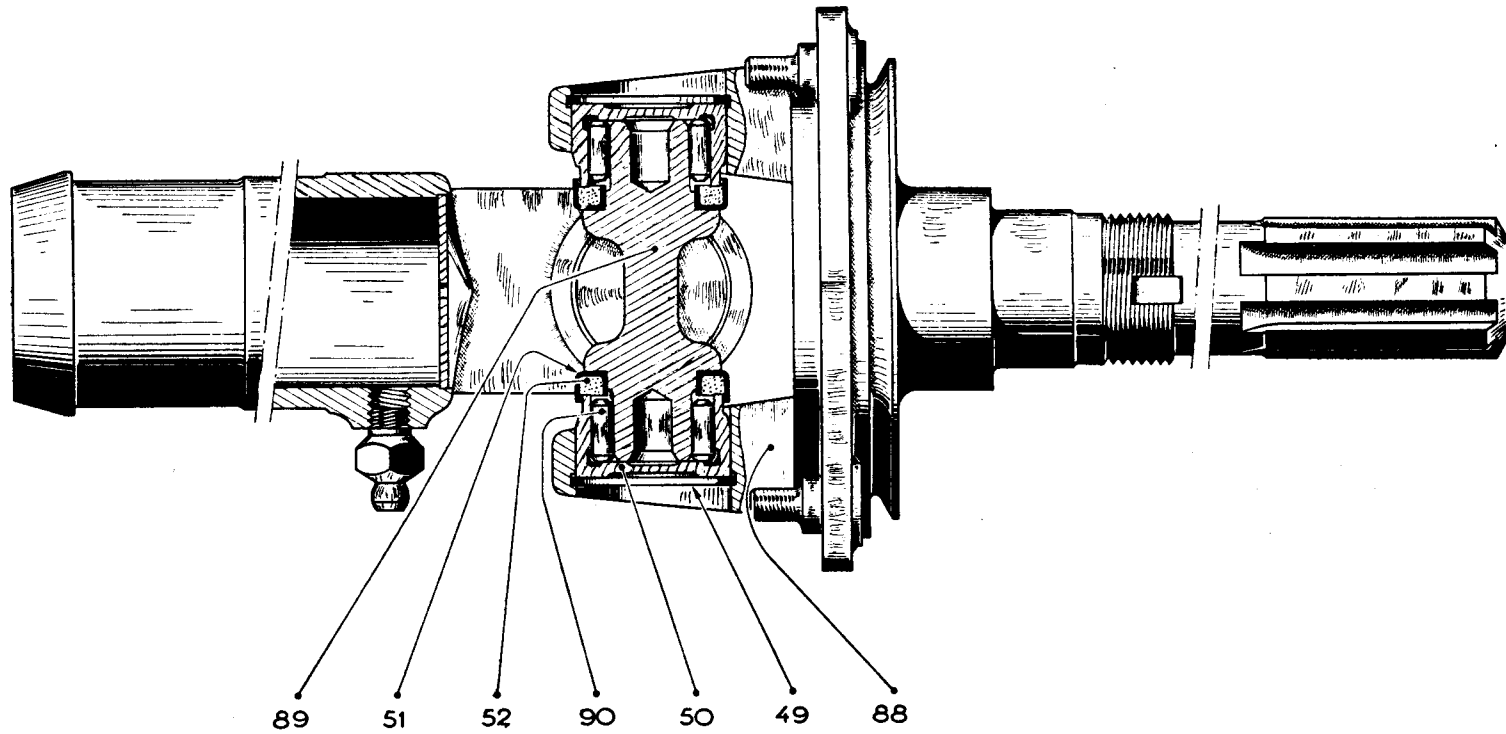

Fig. 2 - SPANNER FOR THE RING NUT ON THE FRONT BRAKE BACKPLATE (Steel)

Sold under No. 1926-VA



— UNIVERSAL JOINT, GEARBOX END —Fig. 1 - SECTION

— ASSEMBLY OF THE BRAKE SHOES —

Fig. 1

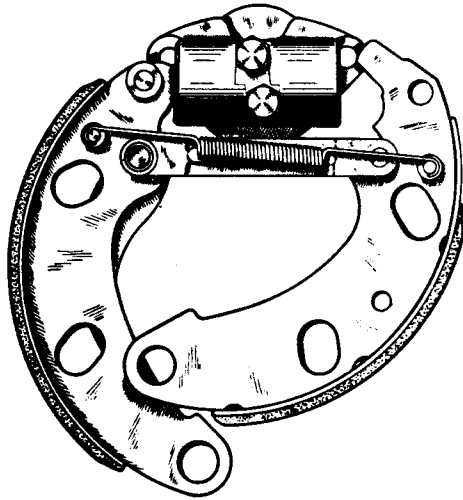
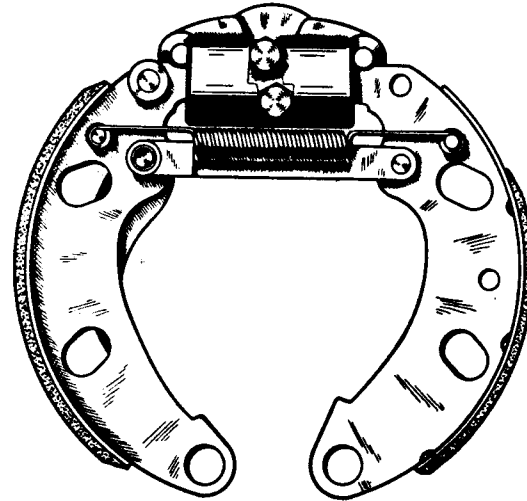

Fig. 2



FITTING THE BEARING

Fig. 1 - USE OF THE TOOLS

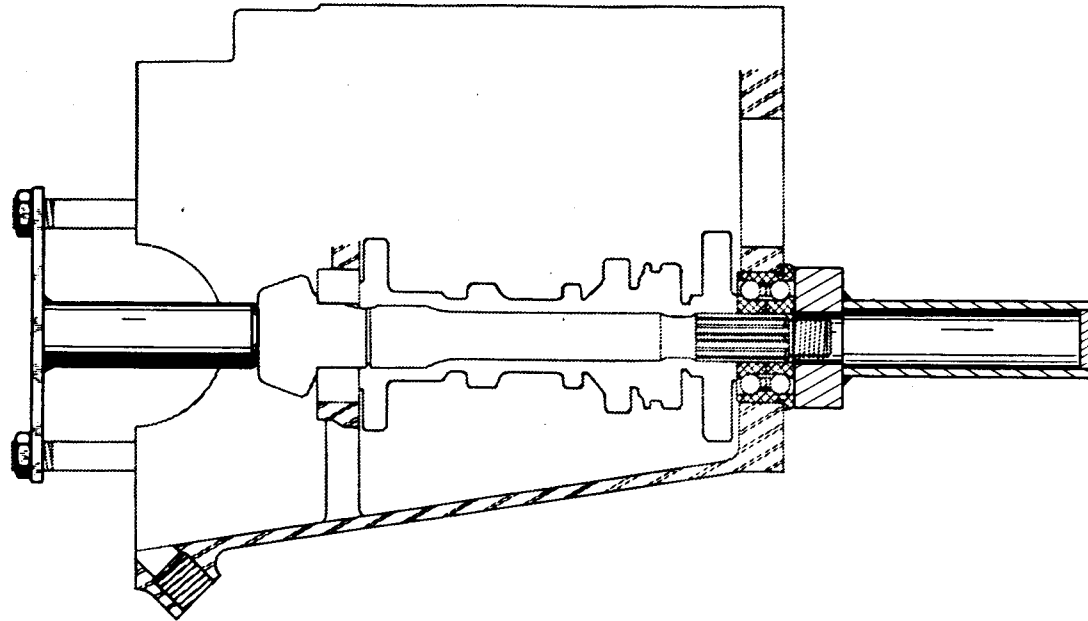

Fig. 2 - RETAINING PLATE MR-3677 Not sold.

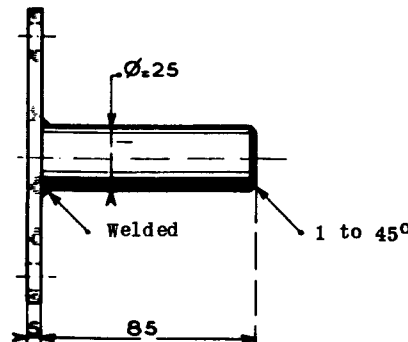
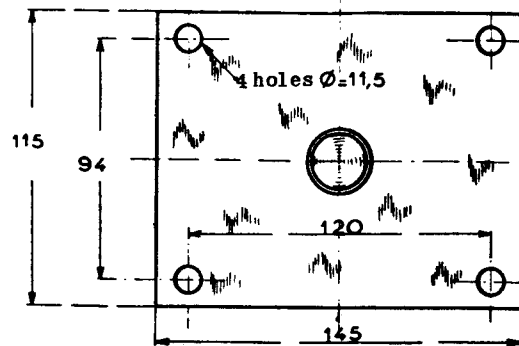
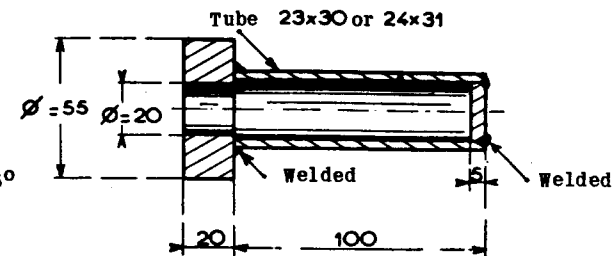

Fig. 3 - PUNCH MR-3676
Not sold.



HOLDING THE INTERMEDIATE SHAFT

Fig. 1 USE OF THE EQUIPMENT

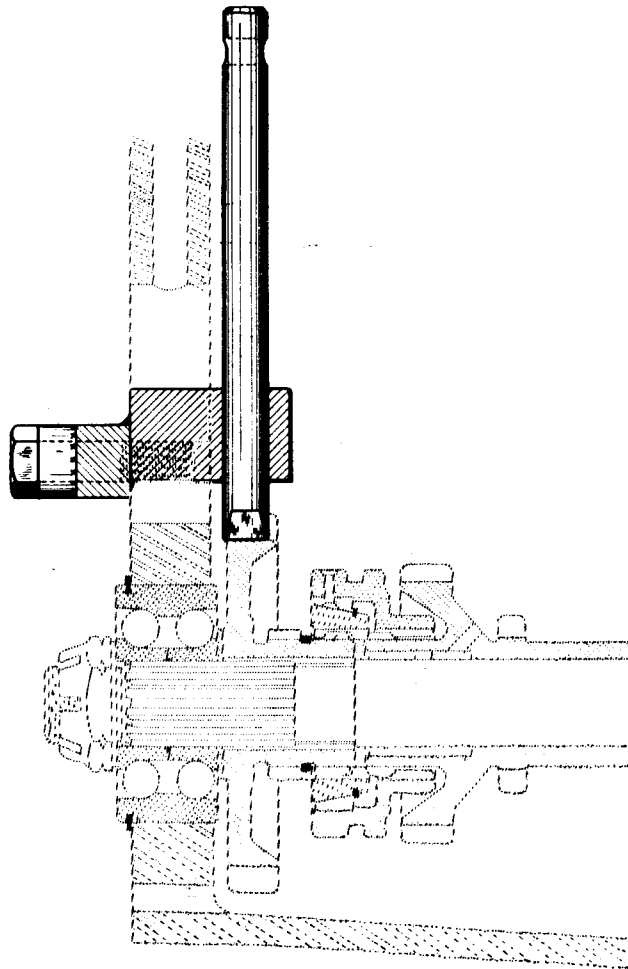
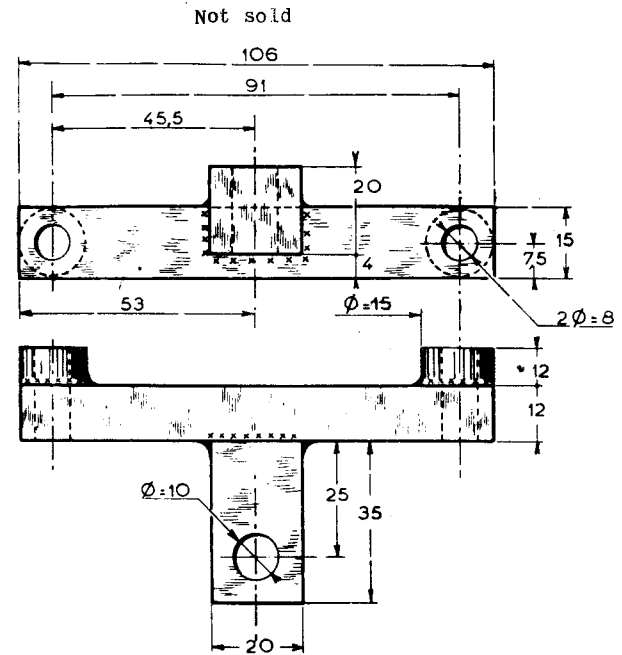
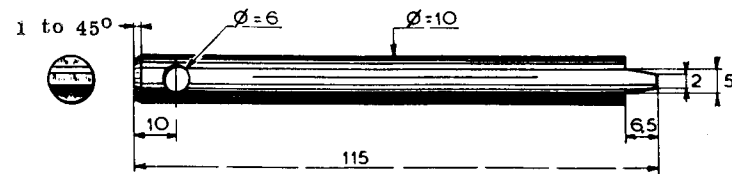

Fig. 2 TOOL NO. MR-3139 10



LOCKING ROD



ADJUSTMENT OF THE CROWN WHEEL AND BEVEL PINION

Fig. 1 - ADJUSTMENT OF THE CONICAL DISTANCE.

Fig. 2 - ADJUSTMENT OF TOOTH CLEARANCE.

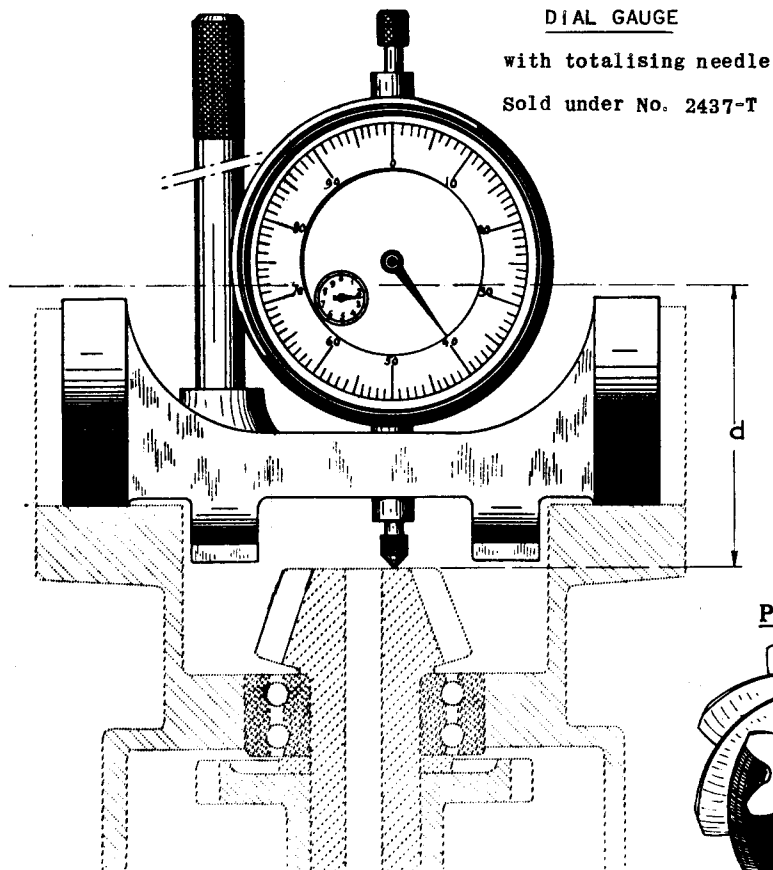

EQUIPMENT FOR ADJUSTMENT

Sold under No. 2045-VA

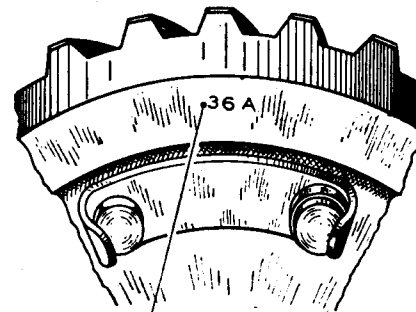
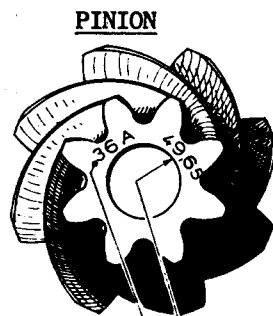
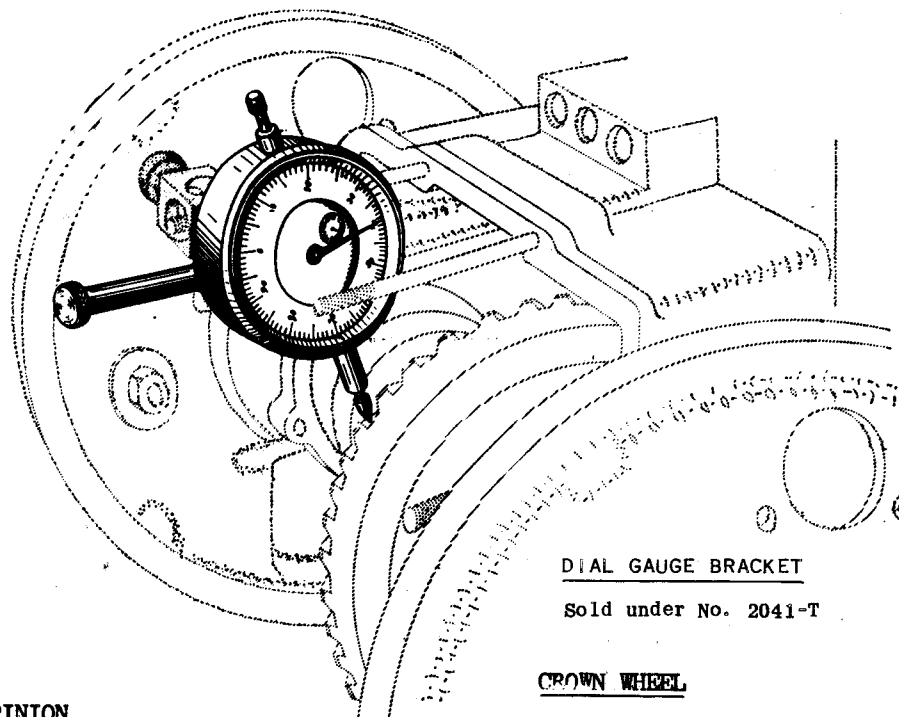

Fig. 3

ADJUSTMENT DIMENSION 'd'
FOR THIS PINION.
PAIRING NUMBER

ADJUSTMENT OF SELECTOR FORKS

Fig.1 - POSITION OF THE ADJUSTING SHIMS

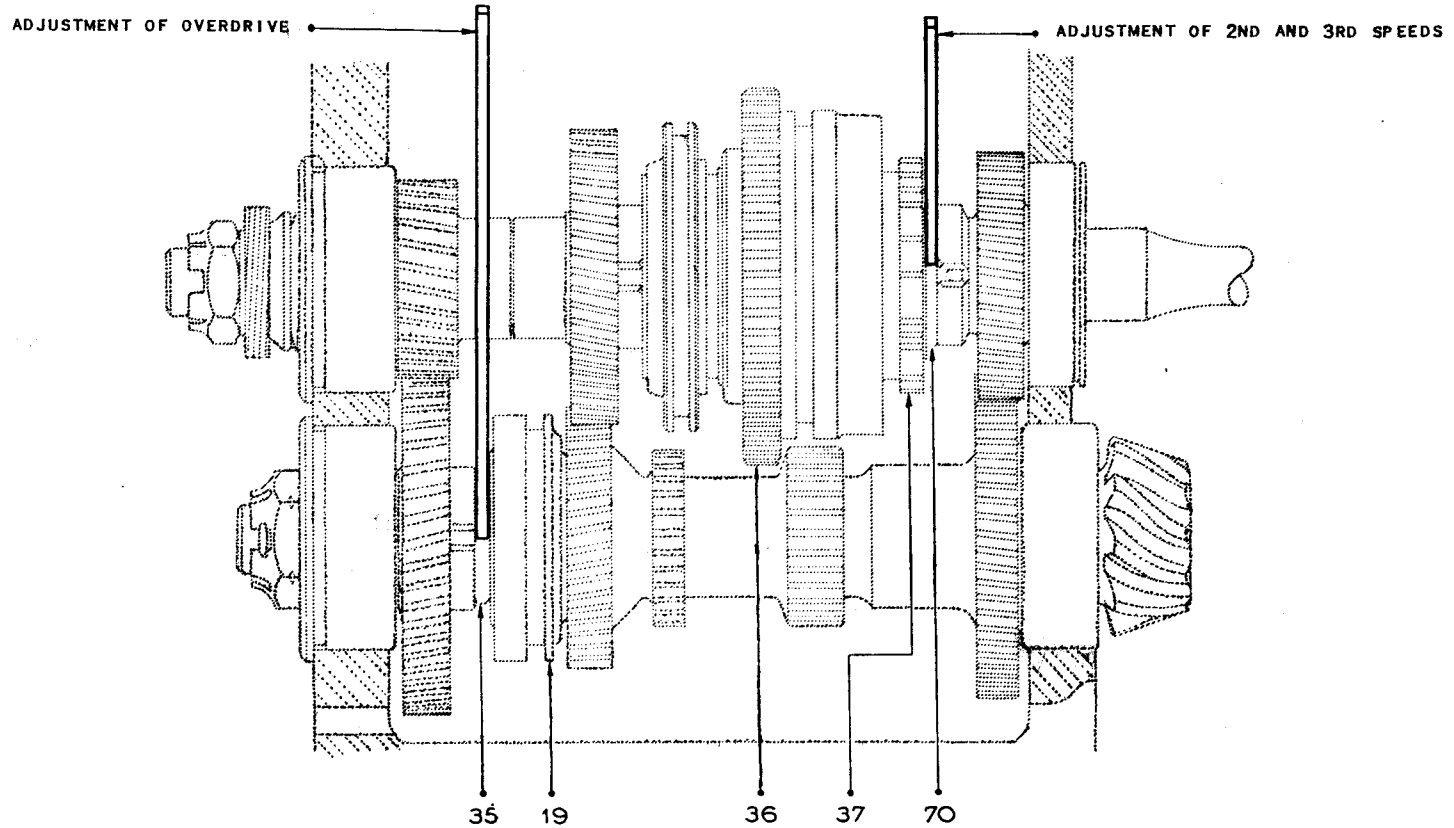

Fig 2 - ADJUSTING SHIM FOR OVERDRIVE

Sold under No. 1787-VA

THICKNESS 1MM.

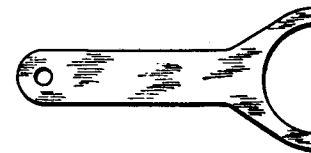

Fig. 3 - ADJUSTING SHIM FOR 2nd AND 3rd SPEEDS

Sold under No. 1785-VA

1ST TYPE THICKNESS 2.8MM.

2ND TYPE THICKNESS 1.8MM.



— ADJUSTMENT OF THE DIFFERENTIAL BEARINGS —

Fig 1

MEASURE THE DEPTH OF THE HOUSING

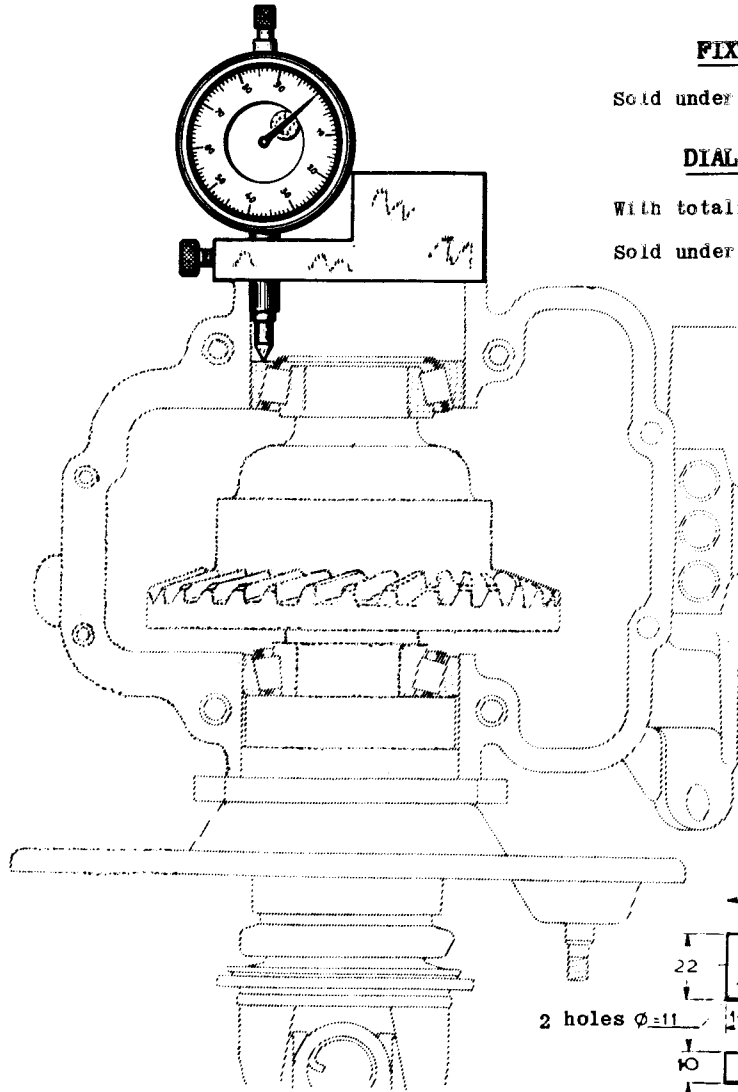
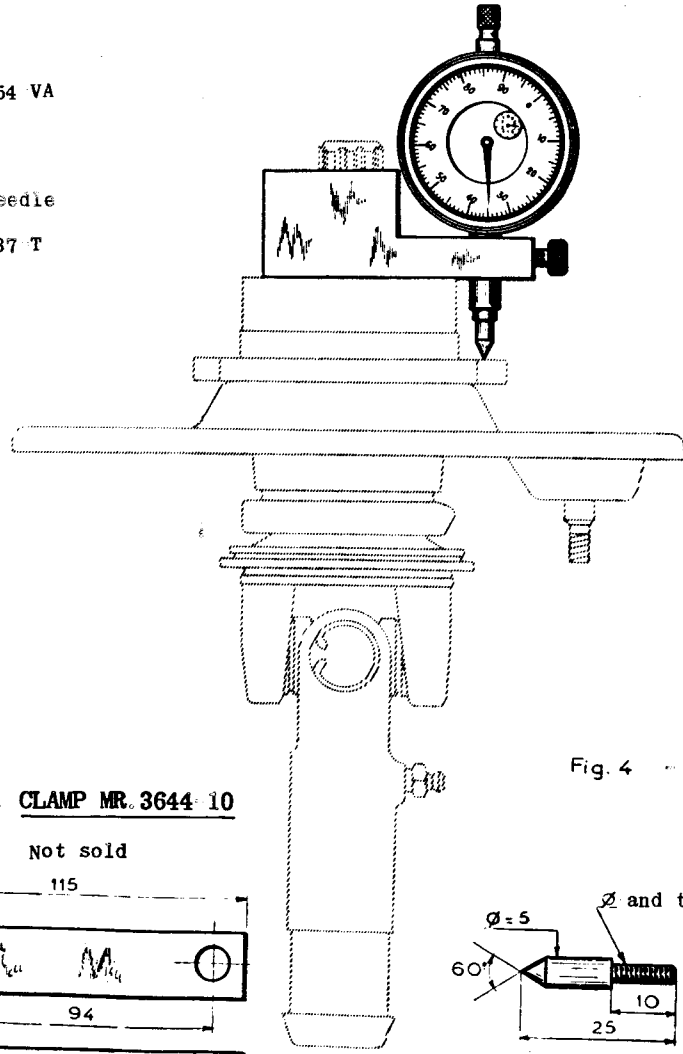

Fig. 2

MEASURE THE HEIGHT OF THE SHOULDER OF THE HUB



FIXTURE

Sold under No 1754 VA

DIAL GAUGE

With totalising needle

Sold under No. 2437 T

Fig. 3 - CLAMP MR. 3644 10

Not sold

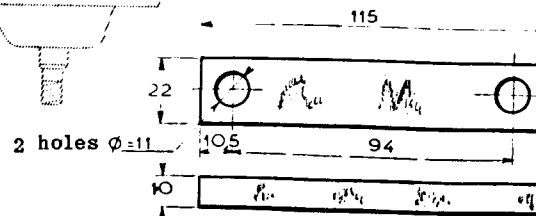
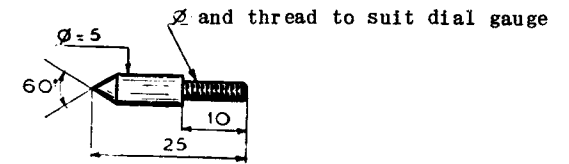

Fig. 4 - EXTENSION MR. 3365 10

Not sold



— GEARBOX —

— ADJUSTMENT OF THE DIFFERENTIAL BEARING —

POSITION OF THE BOX

FOR ADJUSTMENT.

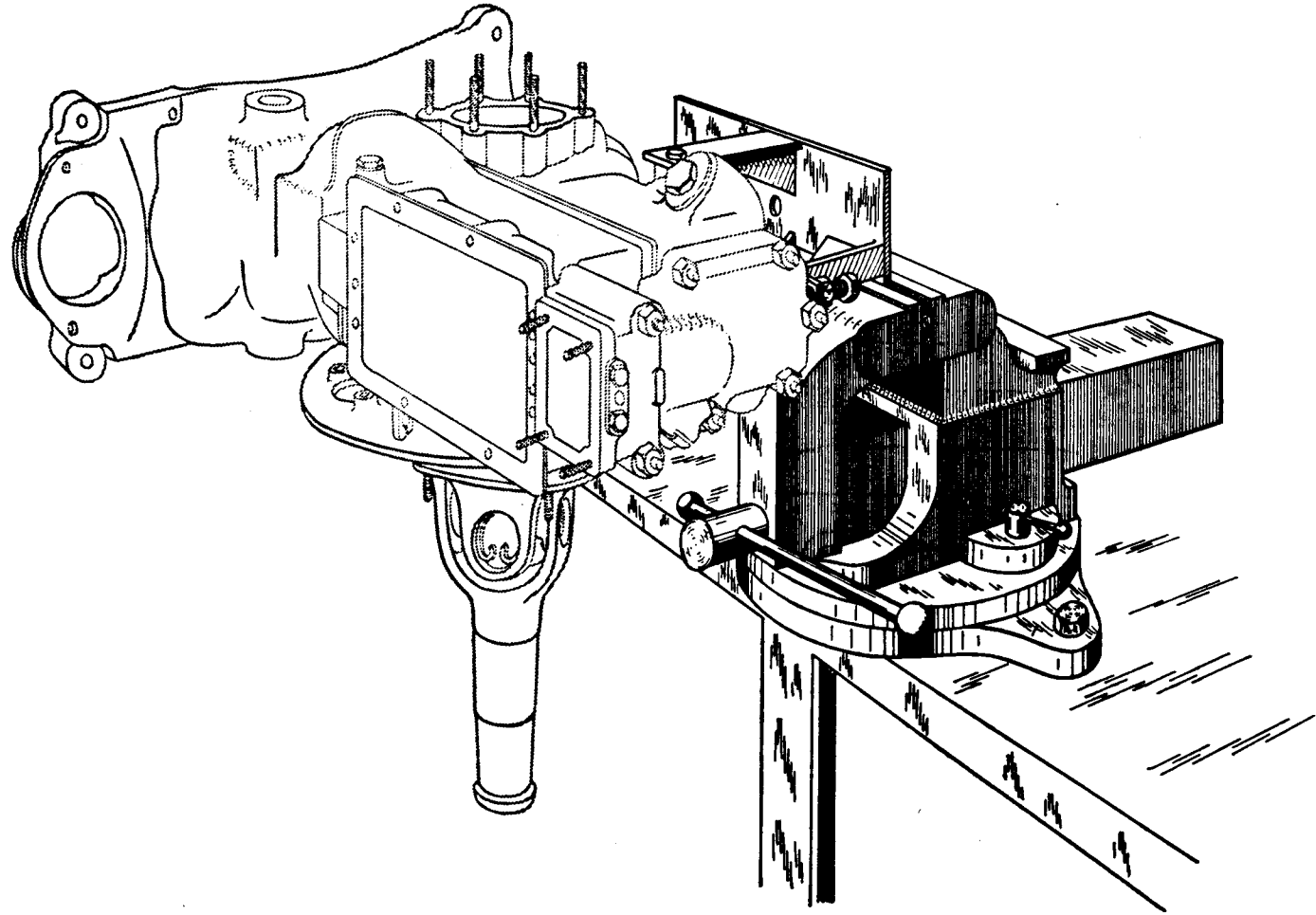

— CENTERING THE BRAKE LININGS —

Fig. 1 — CHECKING THE DIAMETER OF THE DRUM

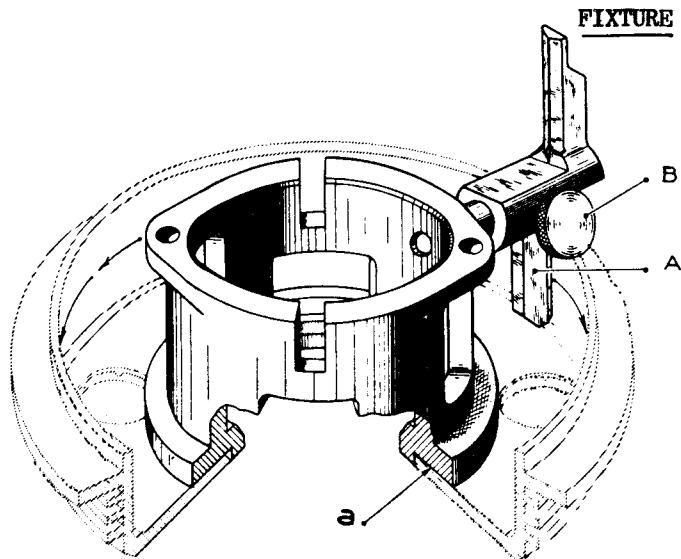

FIXTURE Sold under No. 2112 VA

PUT THE FIXTURE IN POSITION IN THE DRUM, BRING THE INDEX A INTO CONTACT WITH THE DRUM AND TURN IT ROUND ONE COMPLETE REVOLUTION. LOCK THE INDEX IN THIS POSITION BY MEANS OF THE KNURLED SCREW B

NOTE: LIGHTLY OIL AT 'a' TO FACILITATE THE ROTATION OF THE FIXTURE.

Fig. 2 — INSPECTION OF CENTERING

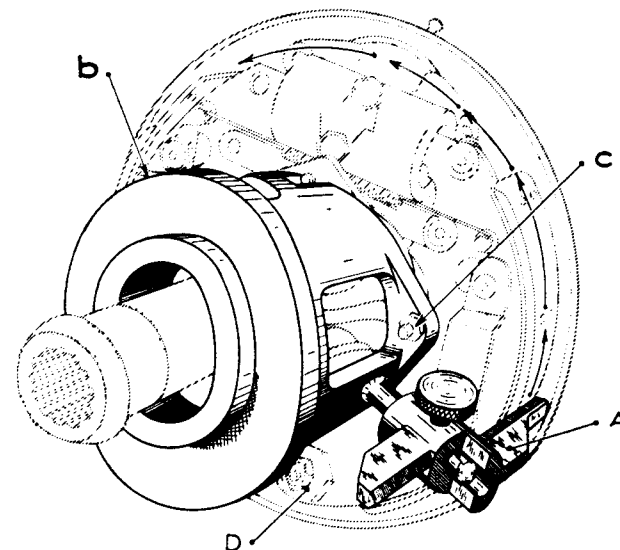

REMOVE THE GREASER FROM THE SLIDING COUPLING. OFFER UP THE FIXTURE AGAINST THE DRIVING PLATE AND FIX IT BY MEANS OF THE TWO NUTS AT 'b' AND 'c'.

OFFER UP THE INDEX A, LOCKED AT THE PREVIOUS OPERATION, THE INDEX SHOULD BE LEVEL WITH THE LININGS THROUGHOUT THEIR CIRCUMFERENCE (IF NECESSARY MOVE THE LINING IN THE REQUIRED DIRECTION BY ADJUSTING THE ECCENTRIC D AND THE ADJUSTING CAM - NOT SHOWN ON SKETCH). REMOVE ANY HIGH SPOTS WITH A RASP.

REMOVE THE FIXTURE AND REPLACE THE GREASER.

AFTER INSPECTION LOOSEN THE CAMS SO AS TO ALLOW THE DRUM TO BE FITTED.

— GEARBOX —

— POSITION OF GEARS FOR EACH SPEED —

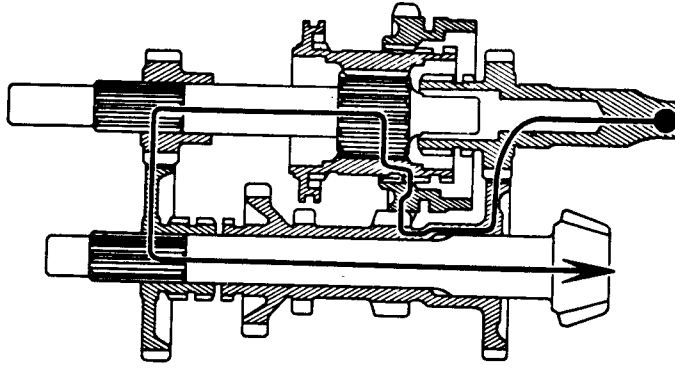
Fig. 1 - FIRST SPEEDFig. 2 - REVERSE

THESE TWO
PINIONS ARE IN
MESH

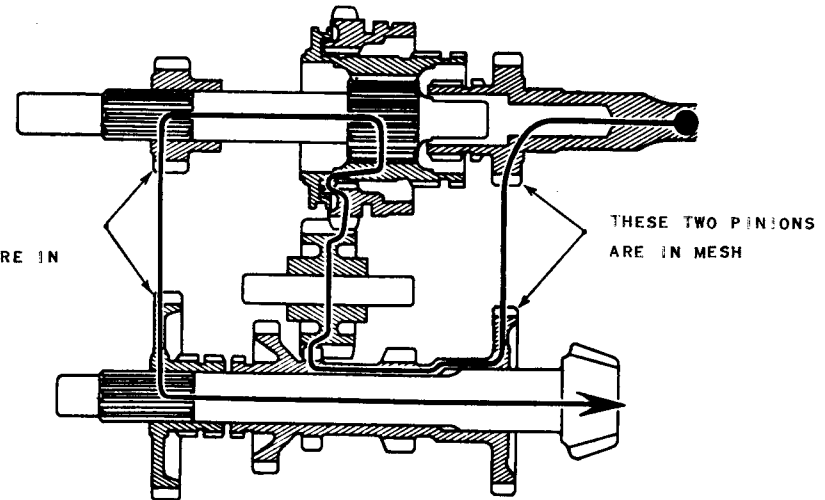

THESE TWO PINIONS
ARE IN MESH

— POSITION OF GEARS FOR EACH SPEED —

Fig. 1 - SECOND SPEED

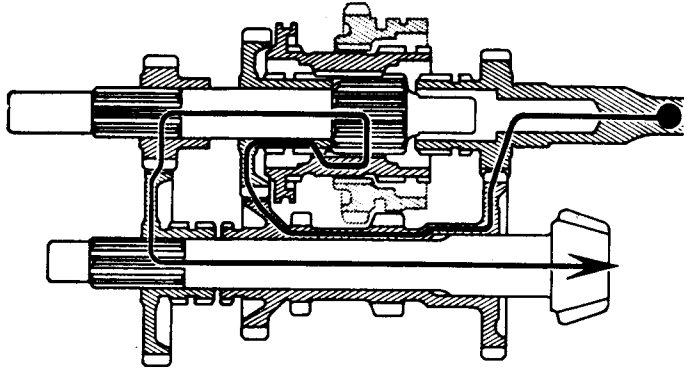

Fig. 2 - THIRD SPEED

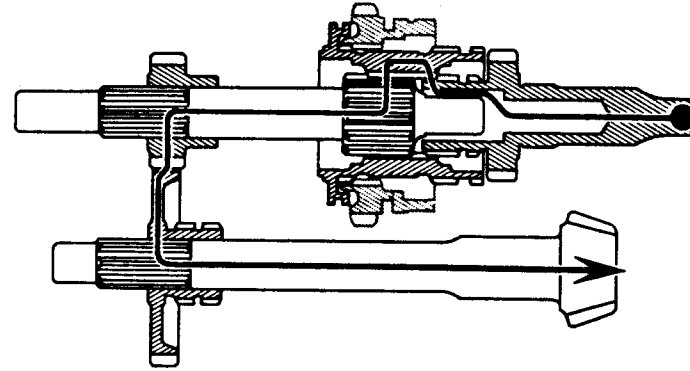
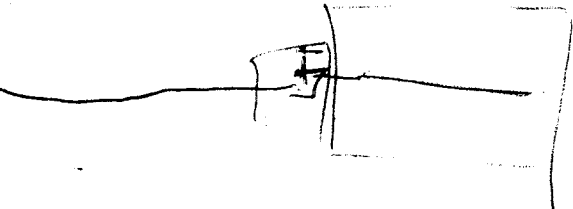
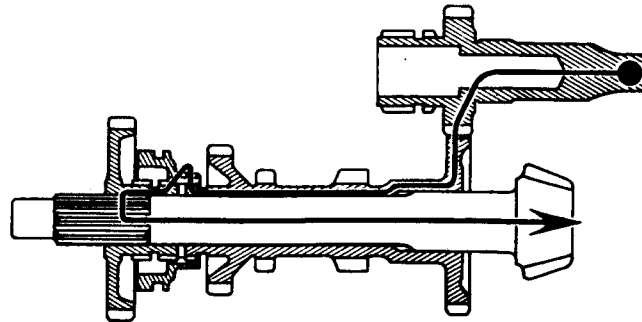

Fig. 3 - OVERDRIVE



— FRONT AND REAR AXLES —

— SECTION OF HUB OF ARM —

Fig. 1

Fig. 2

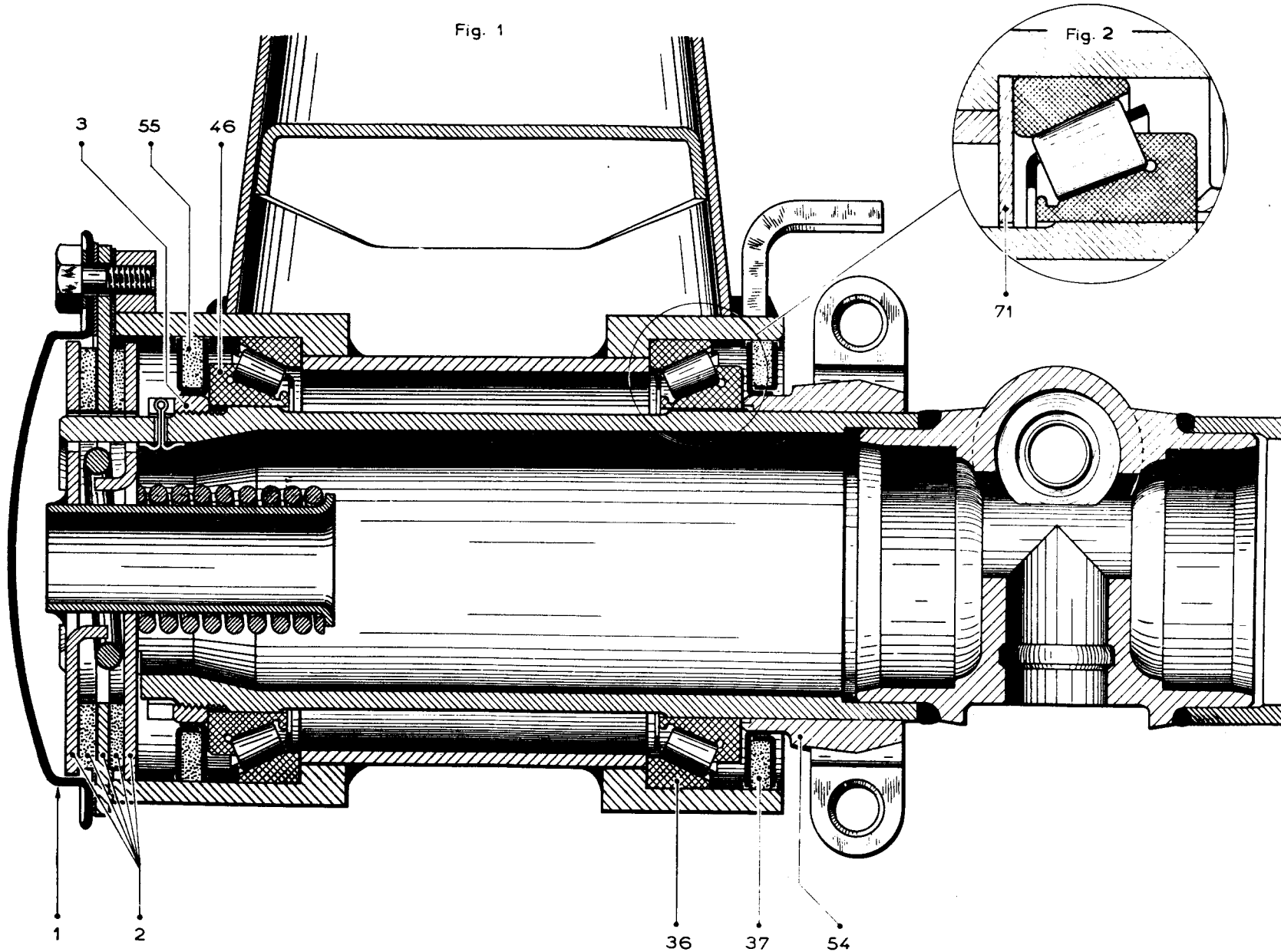

ASSEMBLY OF THE FRICTION DISCS

Fig. 1

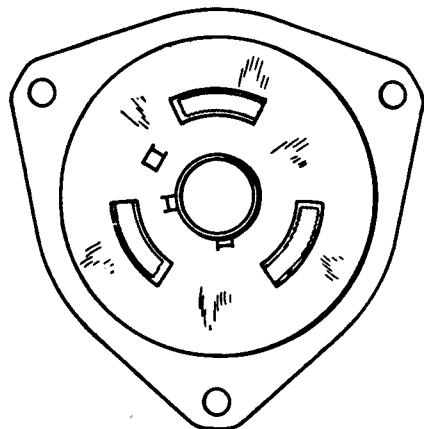

FIT THE INSIDE DISC OF THE FRICTION DISC ON THE THREE TENONS ON THE AXLE CROSSMEMBER

Fig. 2

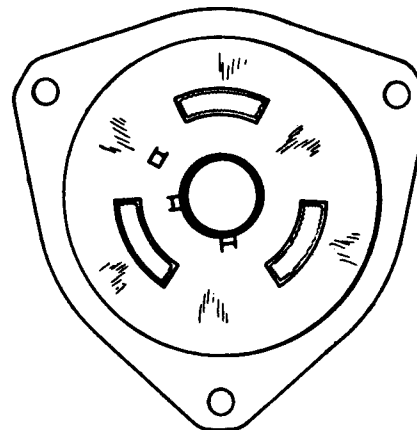

TURN THE OUTSIDE DISC WITH THE SPANNER 1834-VA SO AS TO BRING THE SLOTS OPPOSITE THE TENONS ON THE AXLE CROSSMEMBER. PUSH THE ASSEMBLY AS FAR AS POSSIBLE ON TO THE TENONS

Fig. 3 - SPRING BALANCE

Sold under No. 2472-T

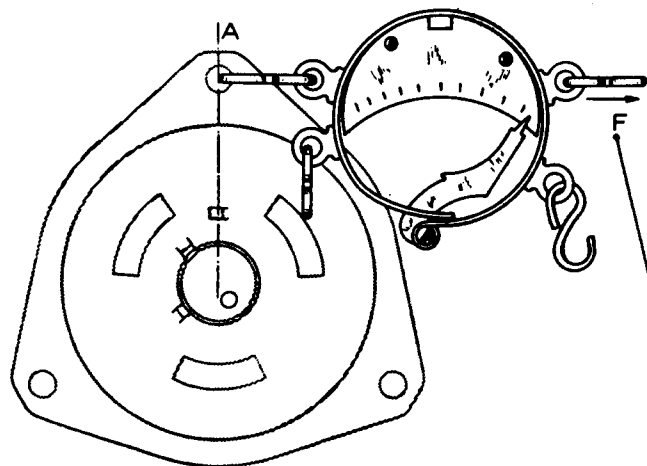

THE PULL F SHOULD BE AT RIGHT ANGLES TO THE RADIUS OA

— ASSEMBLY OF ARMS AND FRICTION DISCS —

Fig. 1 - DISMANTLING - ASSEMBLING
AND ADJUSTMENT OF ARMS

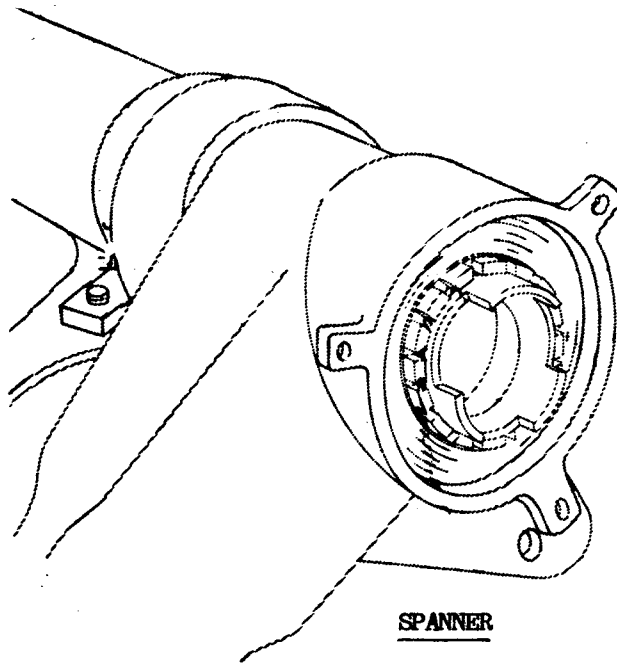

SPANNER
Sold under No. 1833-VA

Fig. 2 - FITTING FRICTION DISCS

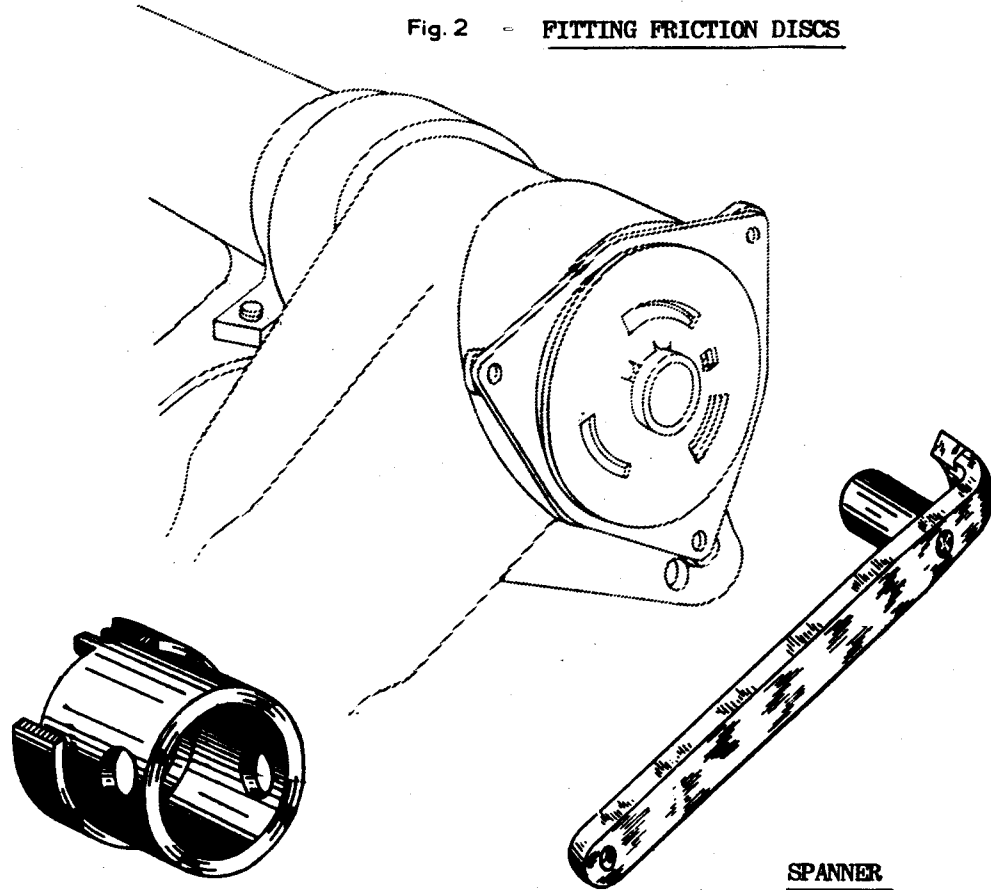

SPANNER
Sold under No. 1834-VA

LIFTING OF VEHICLE

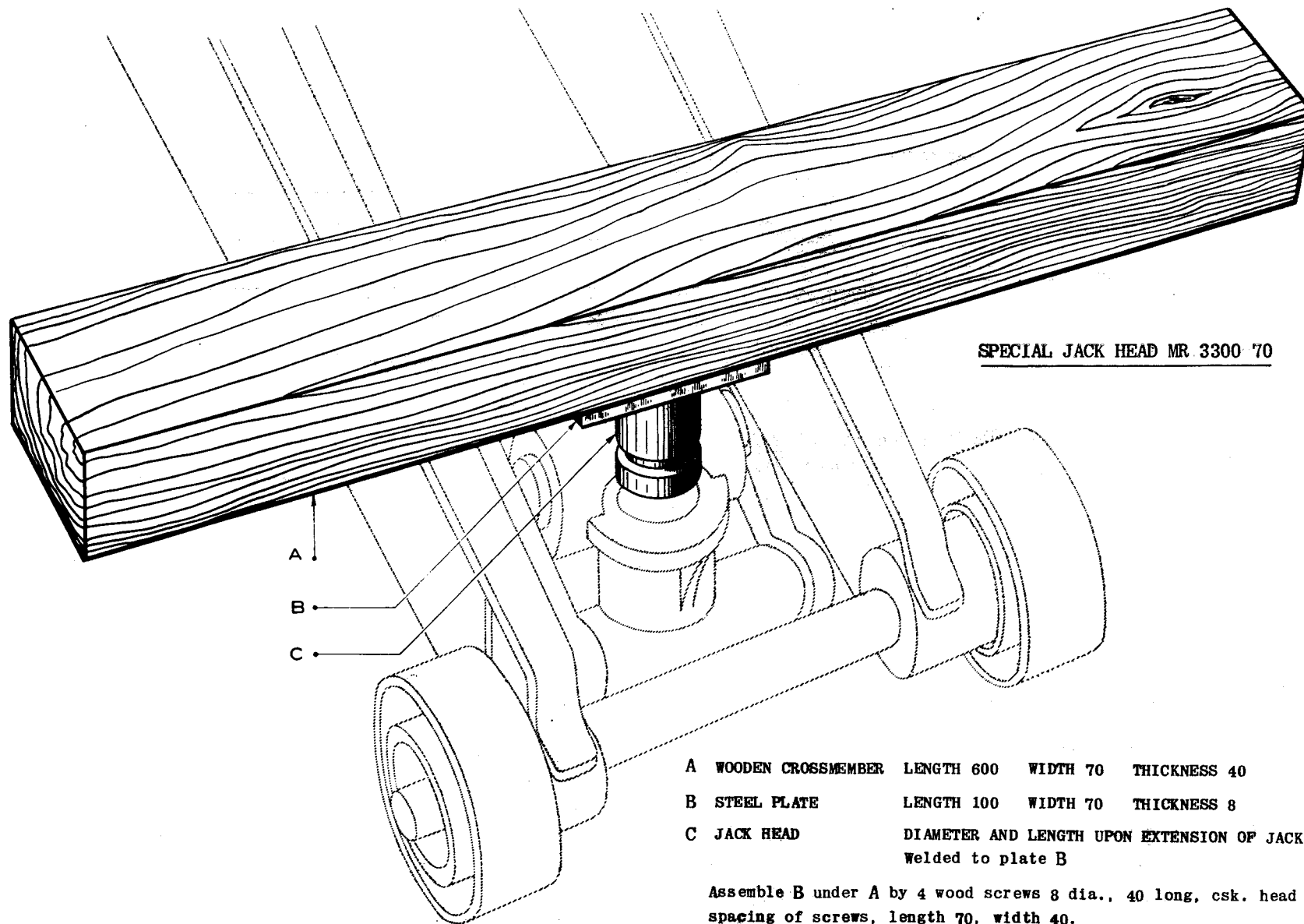

SPECIAL JACK HEAD MR 3300 '70

- A WOODEN CROSSMEMBER LENGTH 600 WIDTH 70 THICKNESS 40
- B STEEL PLATE LENGTH 100 WIDTH 70 THICKNESS 8
- C JACK HEAD DIAMETER AND LENGTH UPON EXTENSION OF JACK welded to plate B

Assemble B under A by 4 wood screws 8 dia., 40 long, csk. head spacing of screws, length 70, width 40.

— FRONT AXLE - STEERING —

— SECTION OF HUB AND SWIVEL —

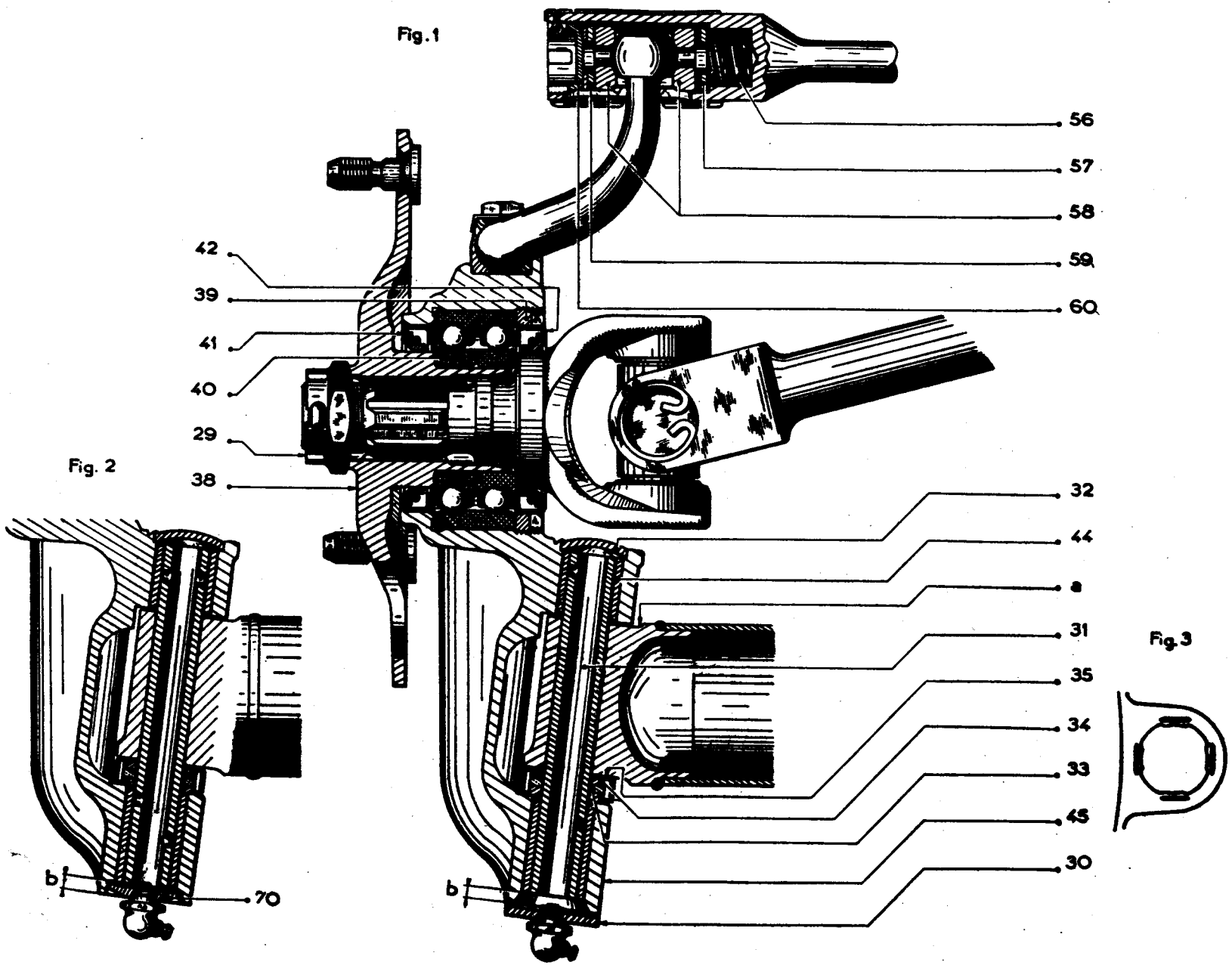

VARIOUS TOOLS

Fig 1 - ASSEMBLY OF BALLRACE

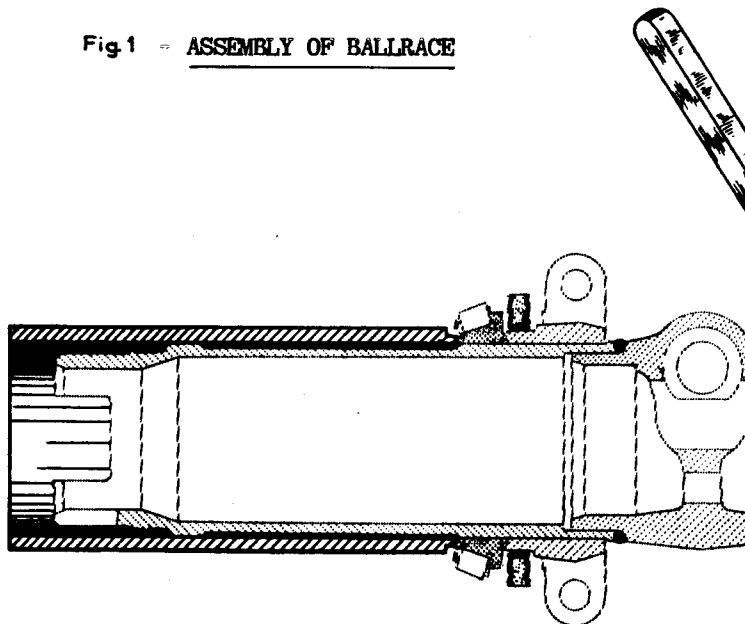

Fig 2 - ADJUSTMENT OF BALL JOINT

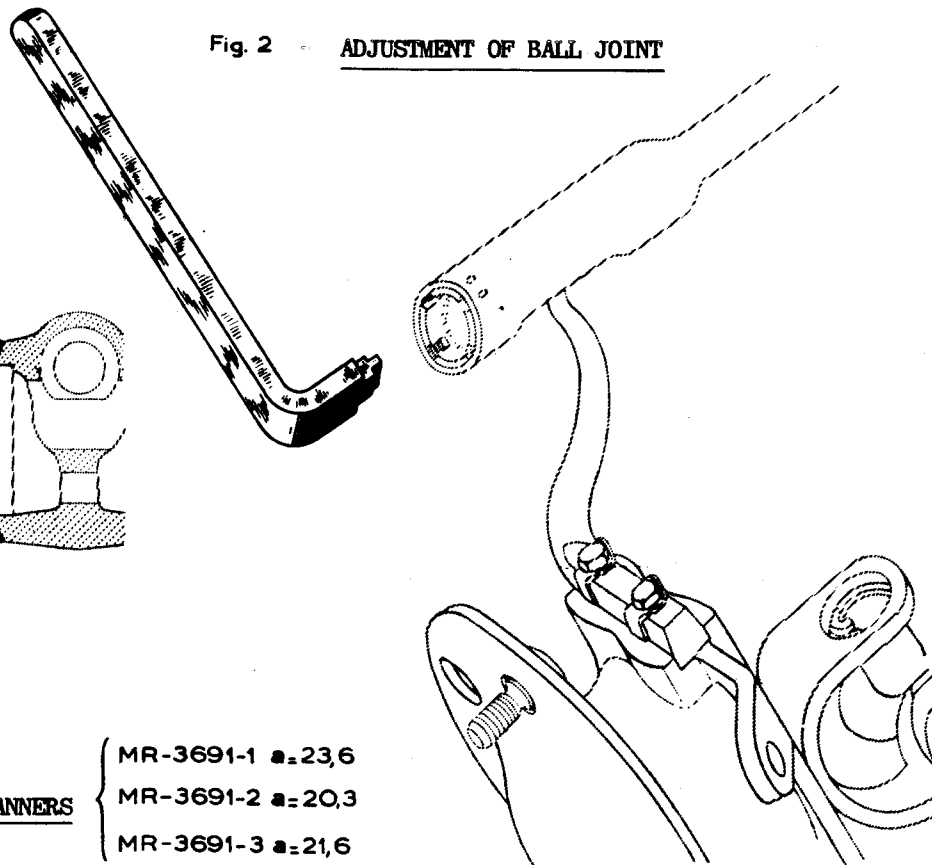
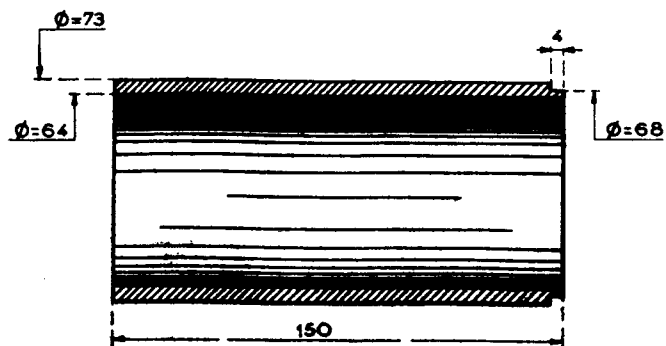

Fig 3 - TUBE MR 3616-20

Not sold



SPANNERS

- MR-3691-1 a=23,6
- MR-3691-2 a=20,3
- MR-3691-3 a=21,6

Not sold

THESE THREE SPANNERS ARE USED IN THE SAME MANNER

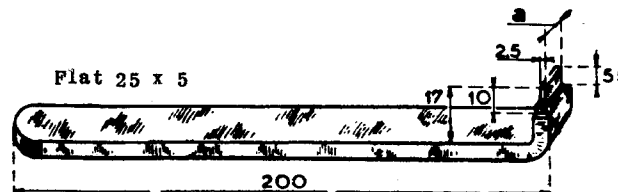

FRONT AXLE - STEERING

REMOVING AND FITTING THE KING PIN

Fig. 1 - METHOD OF USING THE EQUIPMENT

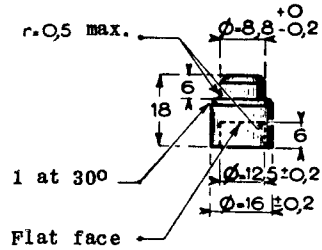
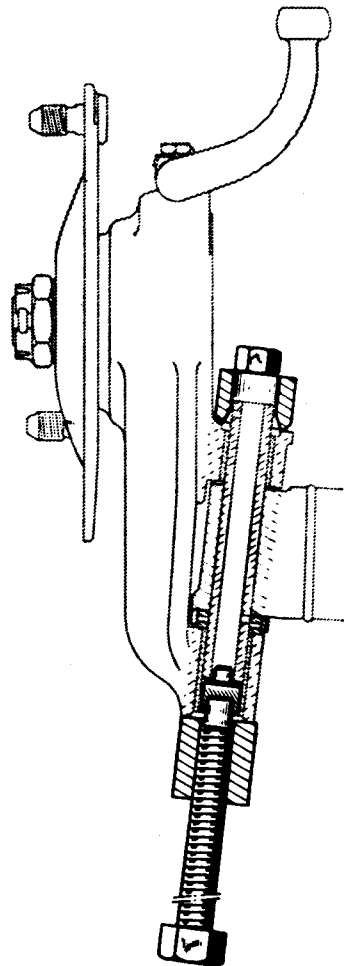

SCREW AND PAD HEAT TREATED TO GIVE TENSILE STRENGTH 100KG/MM2

Fig. 2 - EQUIPMENT FOR THE KING PIN MR. 3742

Not sold

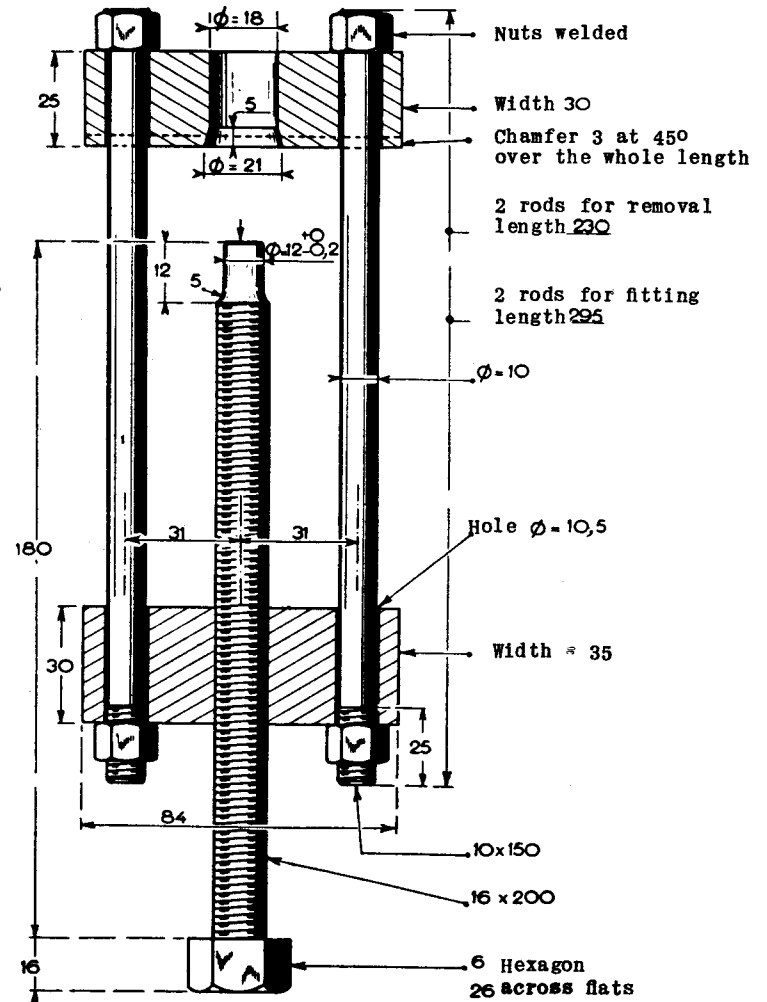

— FRONT AXLE —

— CHECKING ARM —

Fig. 2 POSITION OF STOP

Fig. 1 UTILIZATION OF ASSEMBLY

ASSEMBLY MR. 3745

Not sold

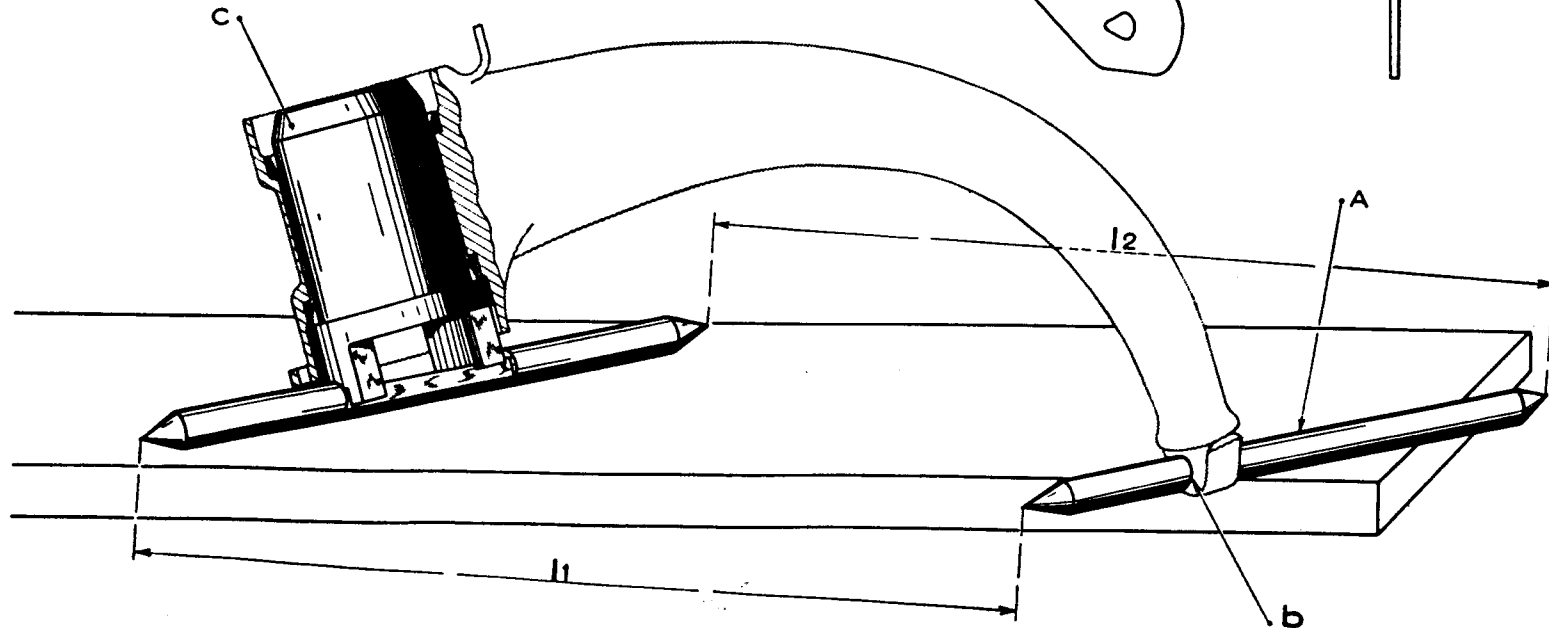
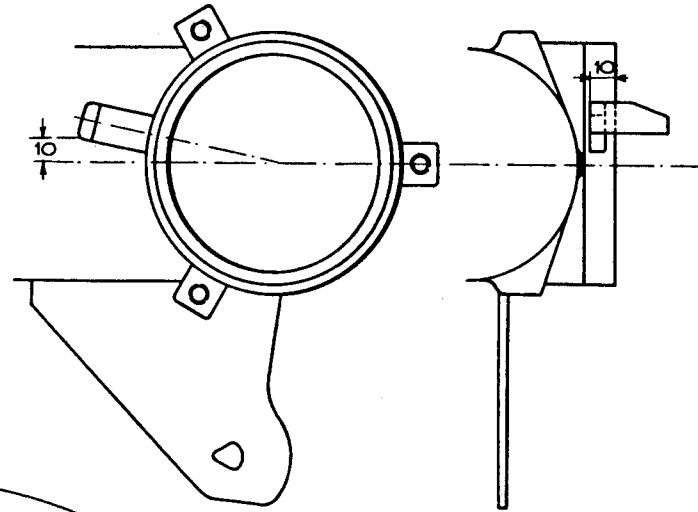

CONSULT THE REPAIR MANUAL FOR THE MAIN DIMENSIONS

— FRONT AXLE - STEERING —

— SECTION OF THE STEERING GEAR —

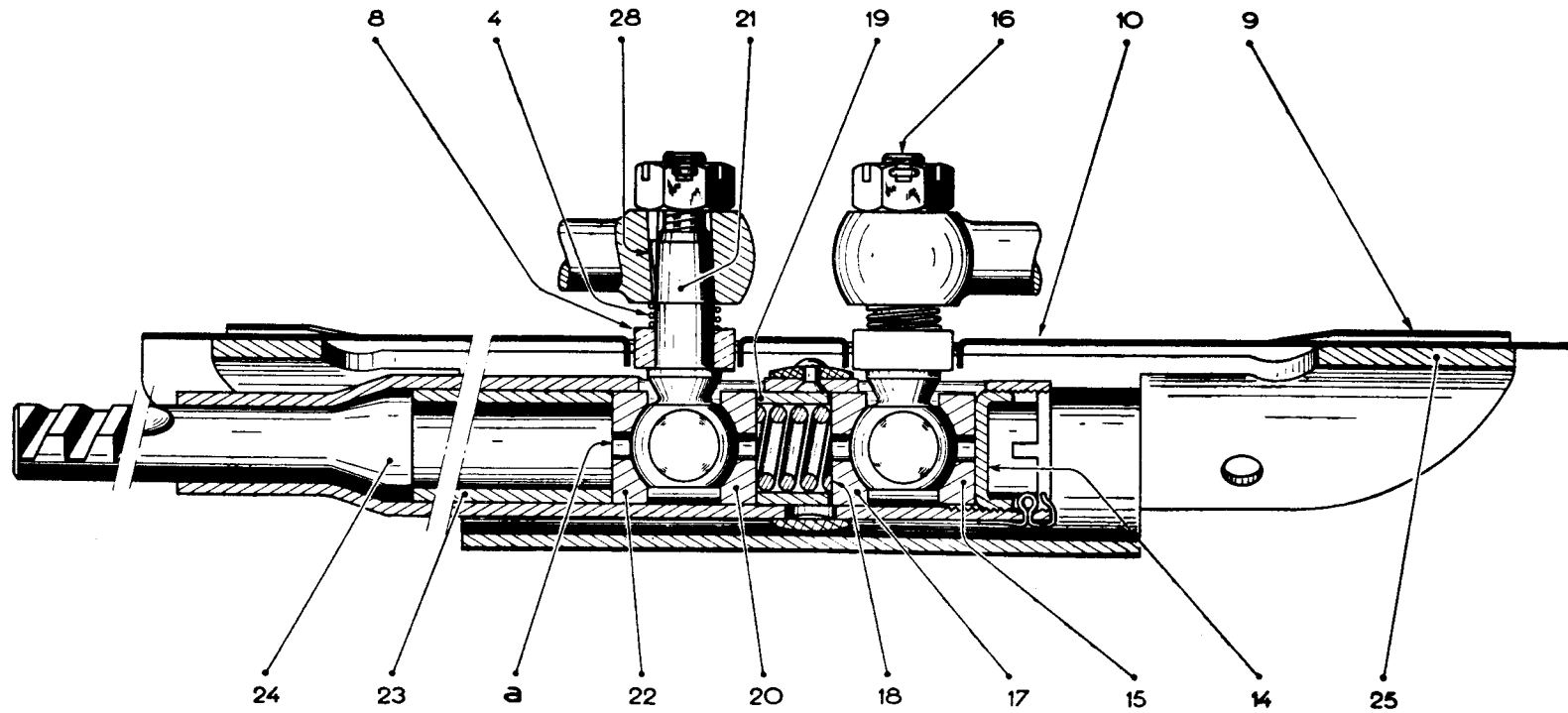

— SECTION OF THE STEERING GEAR —

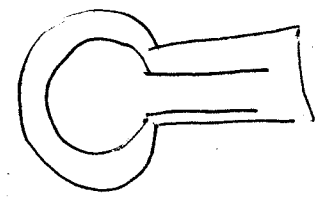
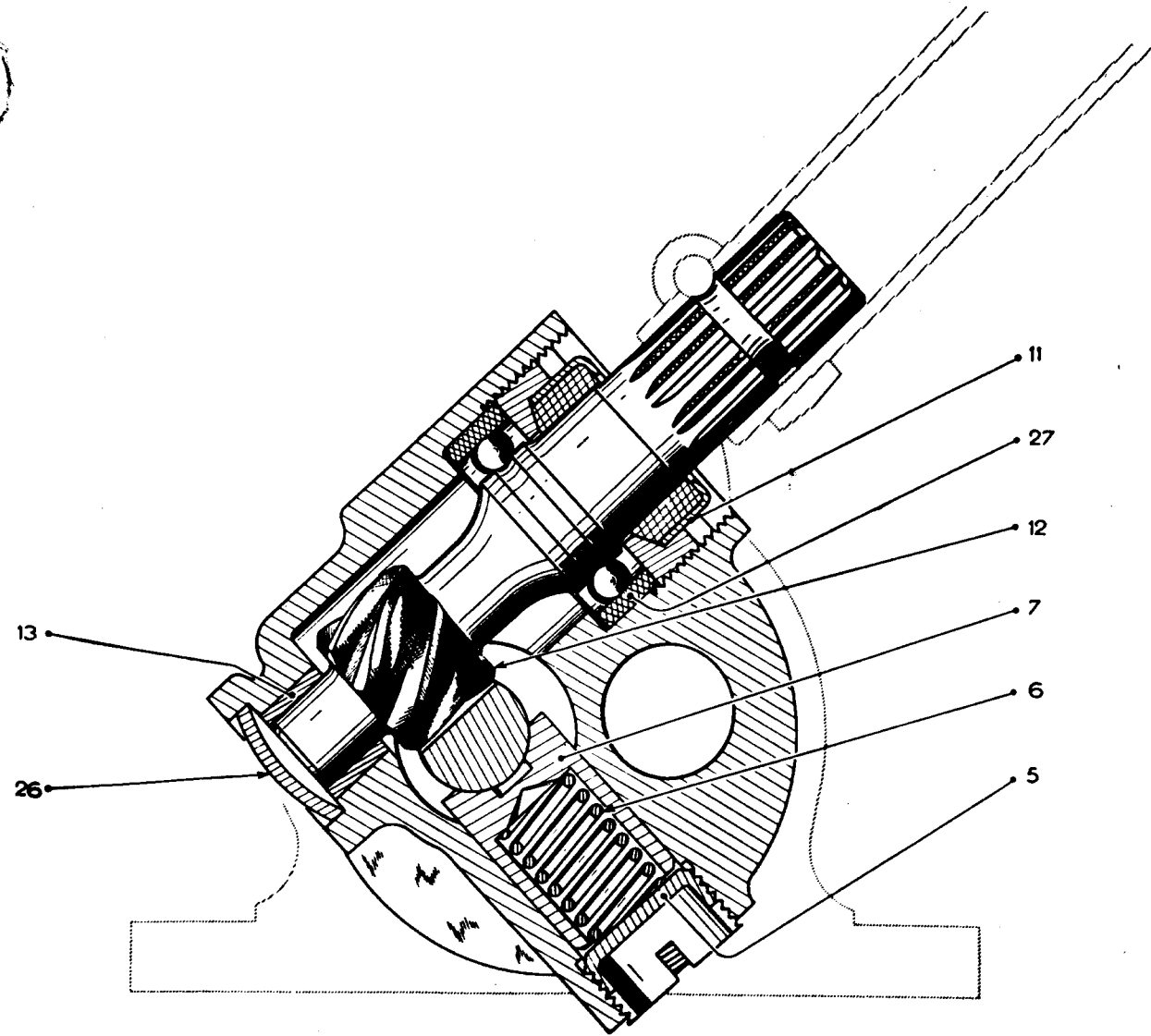

— FRONT AXLE AND STEERING —

— REMOVAL OF THE STEERING WHEEL —

Fig.1 - METHOD OF USE

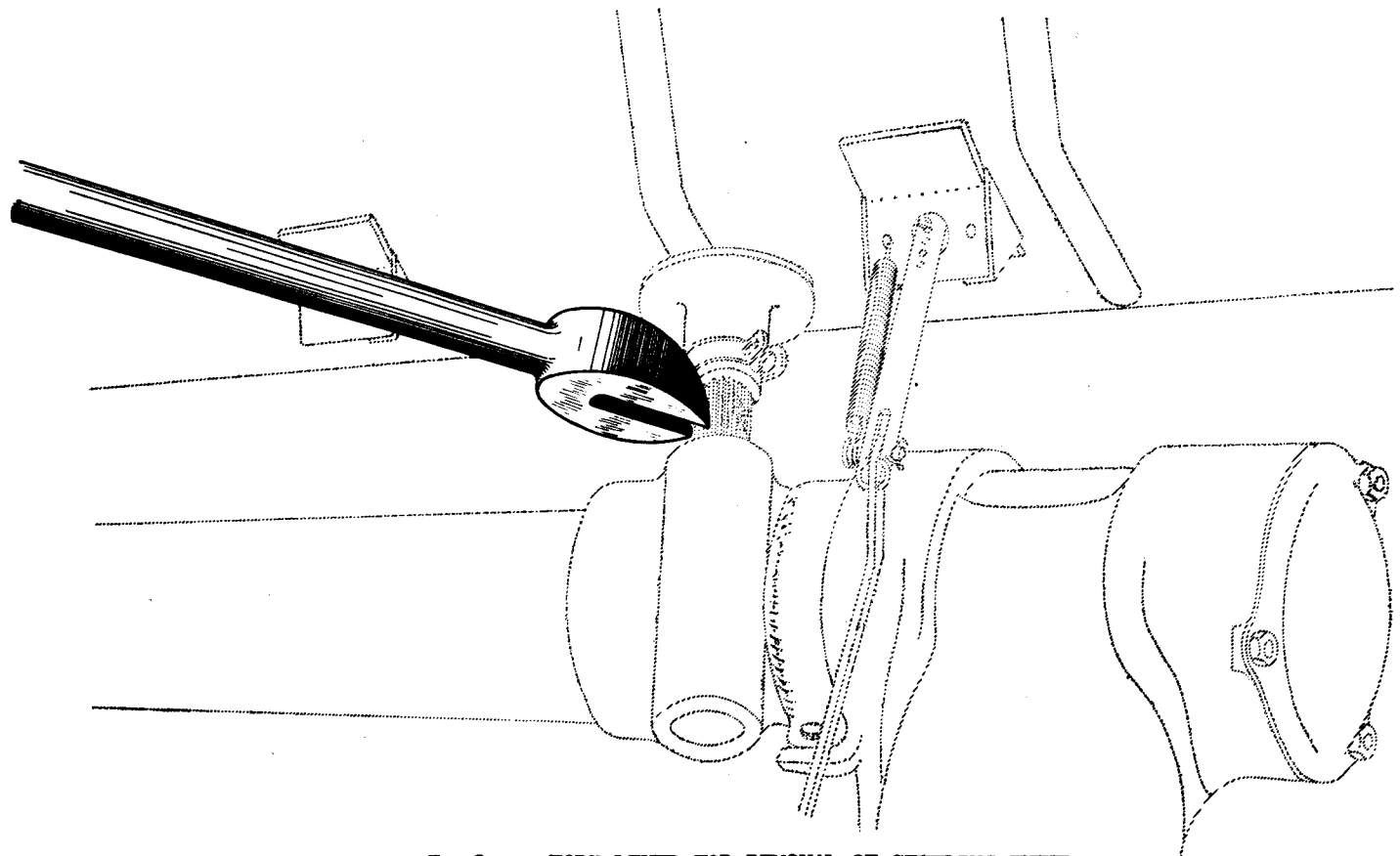

Fig.2 - FORK LEVER FOR REMOVAL OF STEERING WHEEL

Sold under No. 1951-VA



— FRONT AND REAR AXLES —

— STAND FOR AXLE ASSEMBLY —

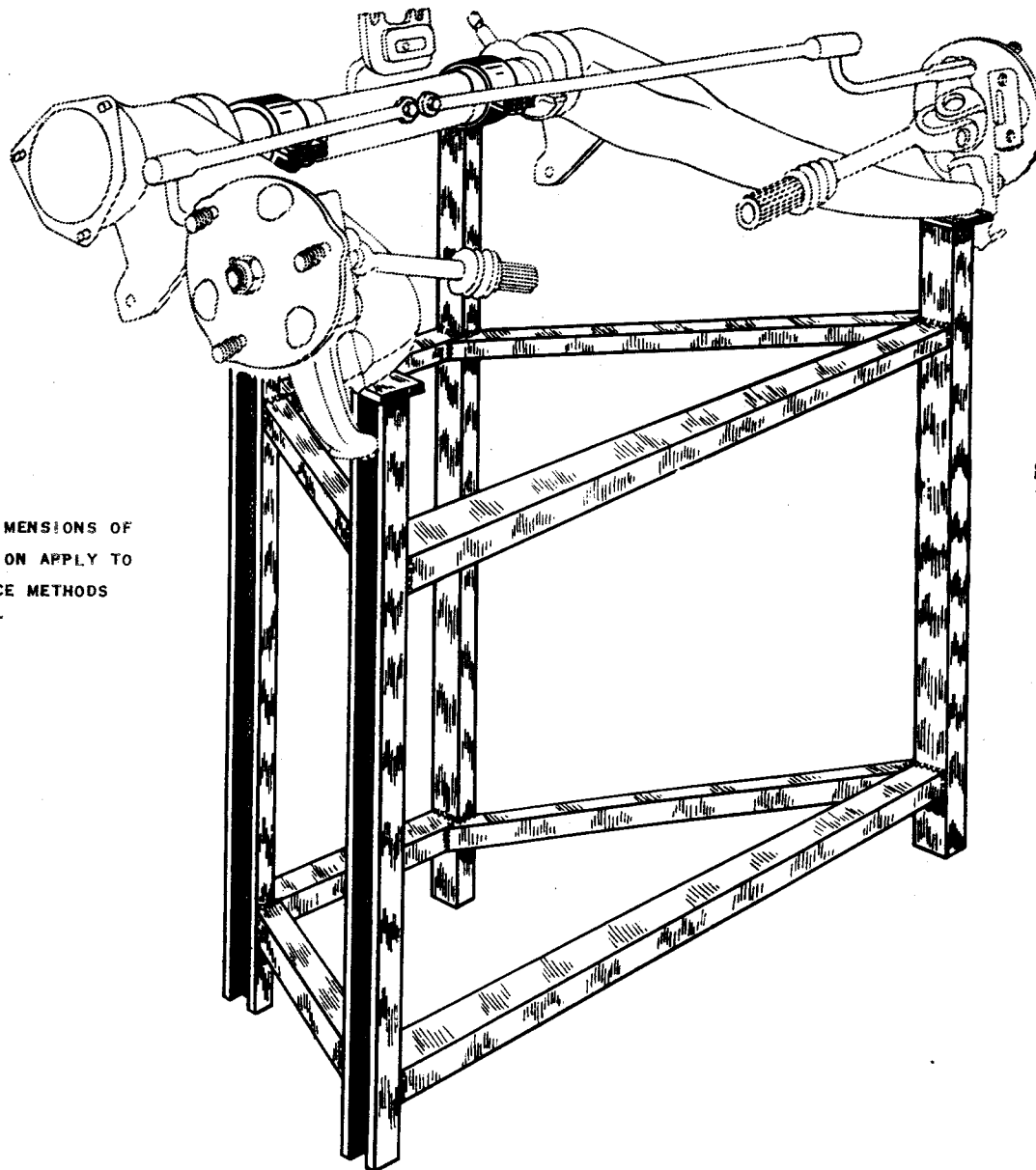

FOR THE DIMENSIONS OF
CONSTRUCTION APPLY TO
THE SERVICE METHODS
DEPARTMENT

LAND 59
NOT
WITHOUT
A WASHER

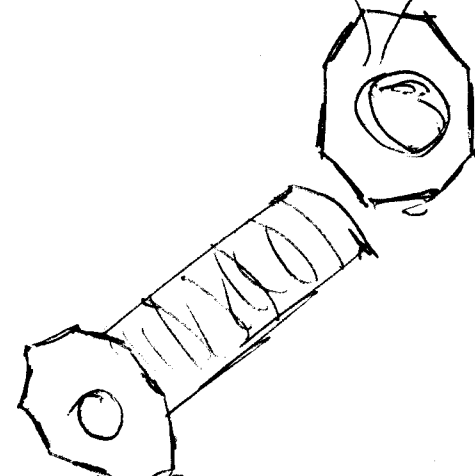

STAND MR. 3301-60

Not sold

— VARIOUS TOOLS —

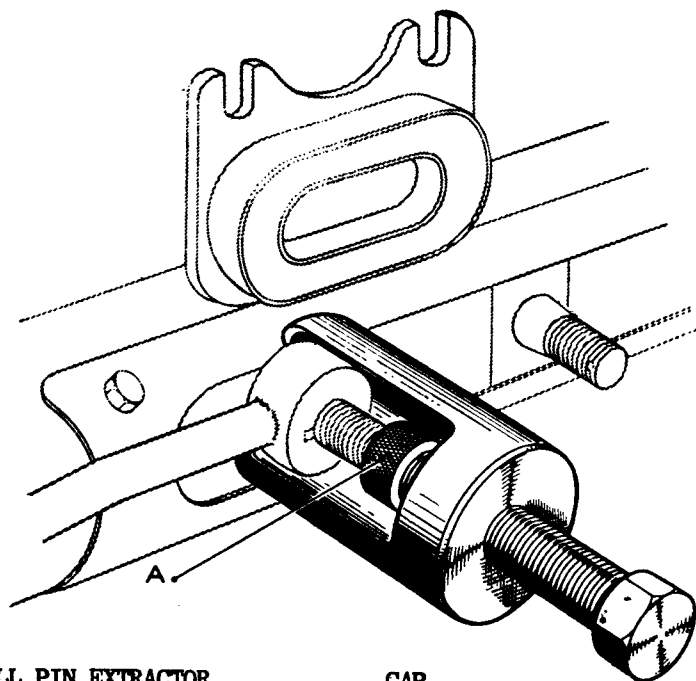
Fig. 1 — REMOVAL OF STEERING TIE RODSBALL PIN EXTRACTOR

Sold under No. 1964-T

CAP

Sold under No. 1965-VA

SCREW THE CAP A ON THE THREAD OF THE BALL PIN TO
AVOID DAMAGE TO THE THREAD AND THEN FIT THE EXTRACTOR

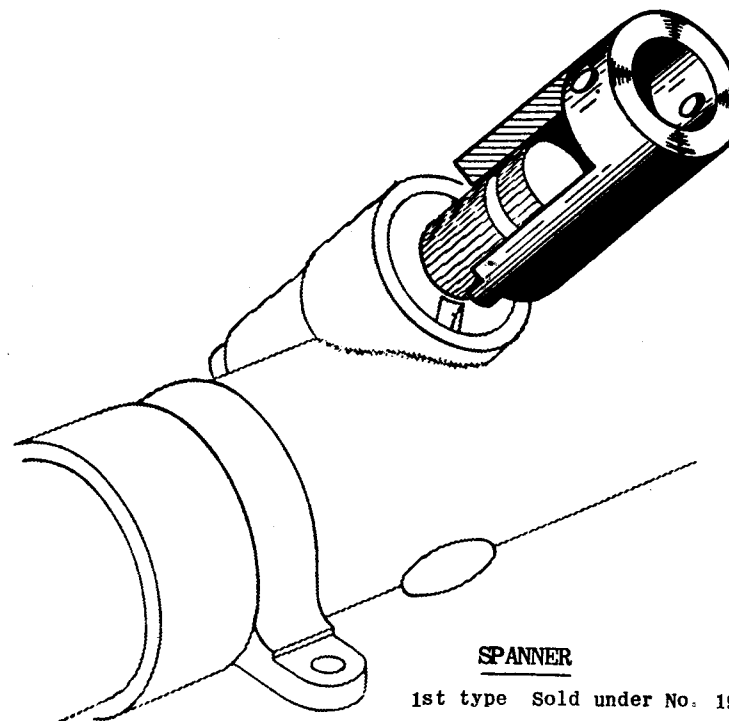
Fig. 2 — TIGHTENING THE RACK PINION NUTSPANNER

1st type Sold under No. 1980-VA

2nd type Sold under No. 1981-VA

— REMOVAL OF THE INTERIOR BEARING —

METHOD OF USING EQUIPMENT

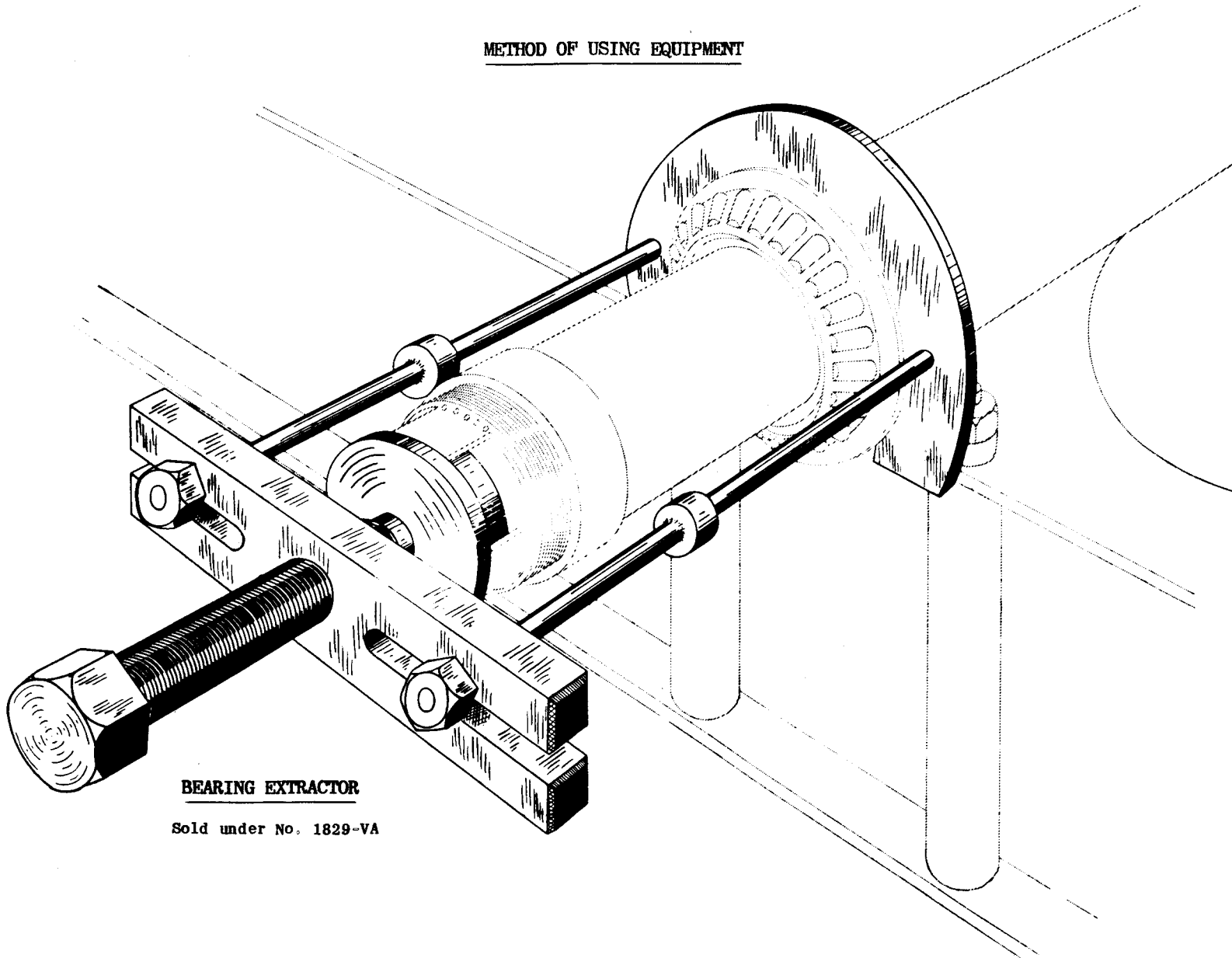

BEARING EXTRACTOR

Sold under No. 1829-VA

VARIOUS TOOLS

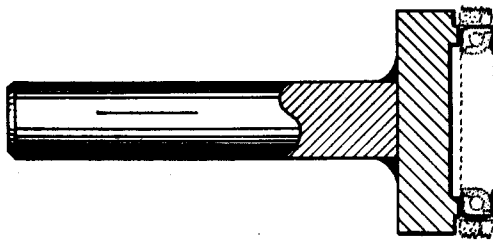
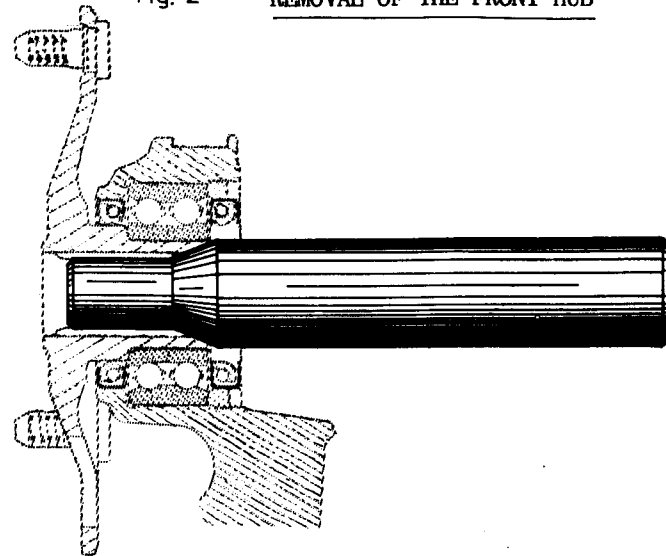
Fig. 1 - FITTING THE FRONT HUB OIL SEALFig. 2 - REMOVAL OF THE FRONT HUBFig. 3 - PUNCH MR. 3676-10

Not sold

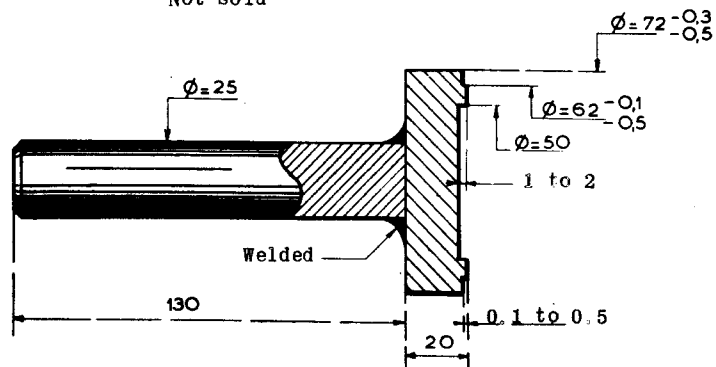
Fig. 4 - MANDREL MR. 3436-40

Not sold

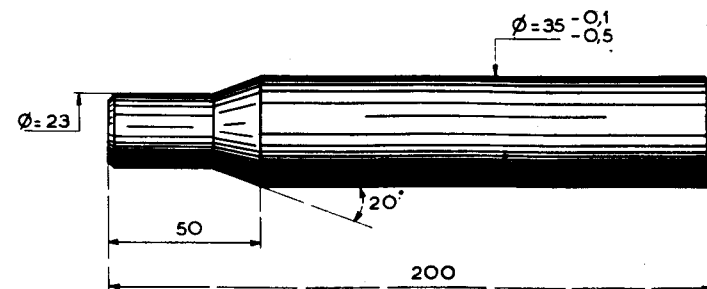

UNIVERSAL JOINT - WHEEL END

SECTION

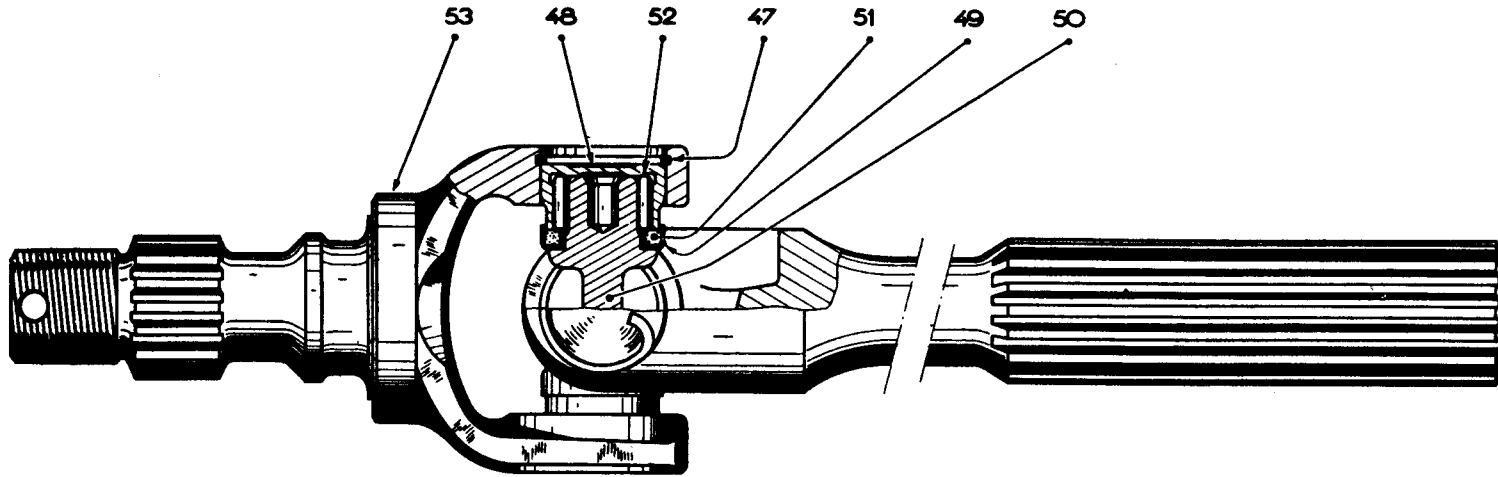

— REAR AXLE —

— SECTION OF HUB AND BRAKE DRUM —

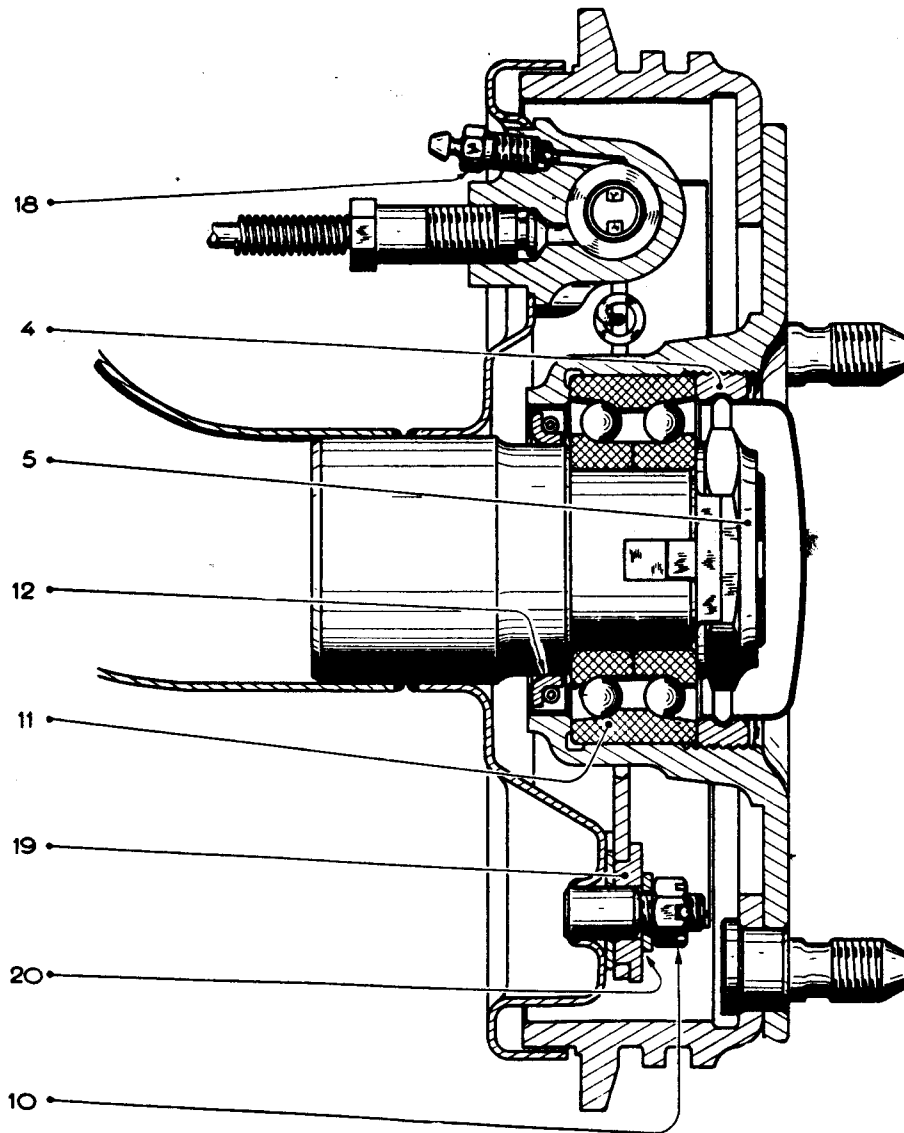

BRAKE BACKPLATE

Fig. 1 LEFT SIDE FRONT VIEW

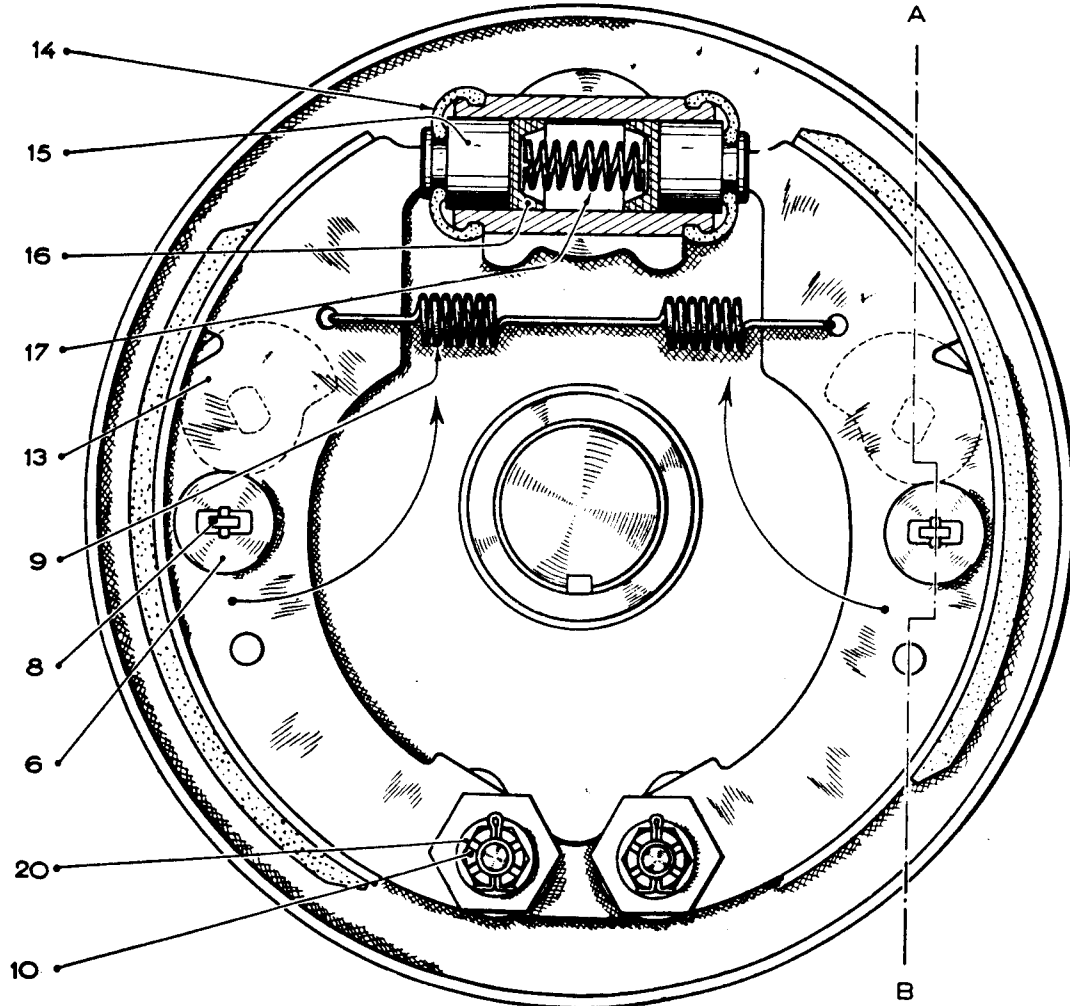
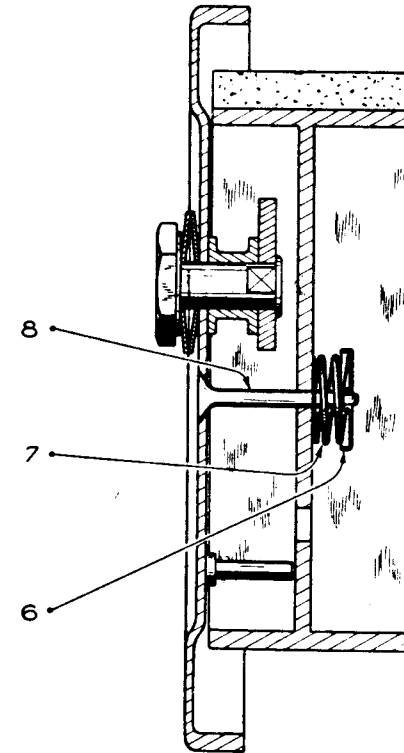
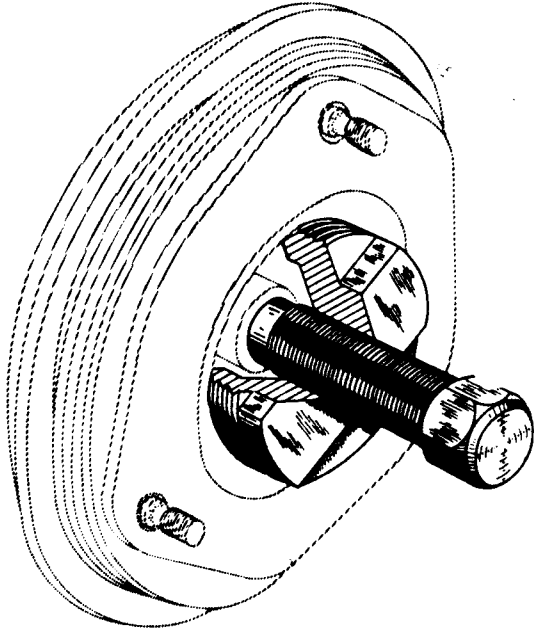

Fig. 2 SECTION A B



VARIOUS TOOLS

Fig 1 - UTILIZATION OF THE EXTRACTOR



EXTRACTOR Sold under No. 2003-VA

Fig 2 - UTILIZATION OF THE SPANNER ON REAR HUB

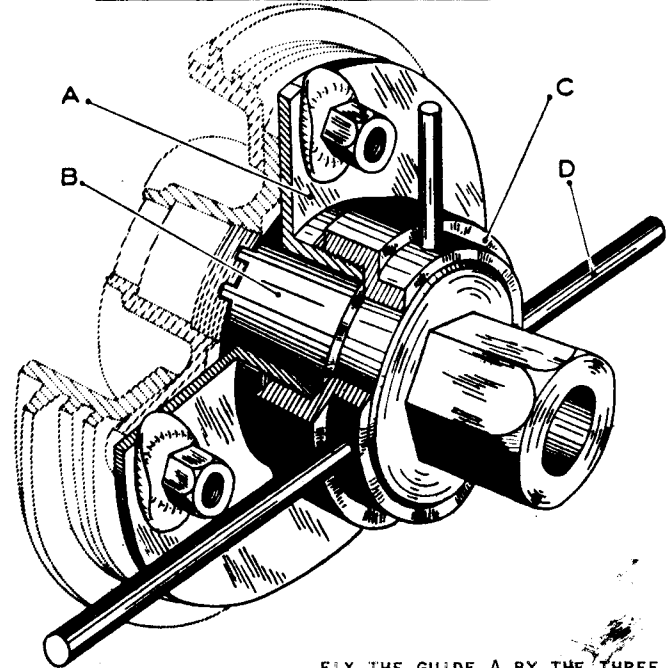

FIX THE GUIDE A BY THE THREE WHEEL NUTS. PLACE THE SPANNER B SCREW UP THE NUT C WITHOUT TIGHTENING. LOCK THE SPANNER B AND NUT C WITH THE AID OF TOMMY BAR D. UNSCREW HUB NUT COLLAR

Fig 3

UTILIZATION OF THE SPANNER ON FRONT HUB

PLACE THE SPANNER B
FIT THE SCREW E WITHOUT TIGHTENING
UNSCREW HUB NUT COLLAR NOW ON SCREW E.

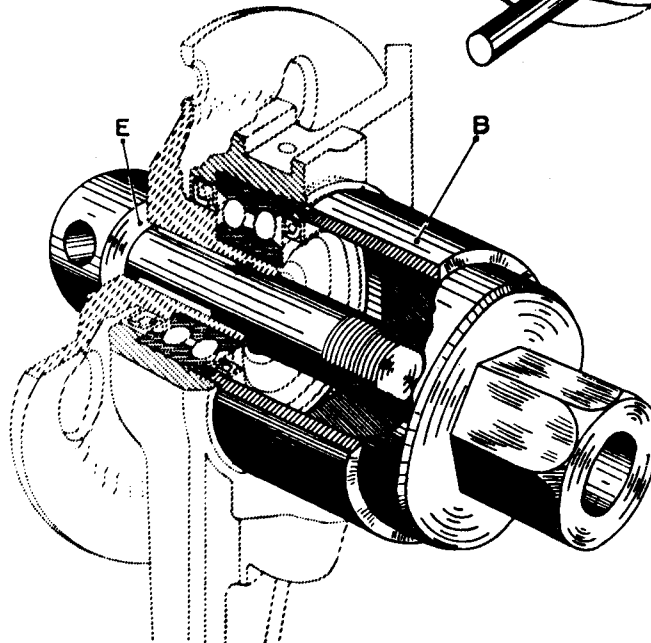

SPANNER Sold under No. 1811-VA

FLARING ADJUSTING CAMS OF BRAKE SHOES

Fig. 1 - UTILIZATION

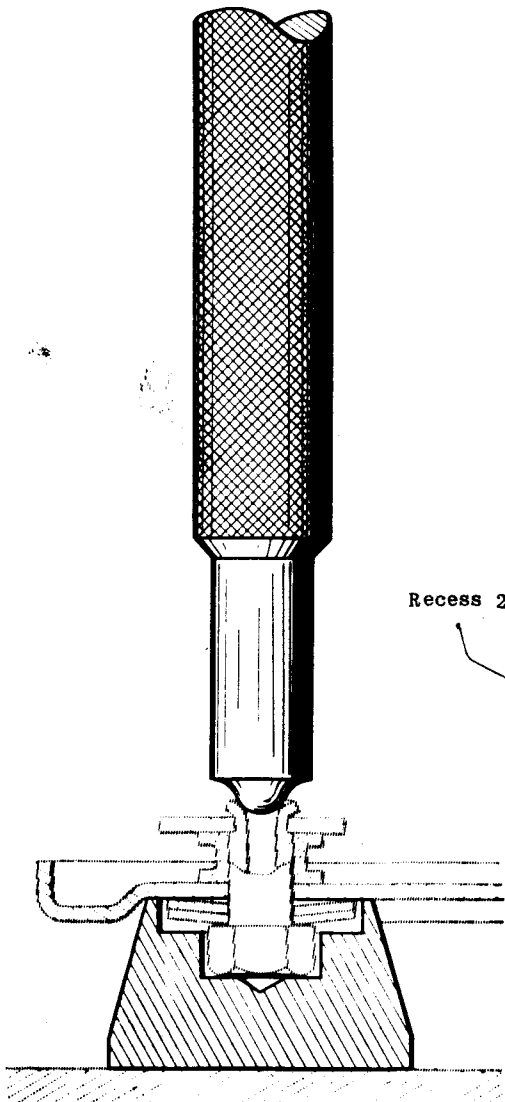

Fig. 2 - PUNCH MR. 3354-2

Not sold

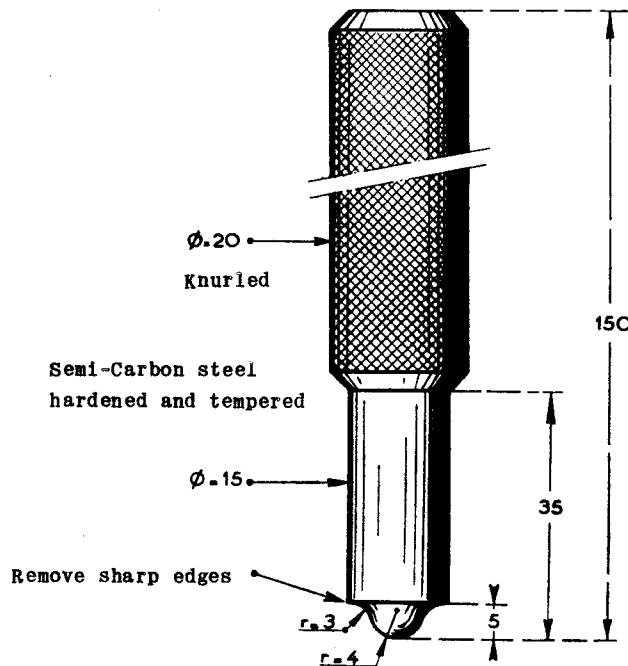

Fig. 3 - SOCKET MR. 3354-10

Not sold

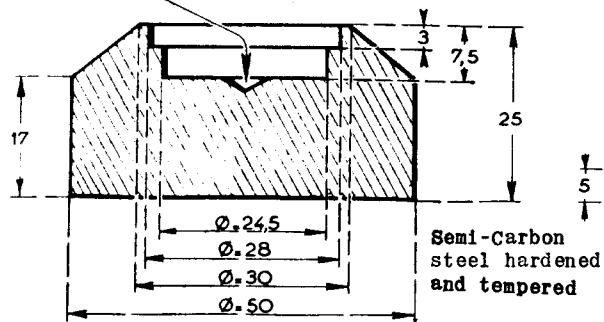

Fig. 4 - SOCKET MR. 3354-20

Not sold

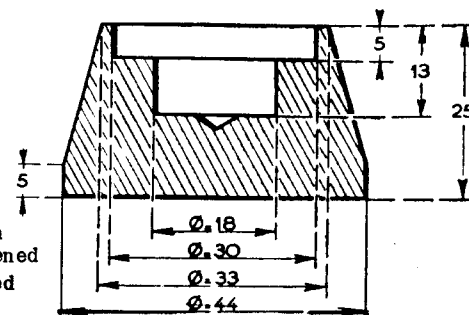

Fig. 1 - METHOD OF USING THE TOOLS

SECTION ON X.O.Y

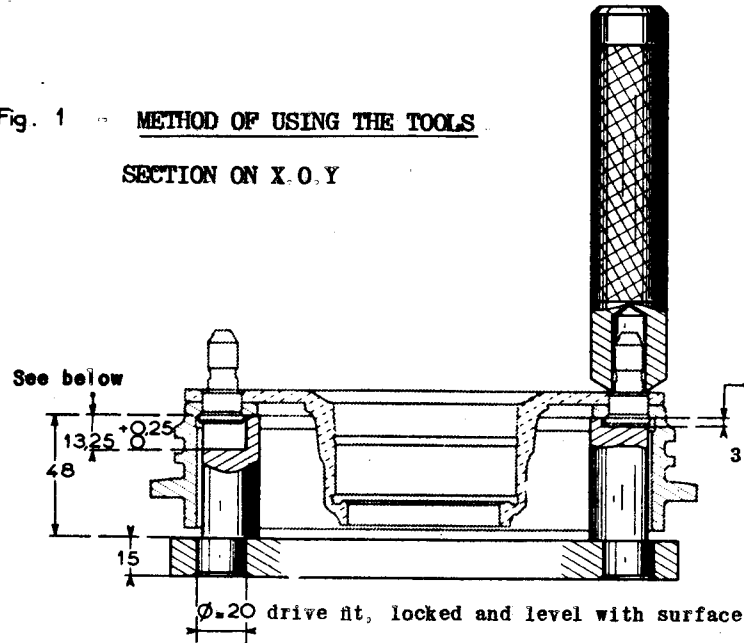

Fig. 2 - HOLLOW PUNCH MR. 3445-24

Not sold

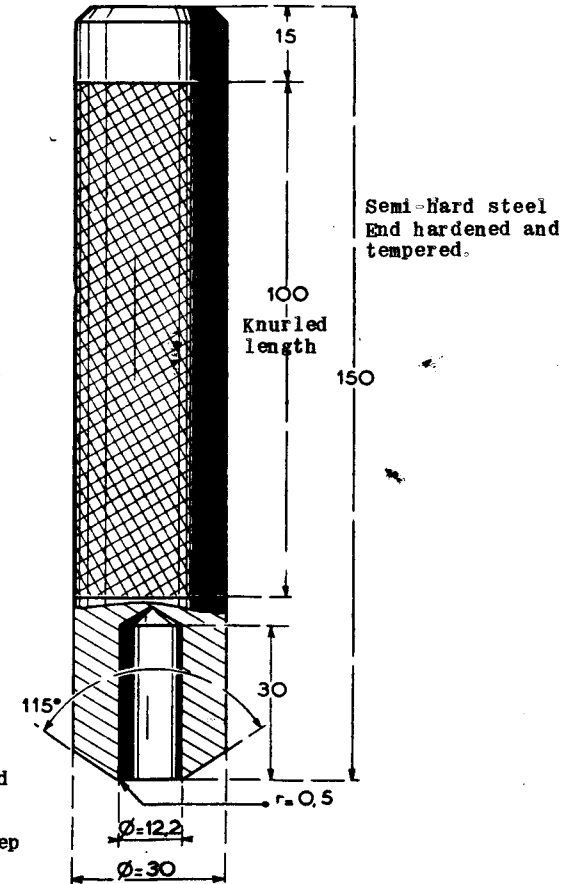
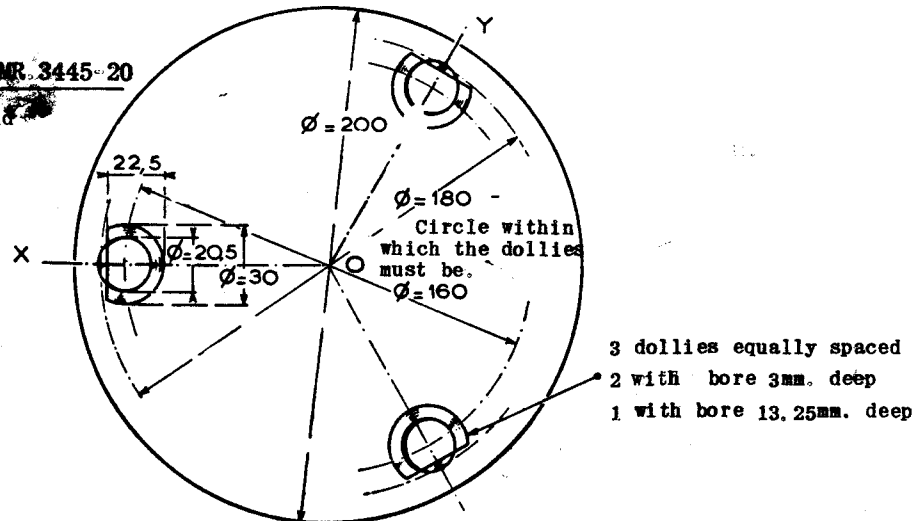
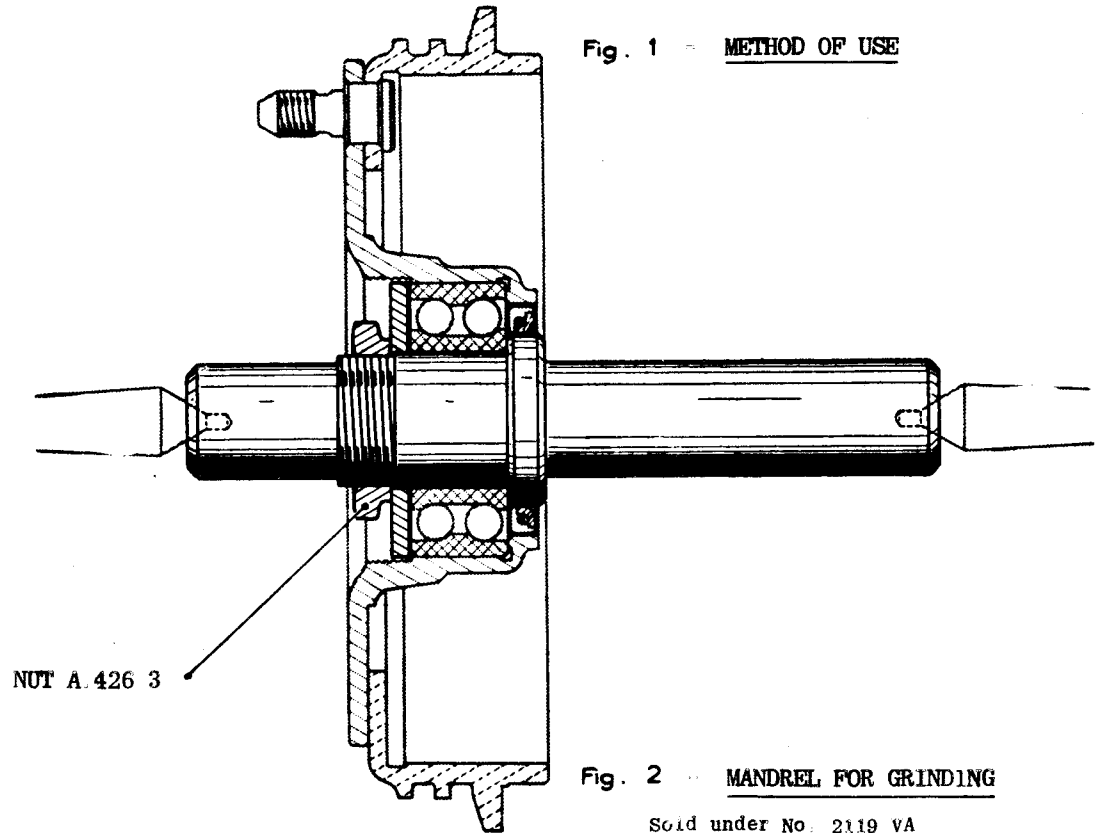

Fig. 3 - PLATE MR. 3445-20

Not sold



GRINDING THE BRAKE DRUM



NUT A. 426 3

Fig. 2 - MANDREL FOR GRINDING

Sold under No. 2119 VA

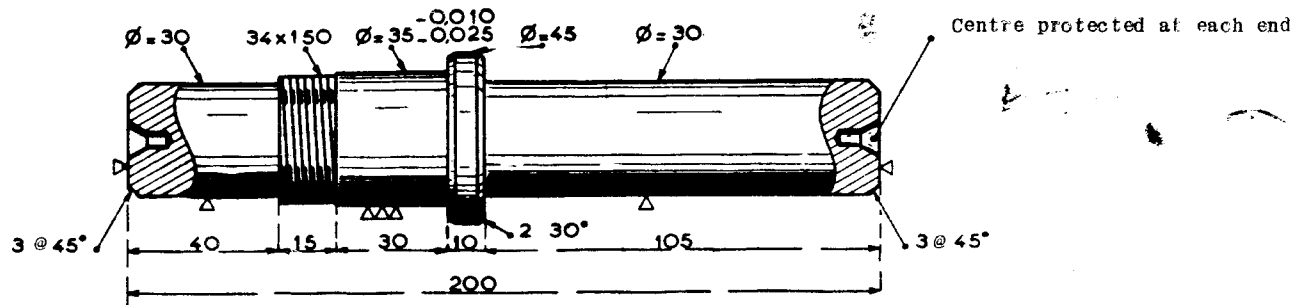
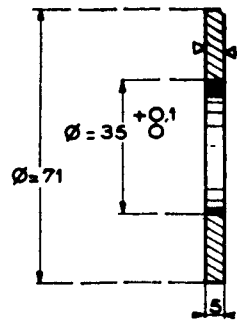

Centre protected at each end

— CHECKING CONCENTRICITY OF BRAKE LININGS —

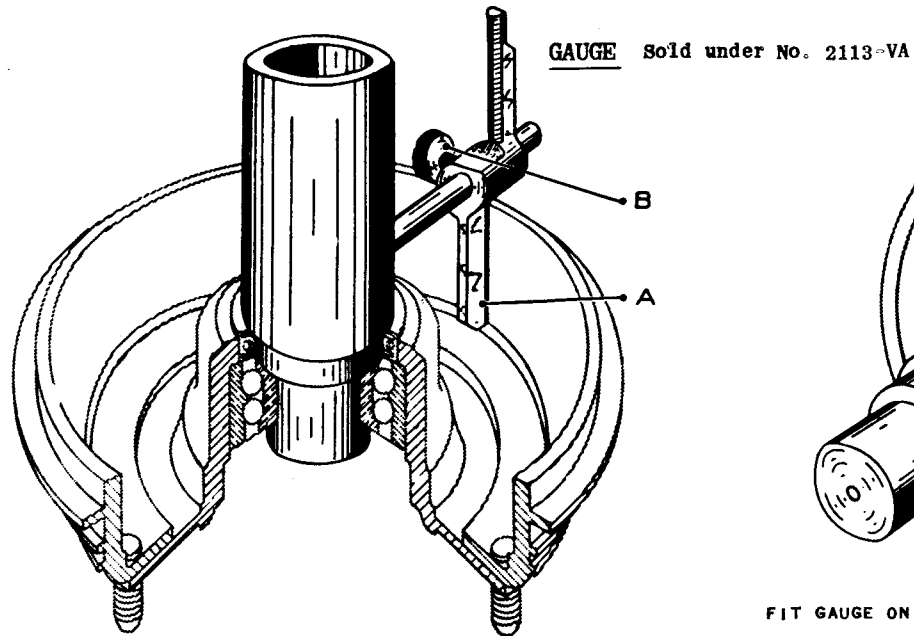
Fig 1 - REGISTERING DIAMETER OF DRUM

PLACE GAUGE IN POSITION IN THE BALLRACE. BRING INDICATOR A IN CONTACT WITH DRUM AND DESCRIBE A COMPLETE CIRCLE. LOCK INDICATOR AT SET POSITION WITH THUMB SCREW B.

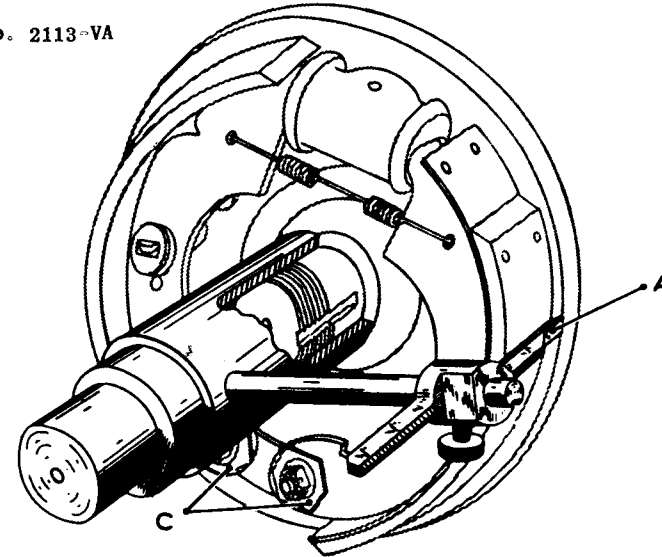
Fig. 2 - CHECKING CONCENTRICITY OF LININGS

FIT GAUGE ON STUB
 PLACE THE INDICATOR A, AS SET PREVIOUSLY ON THE LININGS, INDICATOR MUST REMAIN IN CONTACT THROUGHOUT CIRCUMFERENCE (IN ORDER TO OBTAIN THIS RESULT ADJUST LININGS BY ECCENTRIC BUSHES C AND ADJUSTING CAMS AT REAR OF BACKPLATE, NOT SHOWN). REMOVE BURRS ON BRAKE LININGS WITH A RASP. AFTER CHECK RELEASE CAMS TO ALLOW FITTING OF DRUM.

FOR FINAL ADJUSTMENT OF CAMS SEE OPERATION 49 PARAGRAPHS 9 TO 11.

— REAR AXLE —

— CHECKING ARM —

Fig. 1 - UTILIZATION OF ASSEMBLY

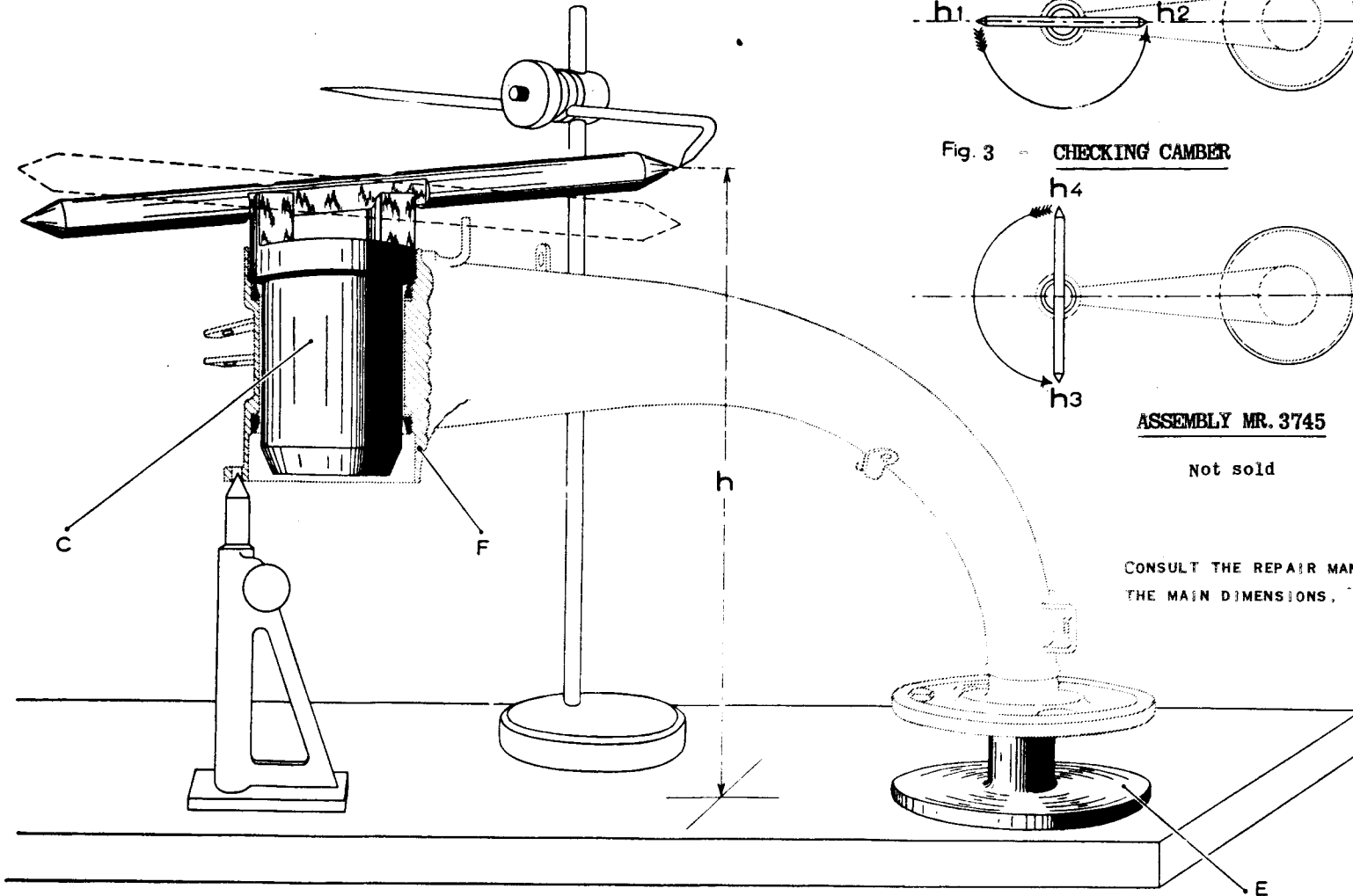

Fig. 2 - CHECKING ALIGNMENT

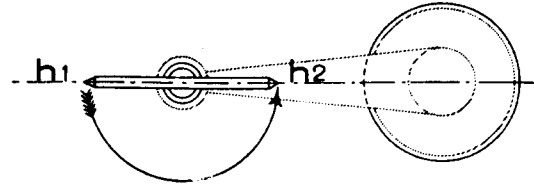
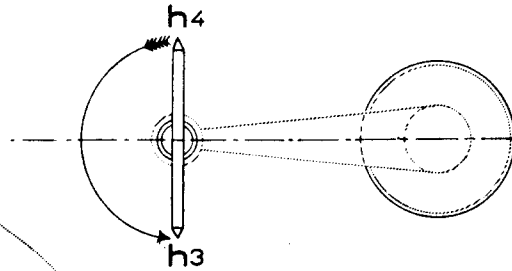

Fig. 3 - CHECKING CAMBER



ASSEMBLY MR. 3745

Not sold

CONSULT THE REPAIR MANUAL FOR
THE MAIN DIMENSIONS.

— SECTION OF MASTER CYLINDER —

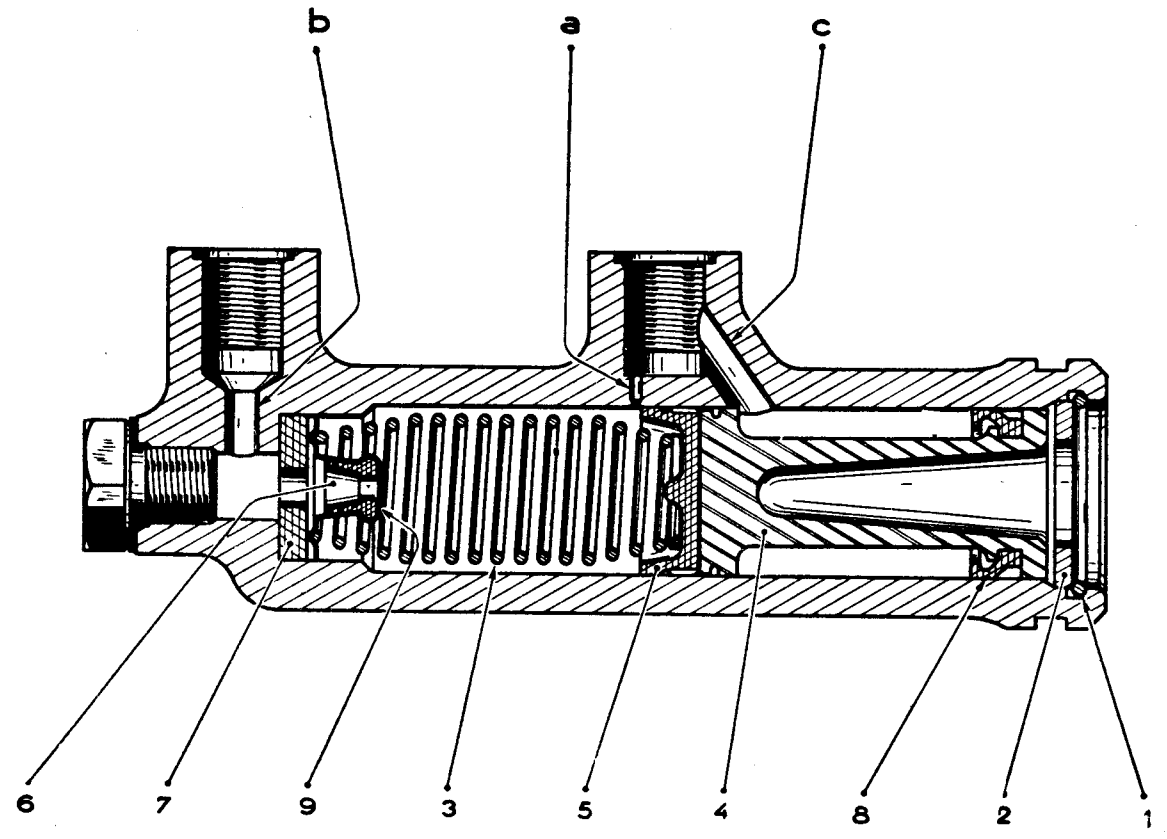

SUSPENSION UNIT

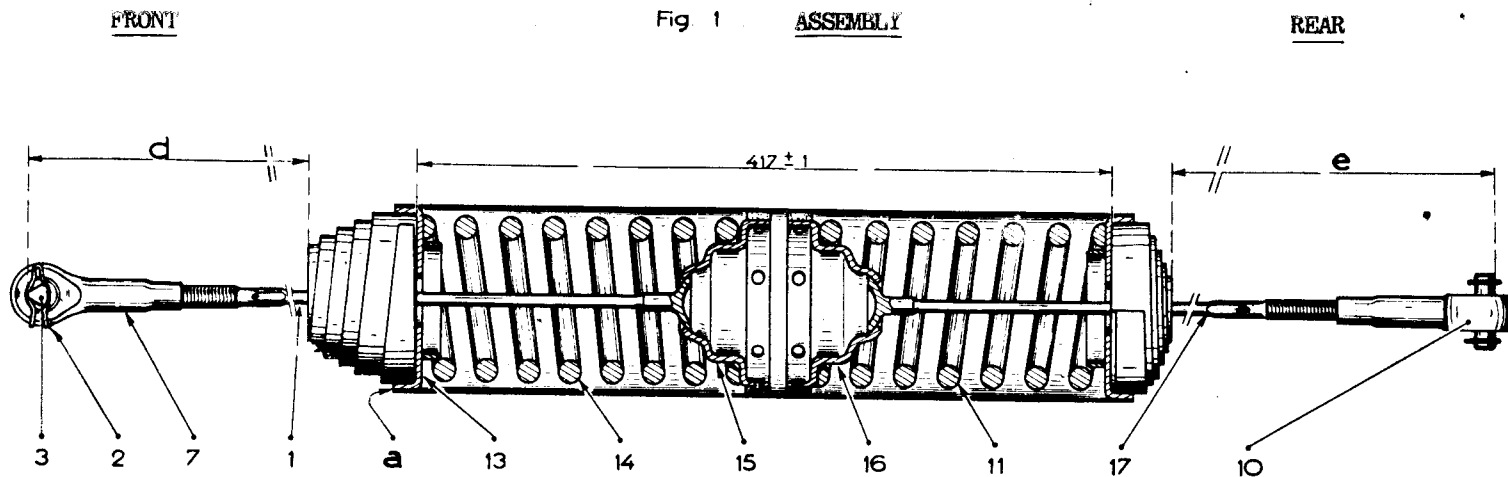
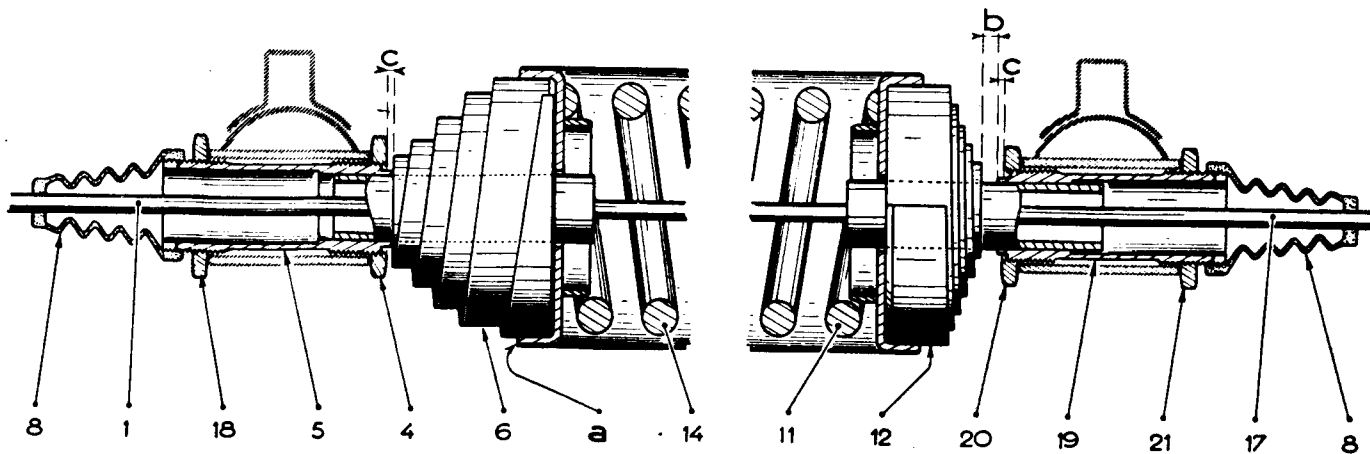
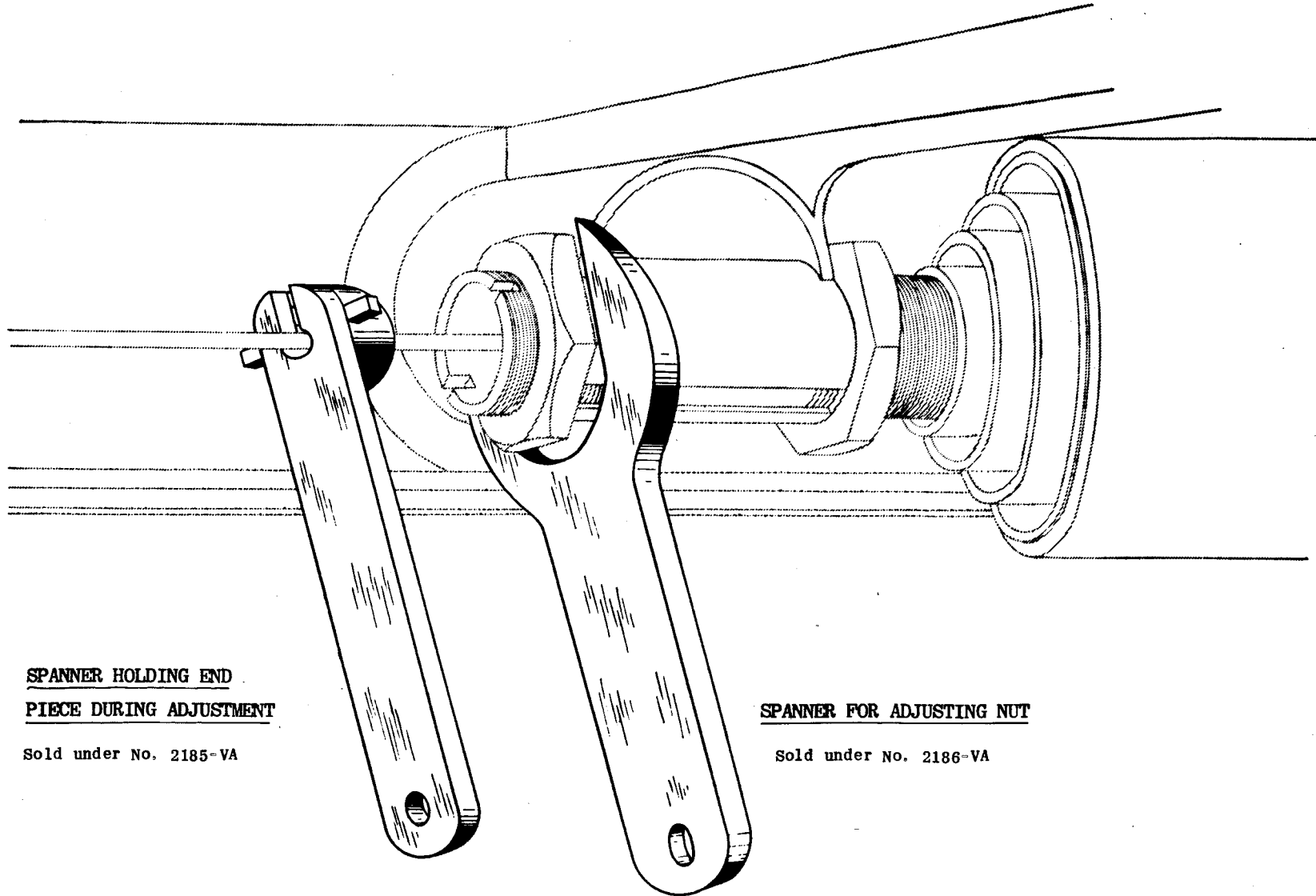

Fig 2 DETAILS OF END PIECES



— ADJUSTING POSITION OF SUSPENSION UNIT —

SPANNER HOLDING END
PIECE DURING ADJUSTMENT

Sold under No. 2185-VA

SPANNER FOR ADJUSTING NUT

Sold under No. 2186-VA

— SUSPENSION —

— INERTIA DAMPER —

NOTE: ON THE CAR THE PLUG (1) IS FOUND AT THE TOP

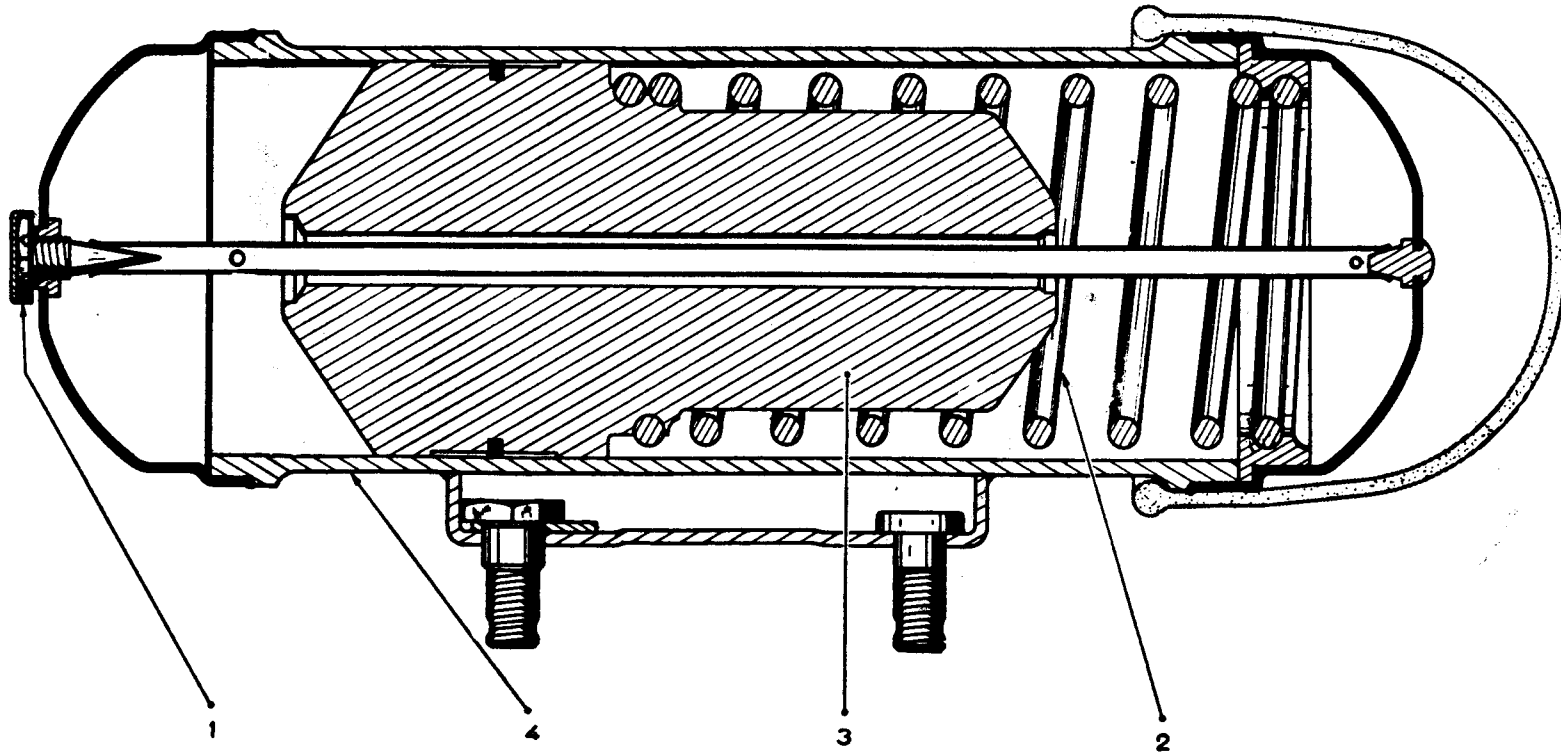

ELECTRICAL

WINDSCREEN WIPER

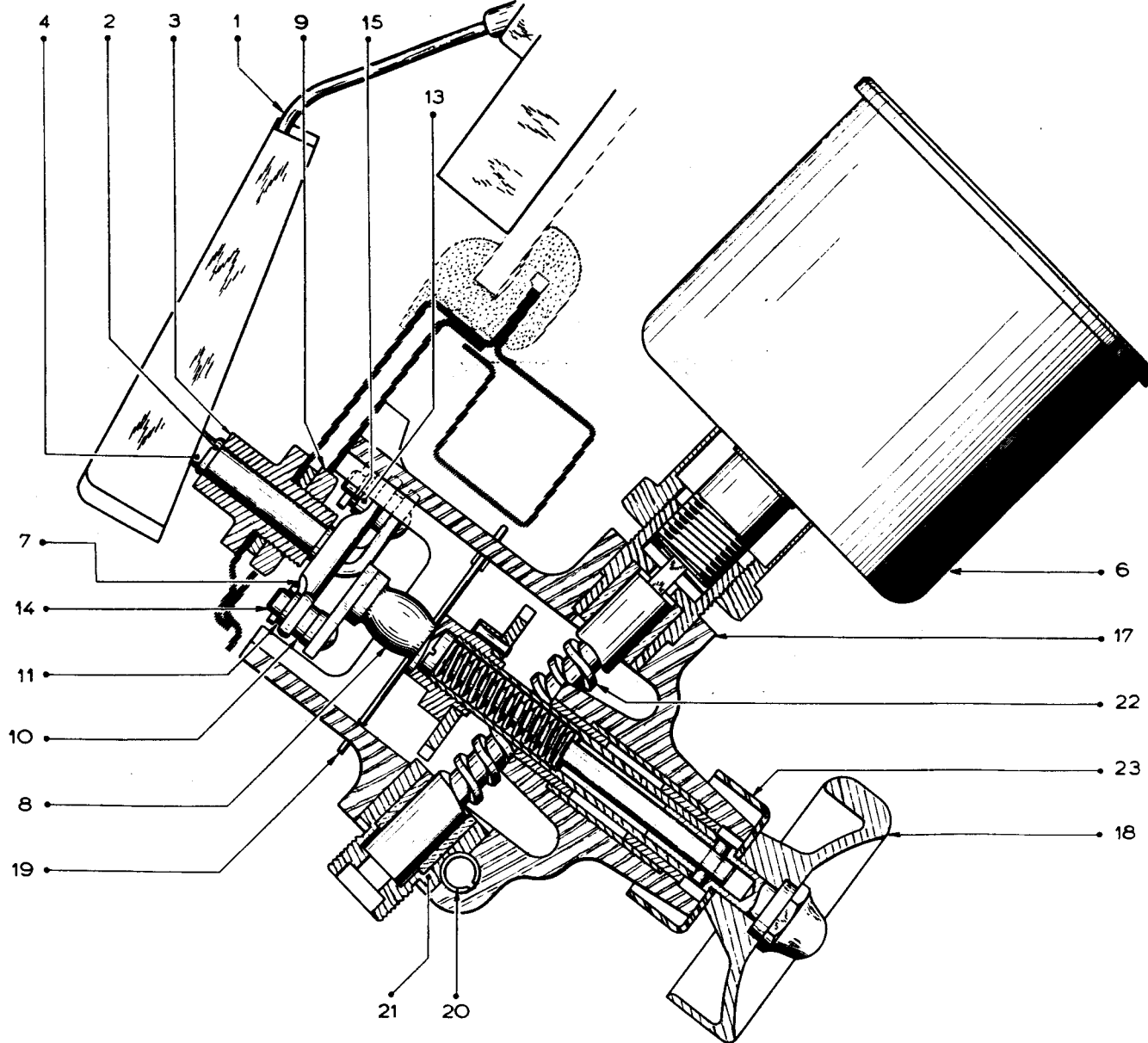

— ELECTRICAL —

— DYNAMO —

— FIXING BY 3 SCREWS —

LONGITUDINAL SECTION

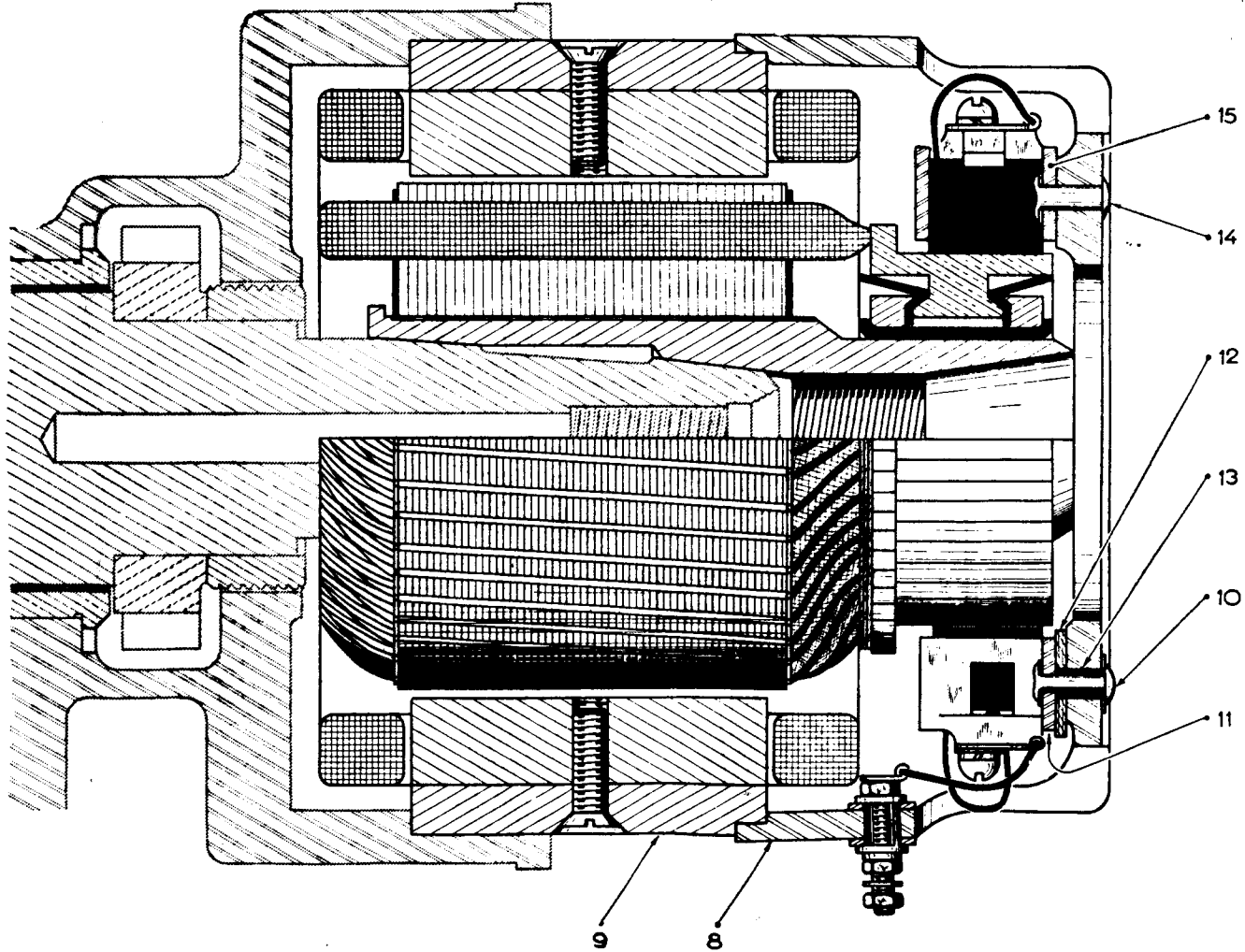

— ELECTRICAL —

— DYNAMO —

— FIXING BY 3 SCREWS —

END VIEWS

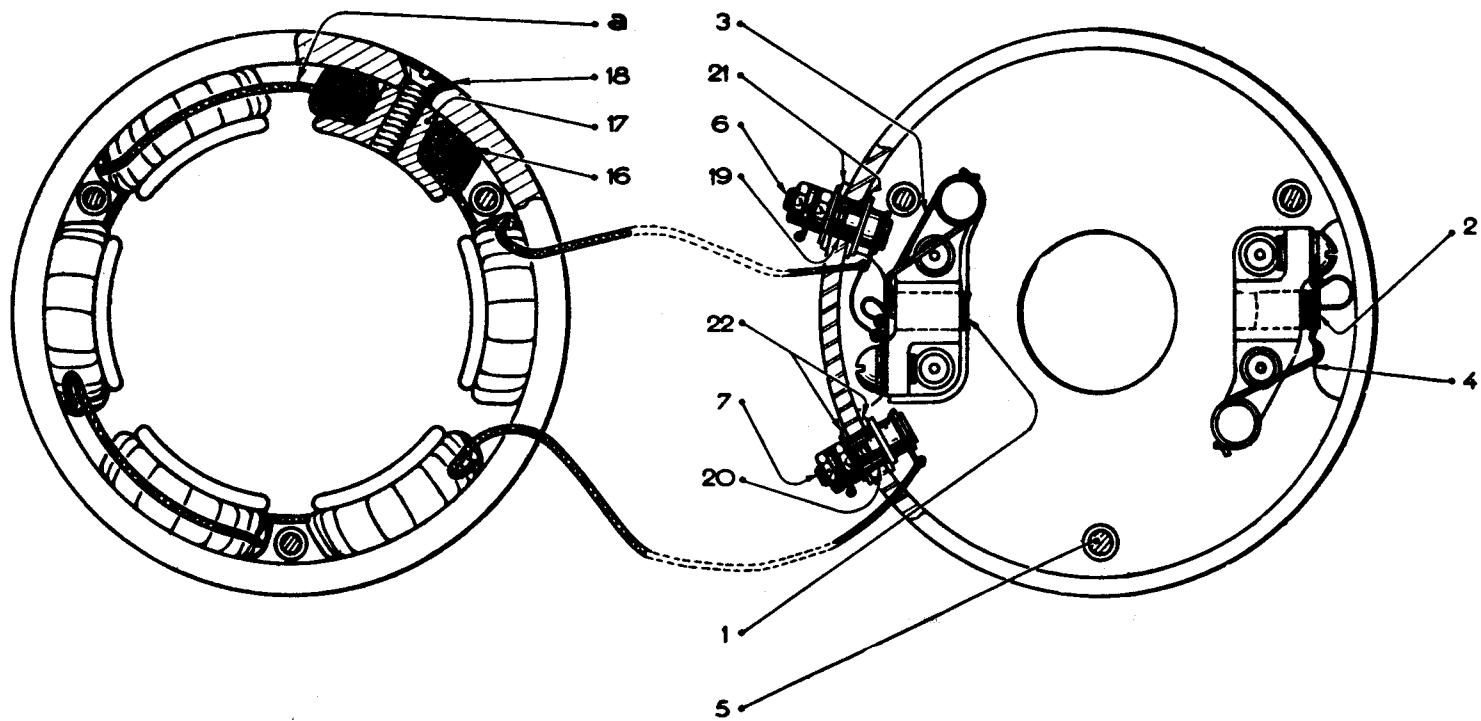

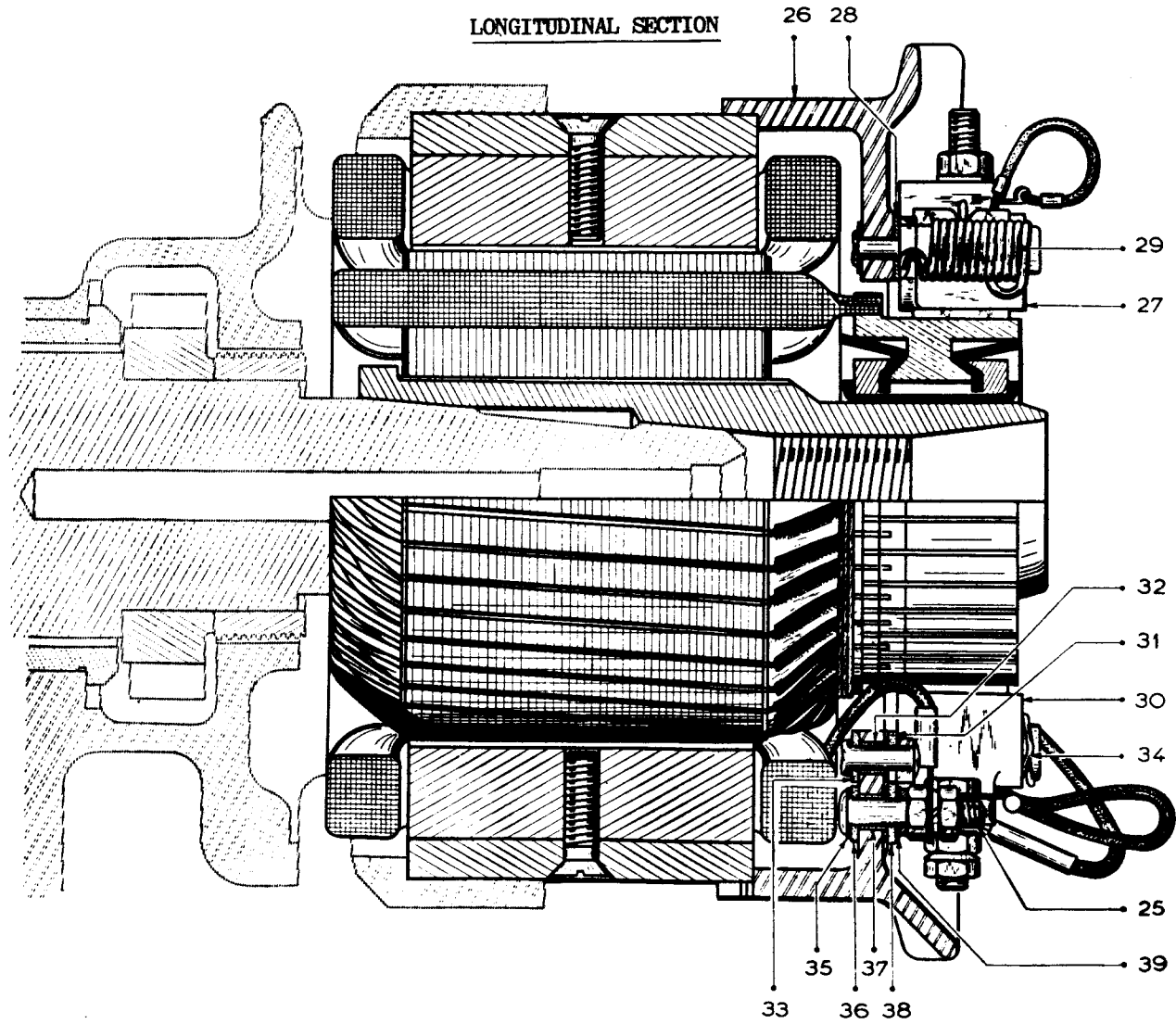

ELECTRICALDYNAMOFIXING BY 2 SCREWSEND VIEWS

Fig. 1 - EXTRACTOR FOR BATTERY TERMINAL



EXTRACTOR

Sold under No. 2200-T

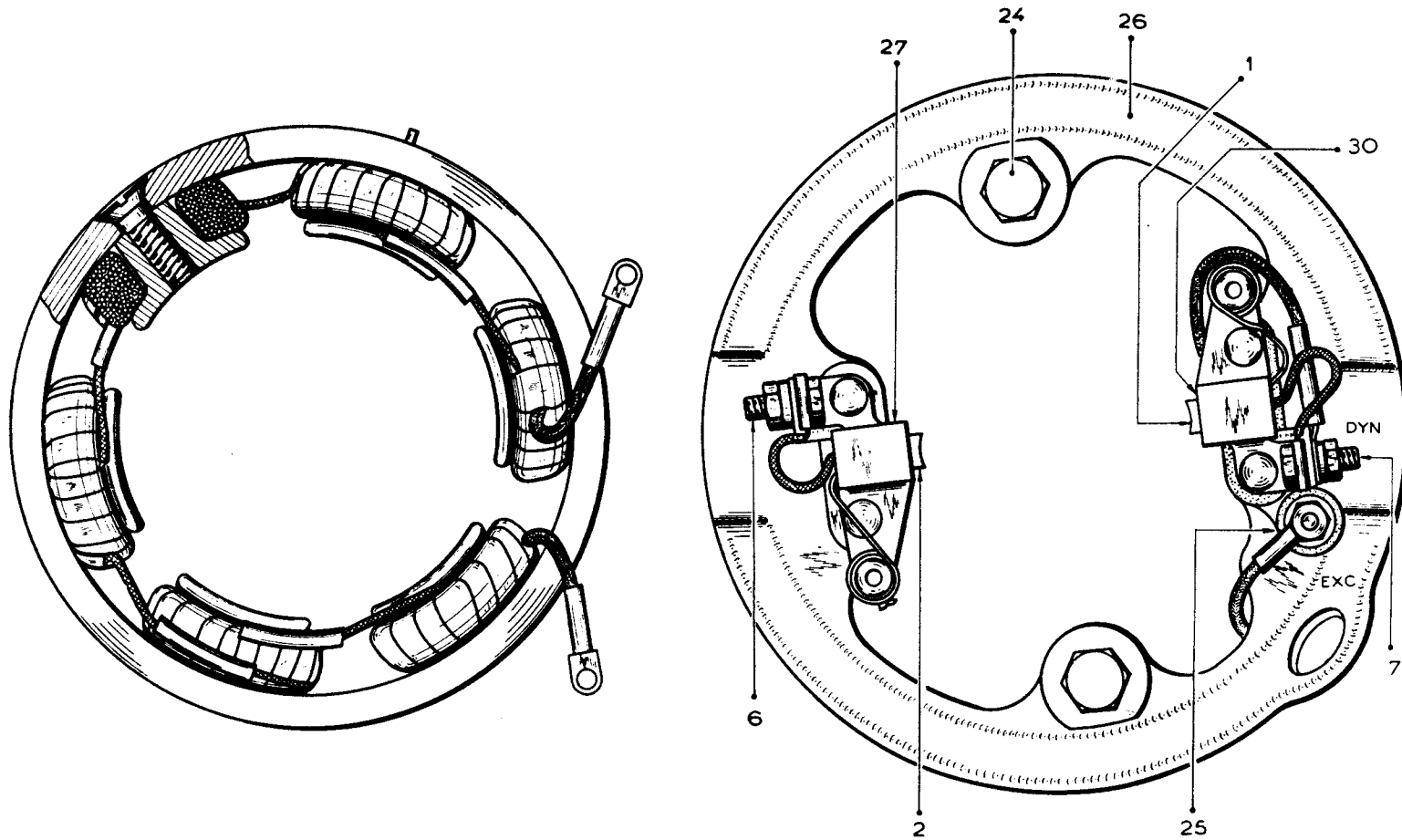
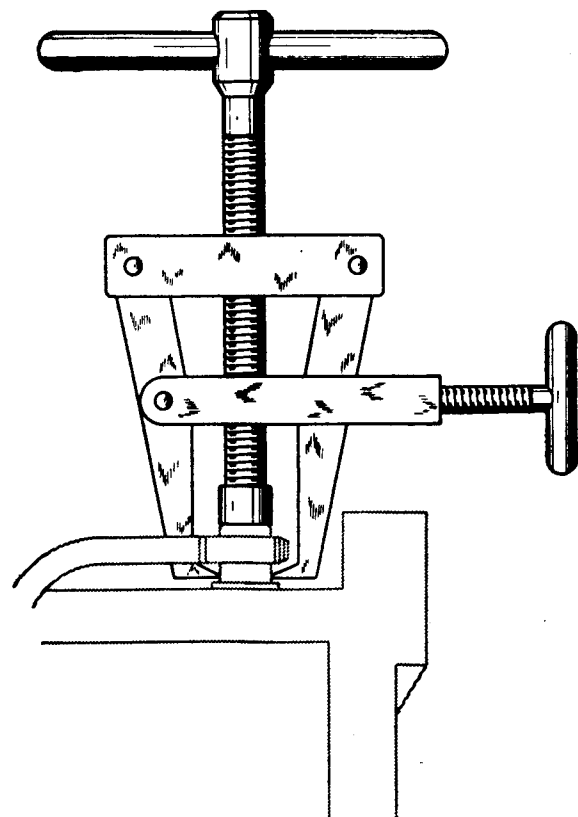
Fig. 2 - REMOVING ARMATURE

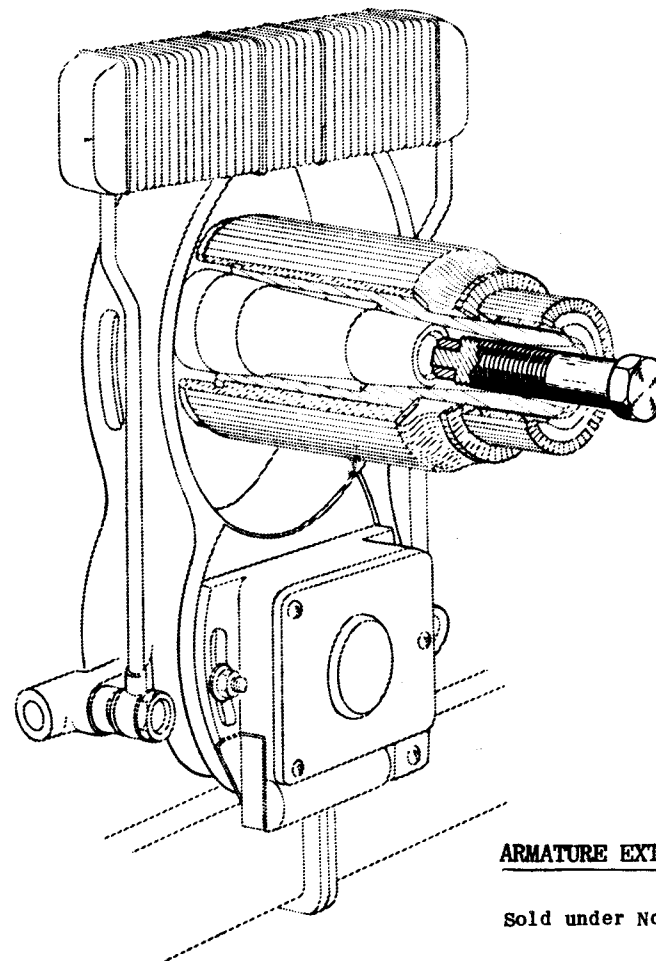

ARMATURE EXTRACTOR SCREW

Sold under No. 2205-VA

FITTING THE COILS AND POLE PIECES

Fig. 1 - POSITIONING THE COILS

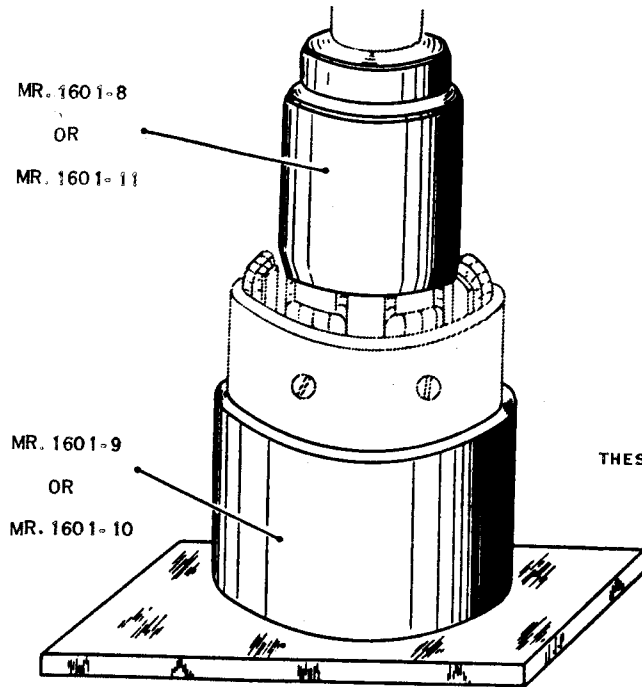

THESE TOOLS ARE NOT SOLD

Fig. 2 - FITTING THE POLE PIECES

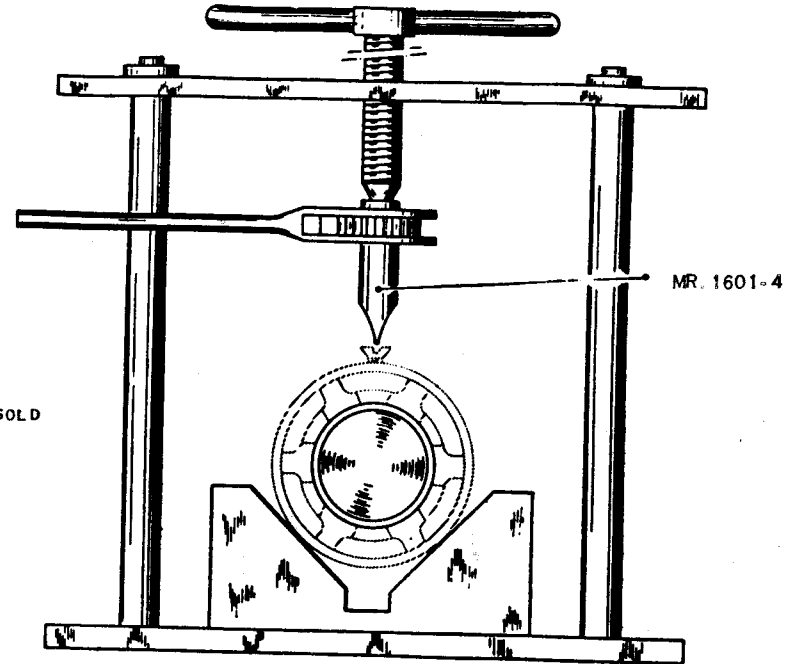

FOR THE STARTER

MANDREL MR. 1601-11 DUCELLIER COLLAR MR. 1601-10
 MANDREL MR. 1601-12 PARIS-RHONE

FOR THE DYNAMO

MANDREL MR. 1601-8 COLLAR MR. 1601-9 SCREWDRIVER MR. 1601-4

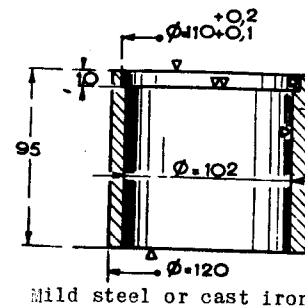
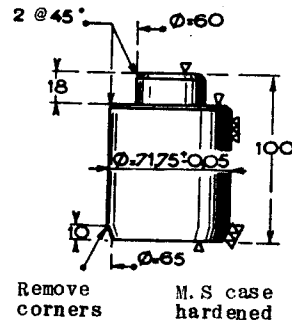
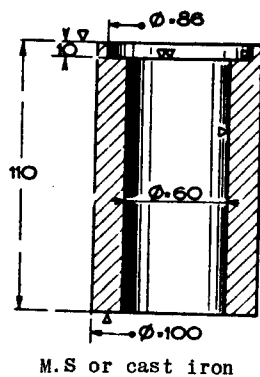
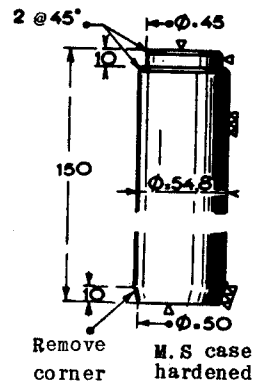

Hexagon to suit ratchet spanner

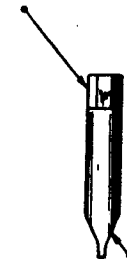

Treated portion

— TESTING ON THE BENCH —

SUPPORT FOR DYNAMO ON TEST

Sold under No. 2207-VA

THIS SUPPORT HOLDS AND POSITIONS THE BODY AND ARMATURE OF THE DYNAMO FOR INSPECTION.

THE BRUSH HOLDER COVER IS HELD BY THE 3 SCREWS FIXING THE DYNAMO TO THE ENGINE.

THE SUPPORT IS USED ON THE USUAL TEST BENCH USED BY ELECTRICAL REPAIRERS.

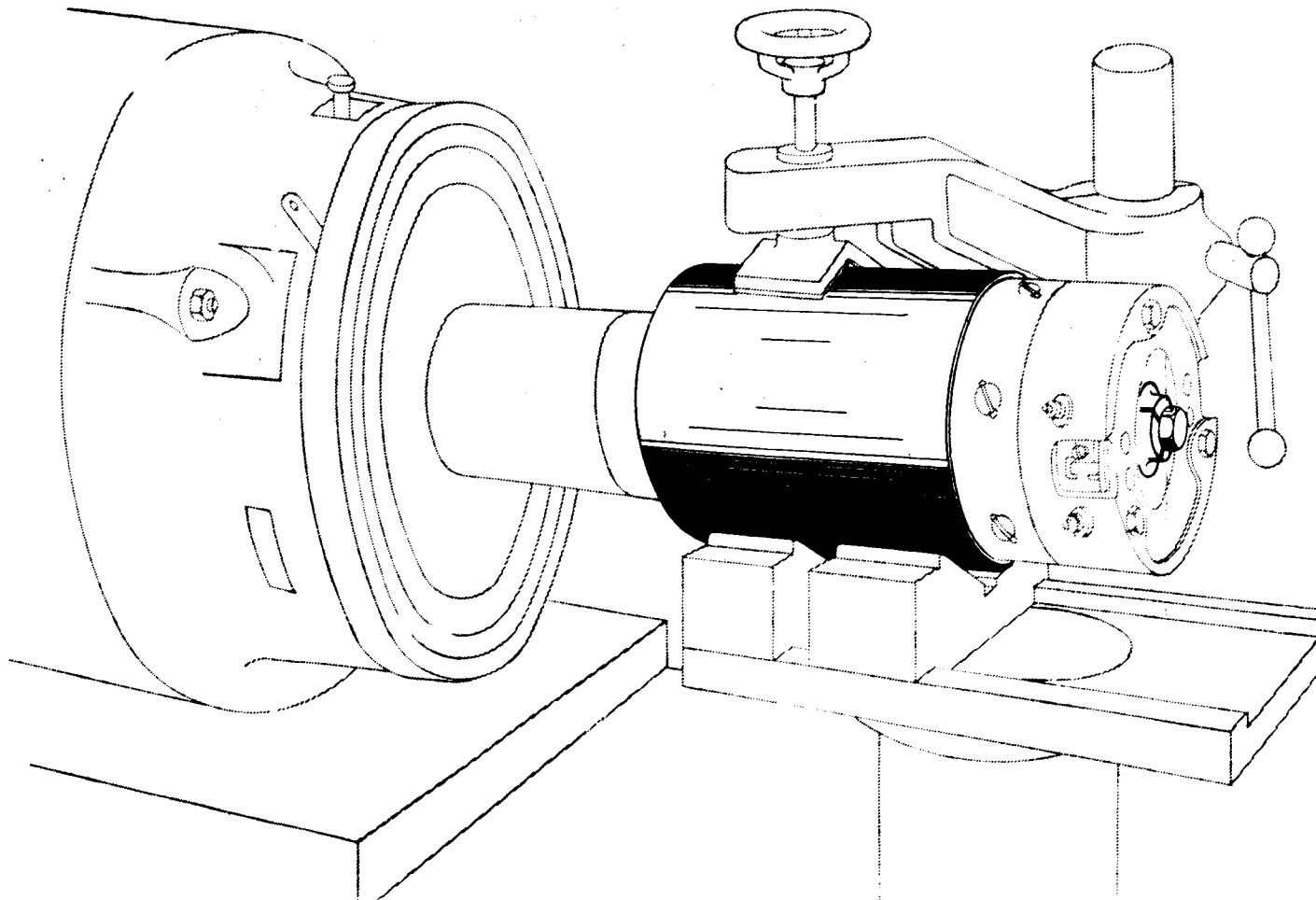

REGULATORS - DIAGRAMS

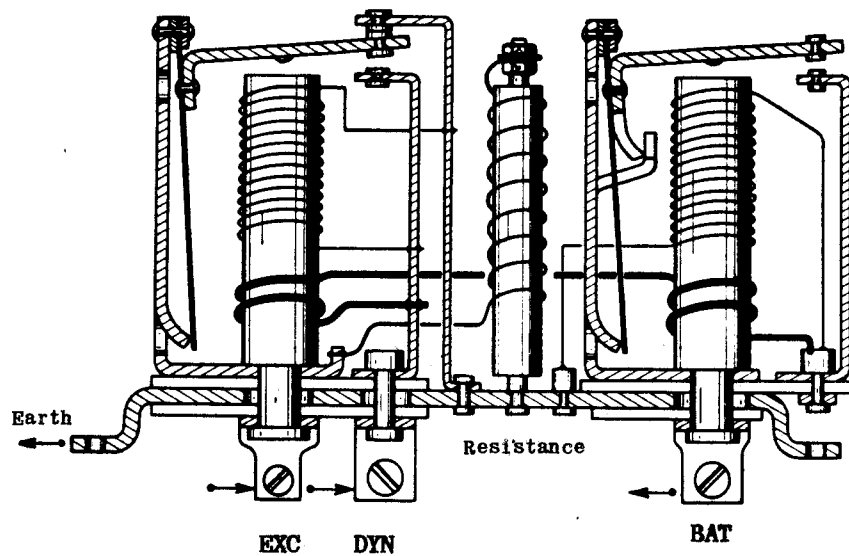
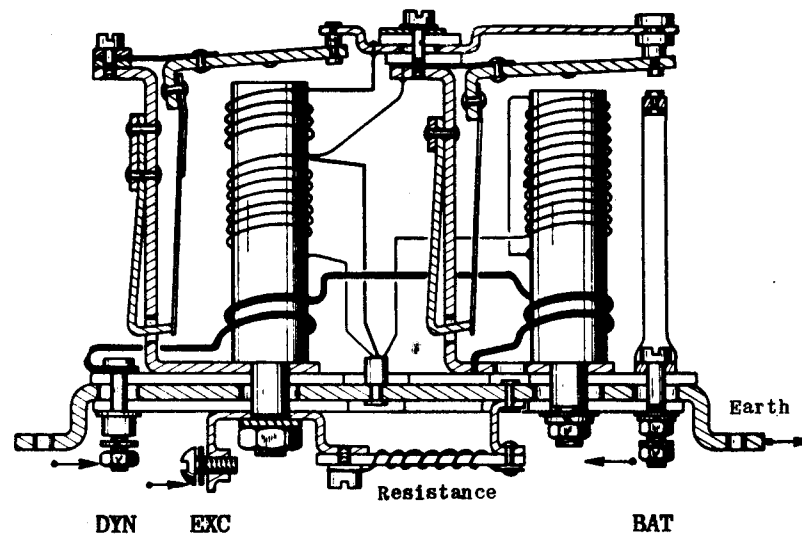
Fig. 1 - DUCELLIER REGULATORTWO STAGE REGULATIONFig. 2 - S.N.A. REGULATORSINGLE STAGE REGULATION

REGULATOR TEST

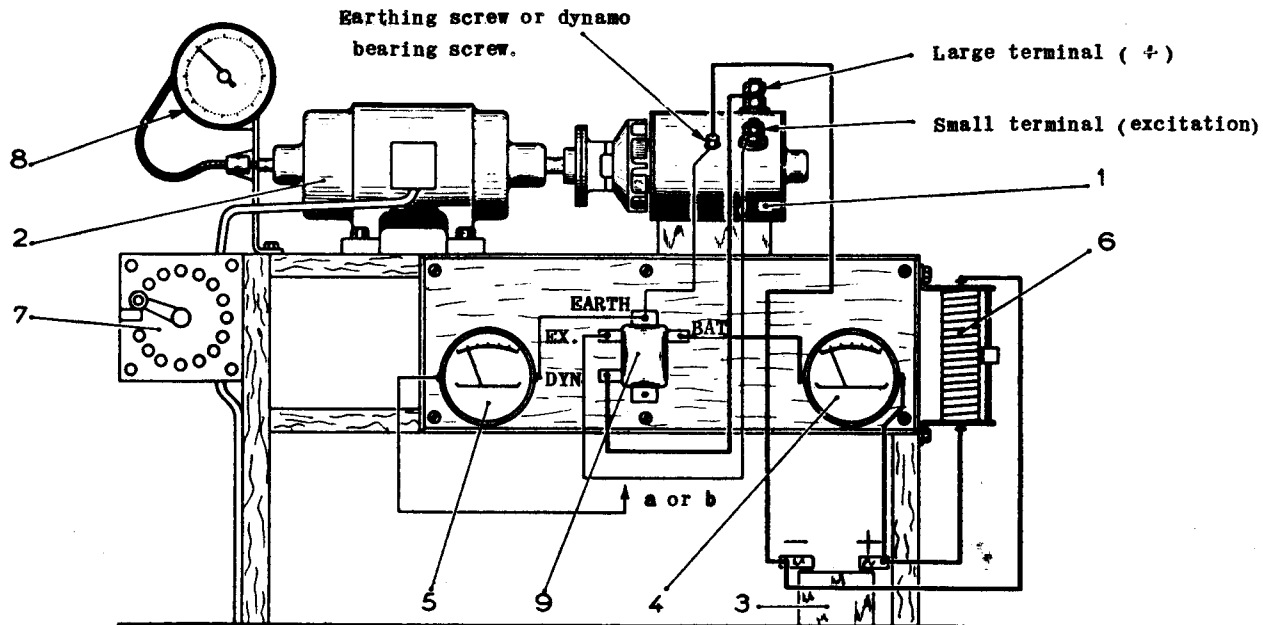

1. CITROEN 6V DYNAMO WITH VOLTAGE REGULATION FOR DUCELLIER REGULATOR (FLAT BASE) SP.39.
2. 2CV ENGINE DRIVING THE DYNAMO AT SPEEDS VARYING FROM 0 TO 4000 R.P.M.
3. 6V BATTERY (PREFERABLY MOTO 15/24 A/HR. TO GIVE RAPID VOLTAGE VARIATION AT THE TERMINALS).
4. AMMETER IN CHARGING CIRCUIT.
5. VOLTMETER a) CONNECTED BETWEEN THE DYN TERMINAL ON THE REGULATOR AND EARTH TO RECORD THE VOLTAGES AT MAKING AND BREAKING.
b) CONNECTED BETWEEN THE BAT TERMINAL ON THE REGULATOR AND EARTH TO CHECK THE REGULATION.

6. VARIABLE RESISTANCE 0.2 TO 8 OHMS.
7. MOTOR RHEOSTAT.
8. TACHOMETER.
9. REGULATOR UNDER TEST (EARTHING SHOULD BE ENSURED BY A CABLE BETWEEN THE DYNAMO AND THE REGULATOR).

VERY IMPORTANT: THE CABLES MUST BE OF THE SAME CAPACITY AND LENGTH AS THOSE ON THE CAR, IN PARTICULAR THE RESISTANCE OF THE FEED REGULATOR-BATTERY MUST BE 0.03 OHM.

ELECTRICAL

WIRING DIAGRAM

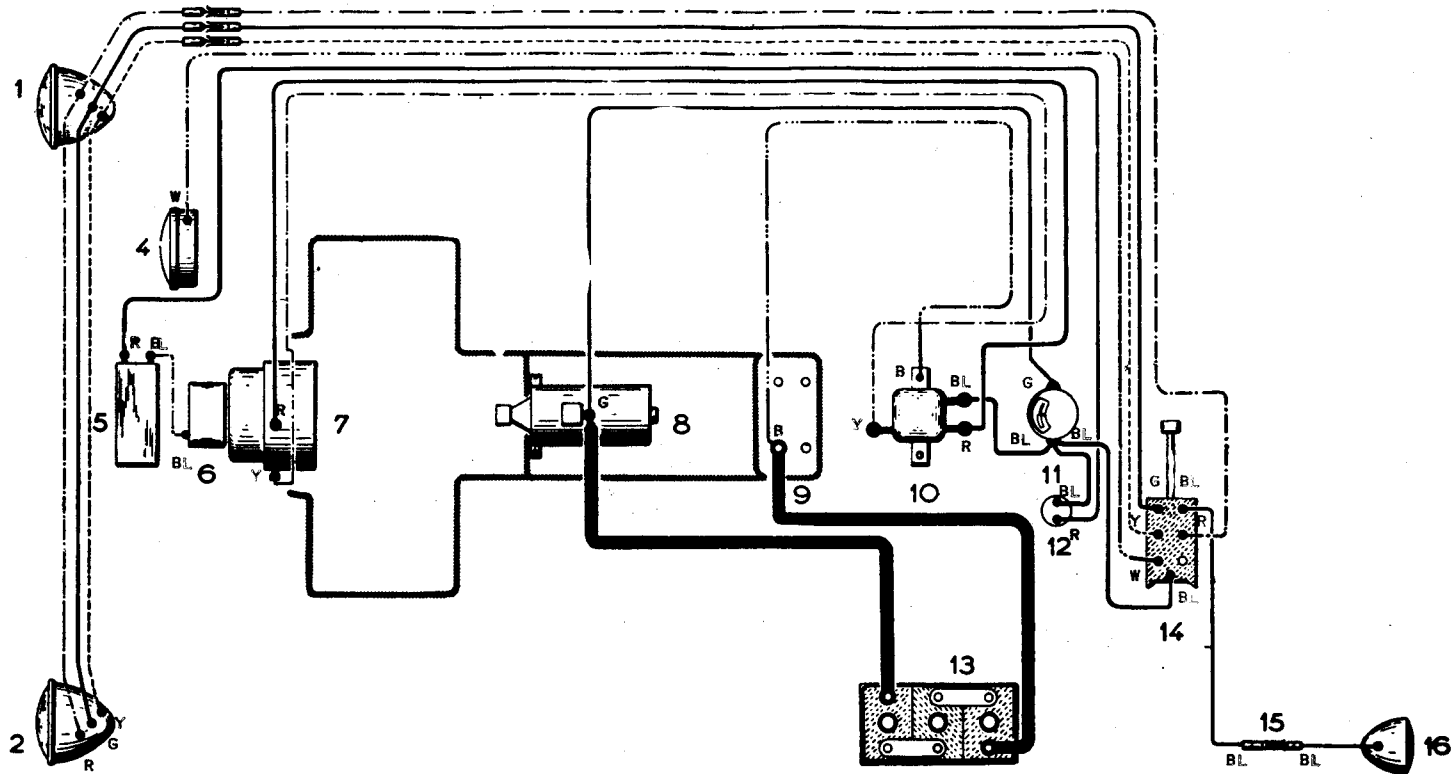

- 1** HEADLAMP R. H.
2 HEADLAMP L. H.
3 PLUG AND SOCKET CONNECTION FOR HEADLAMP.
4 HORN
5 COIL
6 CONTACT BREAKER
7 DYNAMO
8 STARTER

- 9** EARTHING SCREW ON GEARBOX
10 REGULATOR
11 AMMETER
12 IGNITION SWITCH
13 BATTERY 6V. 60 A/HR.
14 LIGHTING AND HORN SWITCH
15 PLUG AND SOCKET CONNECTION FOR REAR LAMP
16 REAR LAMP

COLOUR CODE (BRAIDING)

- W .. WHITE
 BL .. BLUE
 Y .. YELLOW
 B .. BLACK
 R .. RED
 G .. GREEN

— PARIS-RHONE STARTER —

LONGITUDINAL SECTION

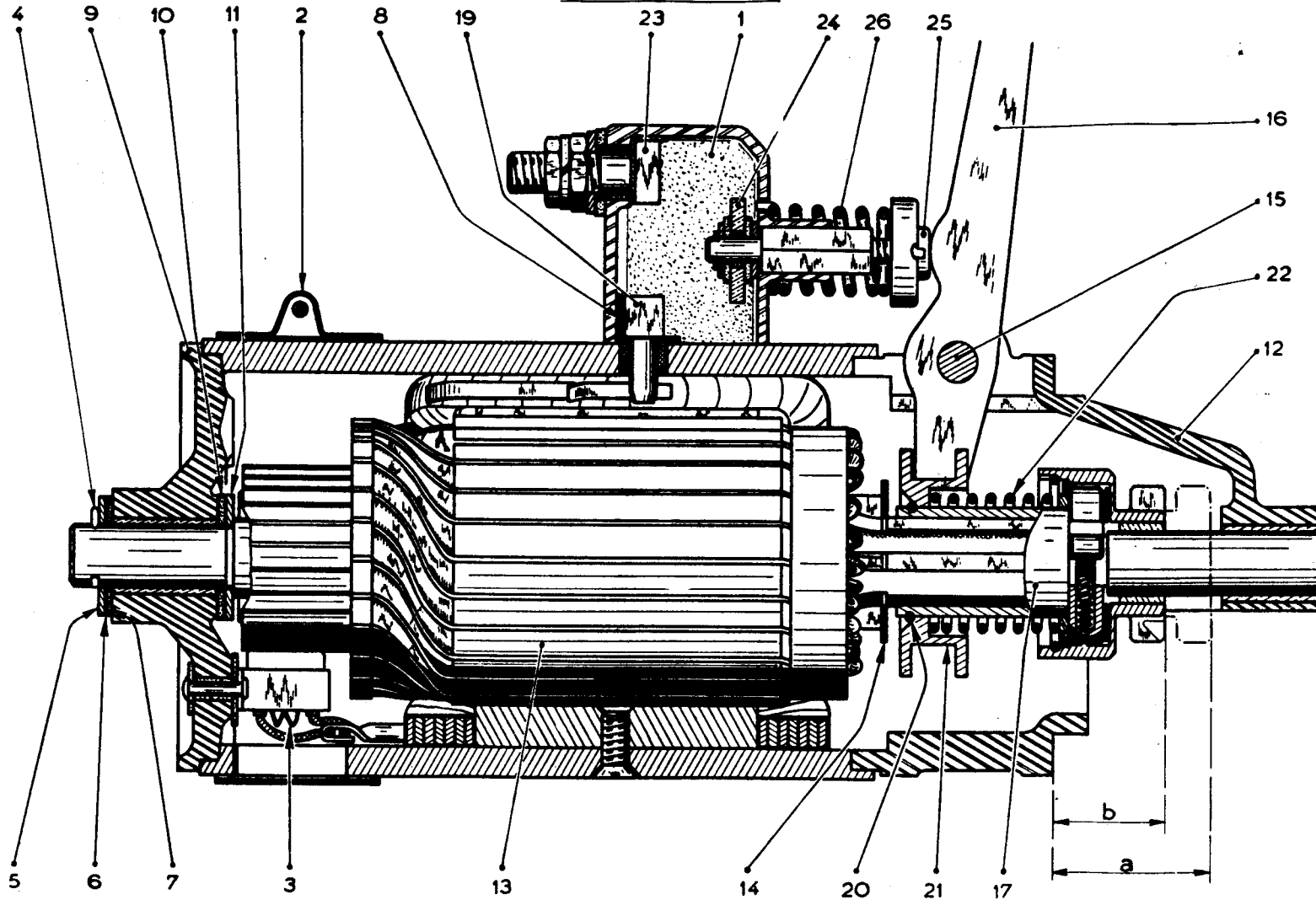

DUCELLIER STARTER

LONGITUDINAL SECTION

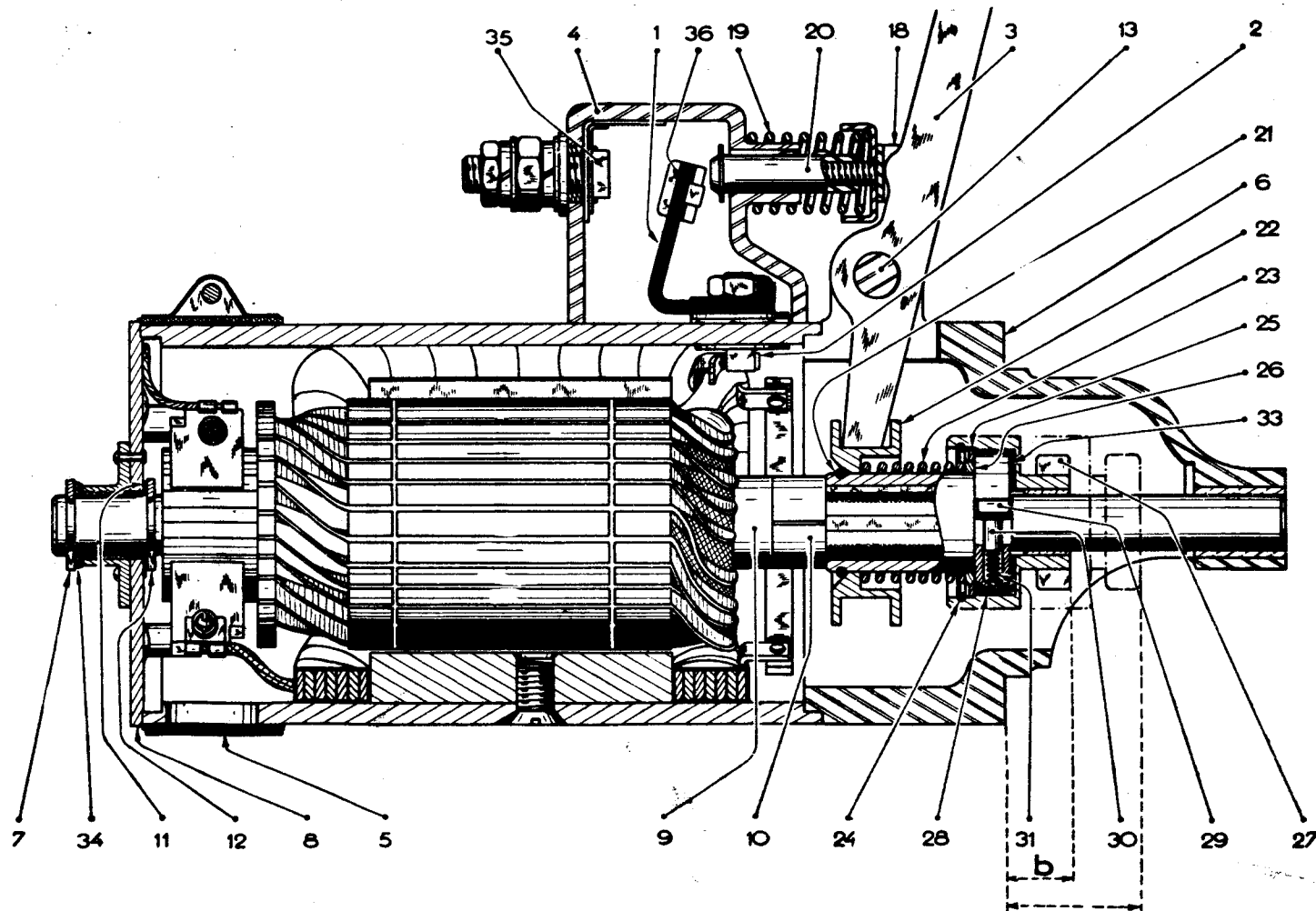

DUCELLIER STARTER

Fig 1 - INDUCTION COIL ASSEMBLY

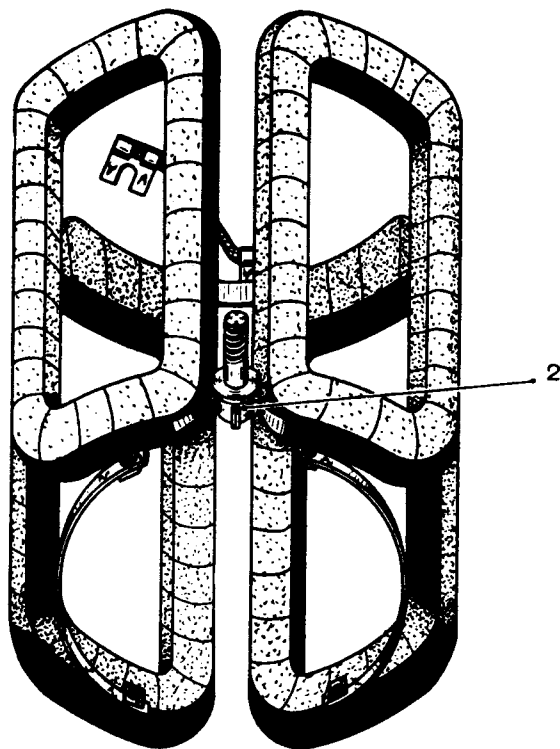

Fig. 2 - BRUSH ASSEMBLY

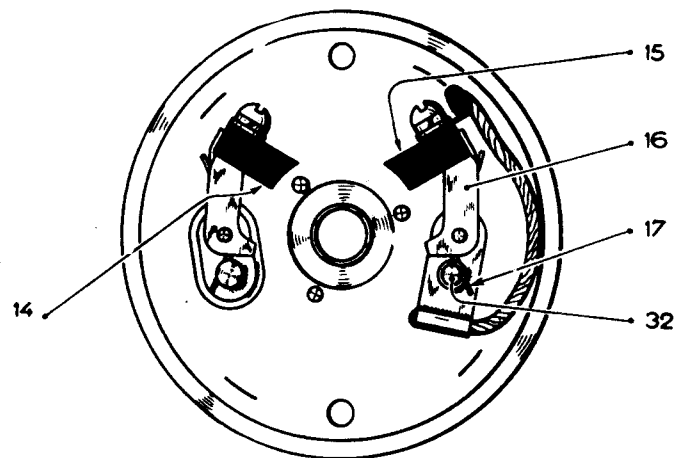

Fig. 1 - INDUCTION COIL ASSEMBLY

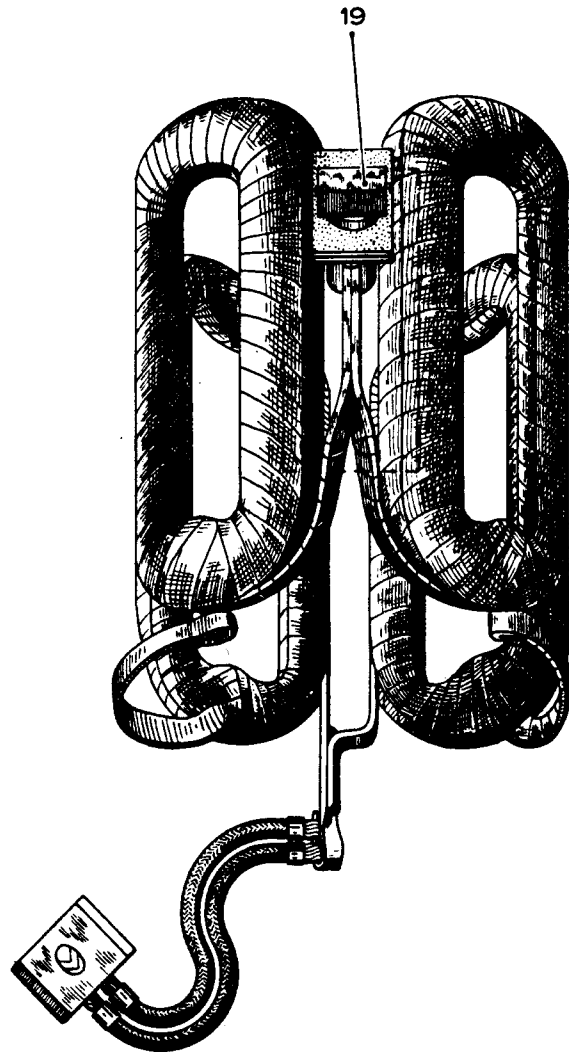
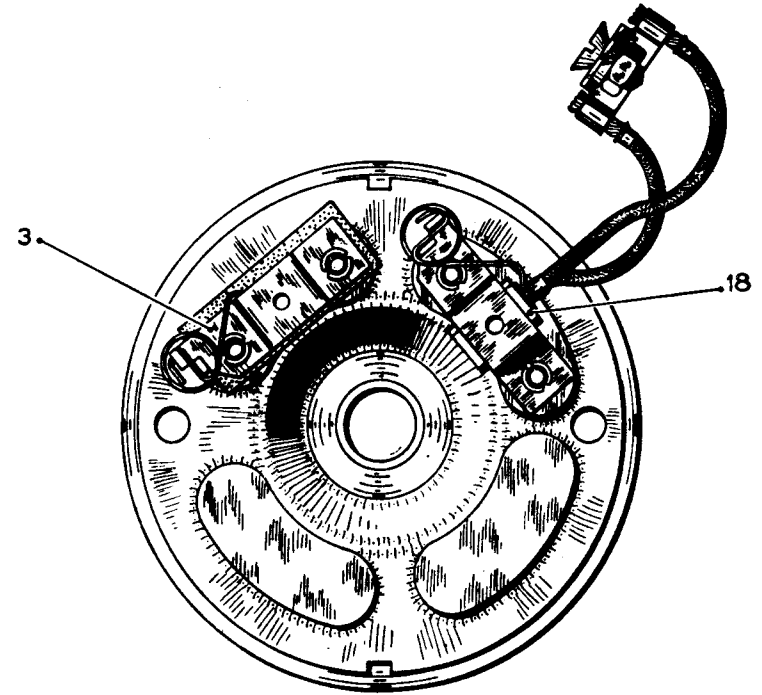
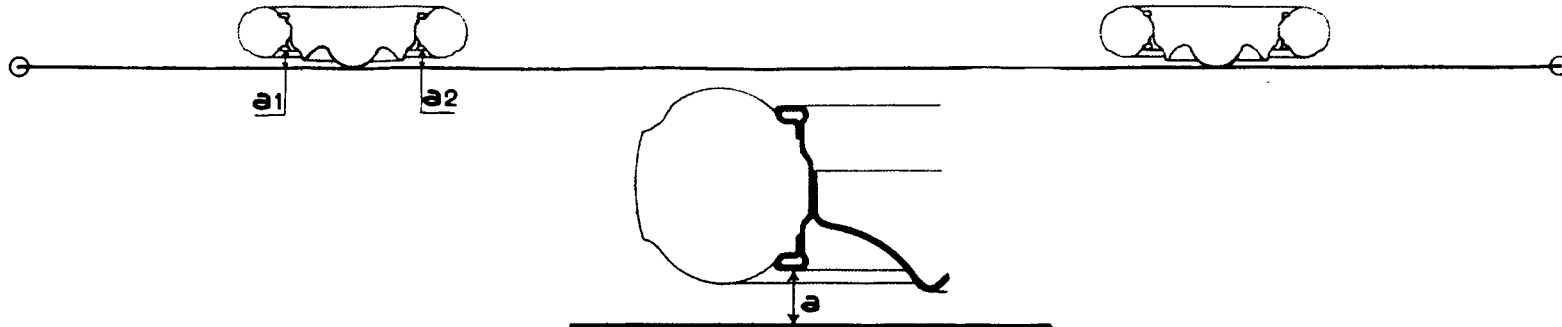
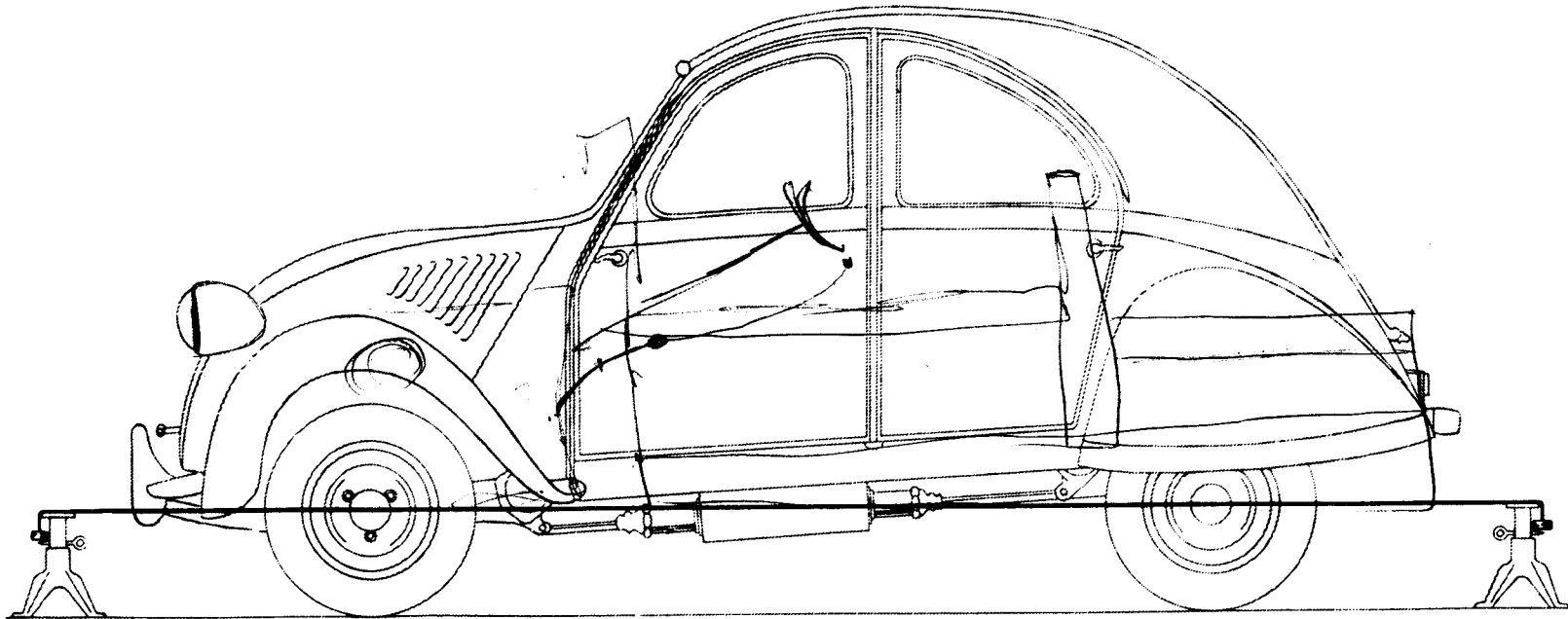

Fig. 2 - BRUSH ASSEMBLY



— CHECKING CASTER AND CAMBER ANGLE OF PIVOTS —

ALIGNMENT OF FRONT AND REAR WHEELS



— CHECKING CASTER AND CAMBER ANGLE OF PIVOT —

Fig. 1 FIRST CHECK

Fig. 2 SECOND CHECK

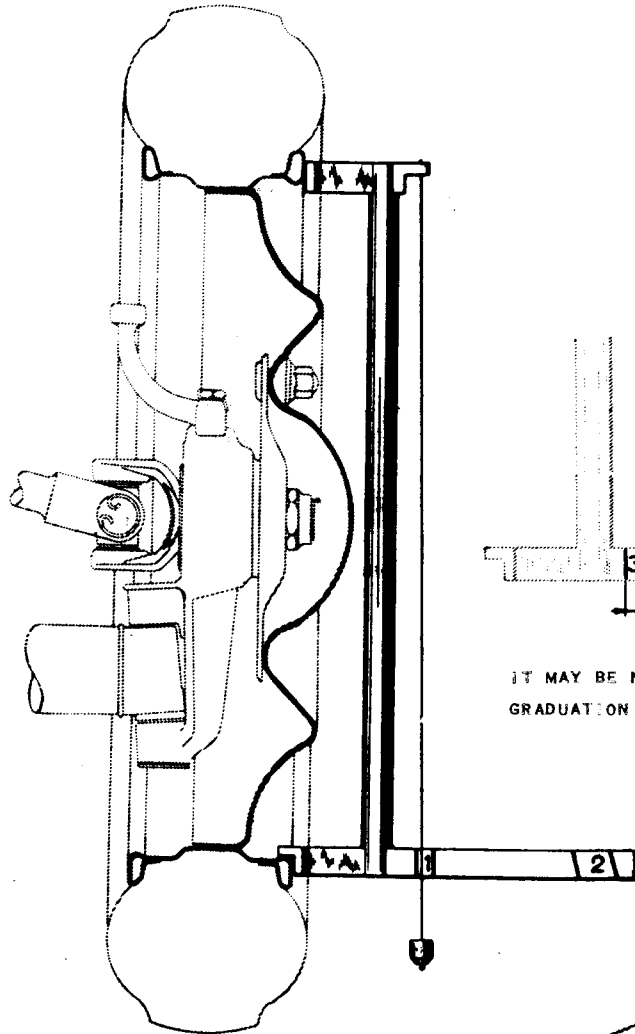

CHECKING FIXTURE

Sold under No. 2315-VA

Fig 3

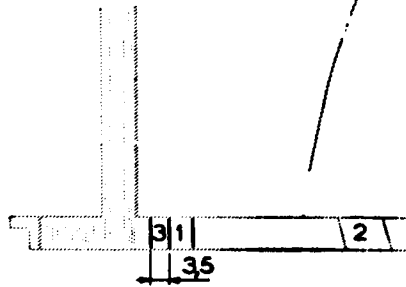

IT MAY BE NECESSARY TO ADD
GRADUATION ON 3 TO THE FIXTURE

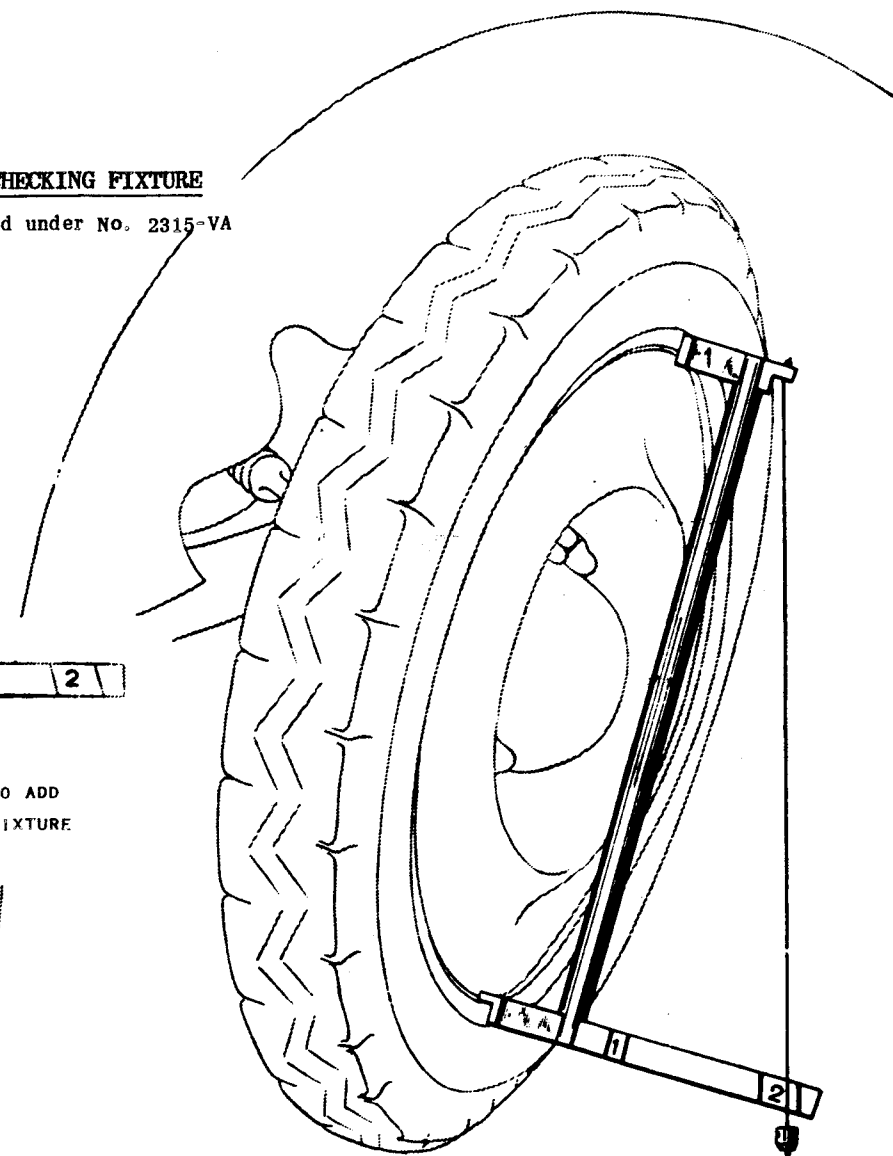

— REAR AXLE —

— CHECKING POSITION OF ARMS —

UTILIZATION

Fig. 1

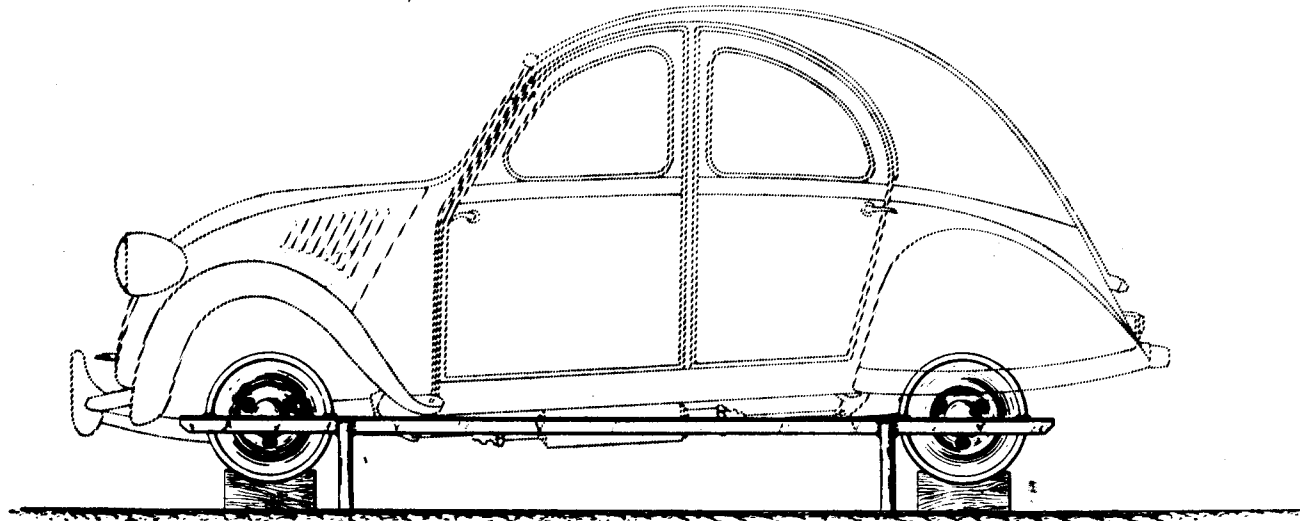
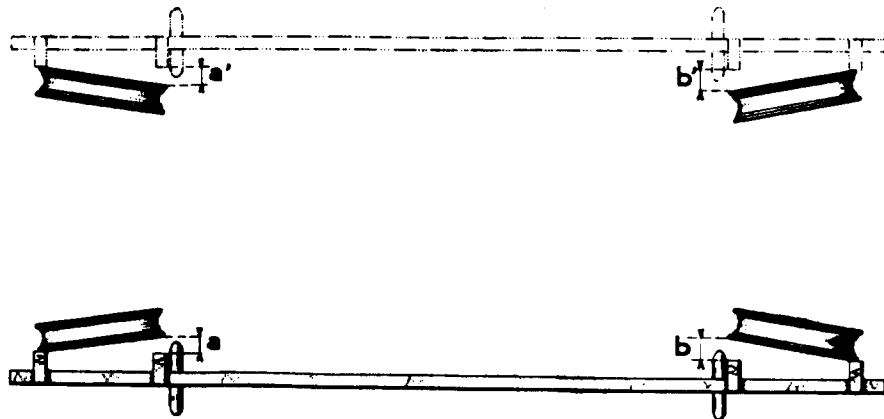

Fig. 2



— CHECKING POSITION OF ARMS —

TOOLS

Fig 1 RIM MR. 3756 22

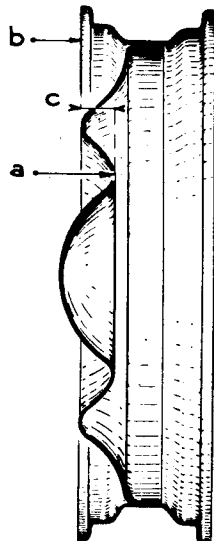

MODIFICATIONS CARRIED OUT ON 4 RIMS OF VAN AU (BM-135x400 3-30)

1. TRUE UP THE FACE a
2. TRUE UP THE EXTERIOR FACE b SO AS TO OBTAIN ONE SIDE c EQUAL ON THE 4 RIMS.

Fig. 2 GAUGE MR. 3756 20

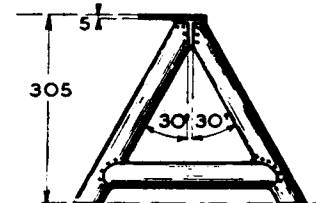
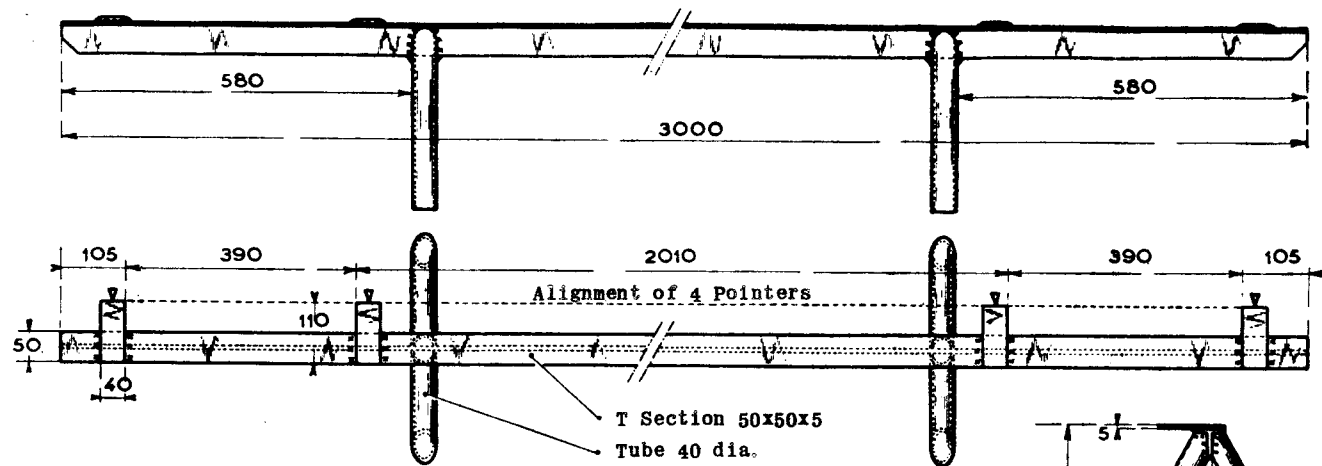
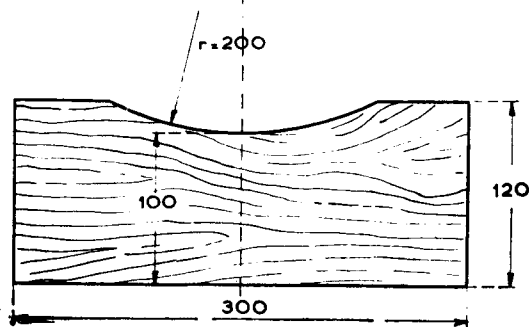

Fig. 3

4 BLOCKS MR. 3756 21 (Hard Wood)



— CHECKING VALVE TIMING —

Fig. 1

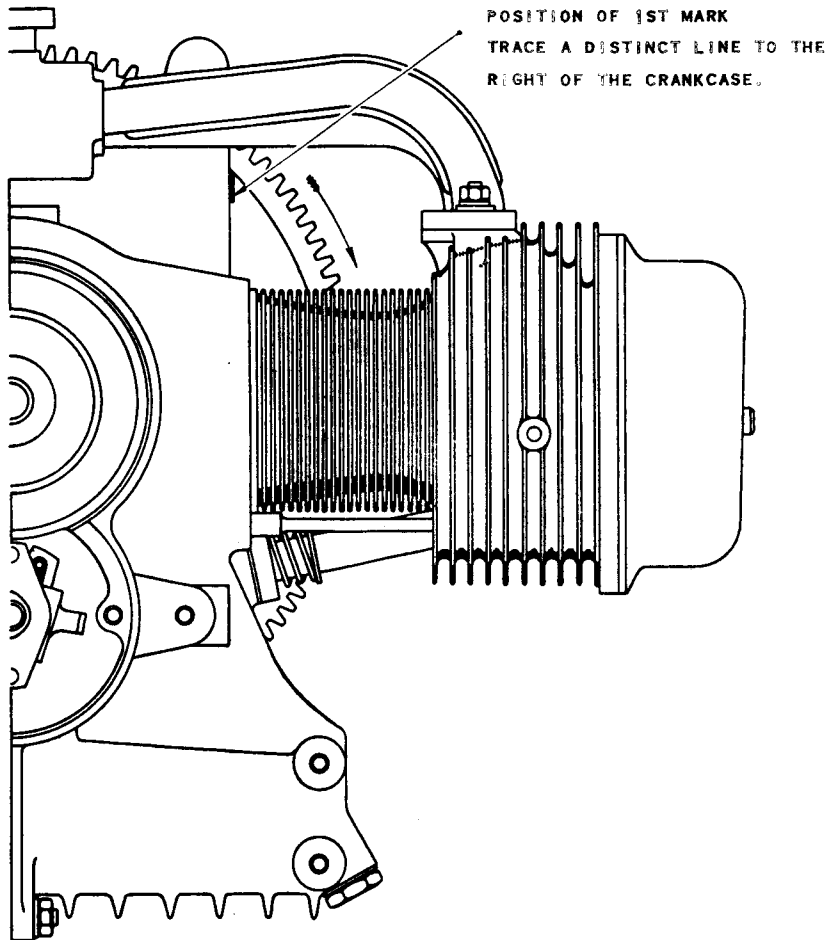
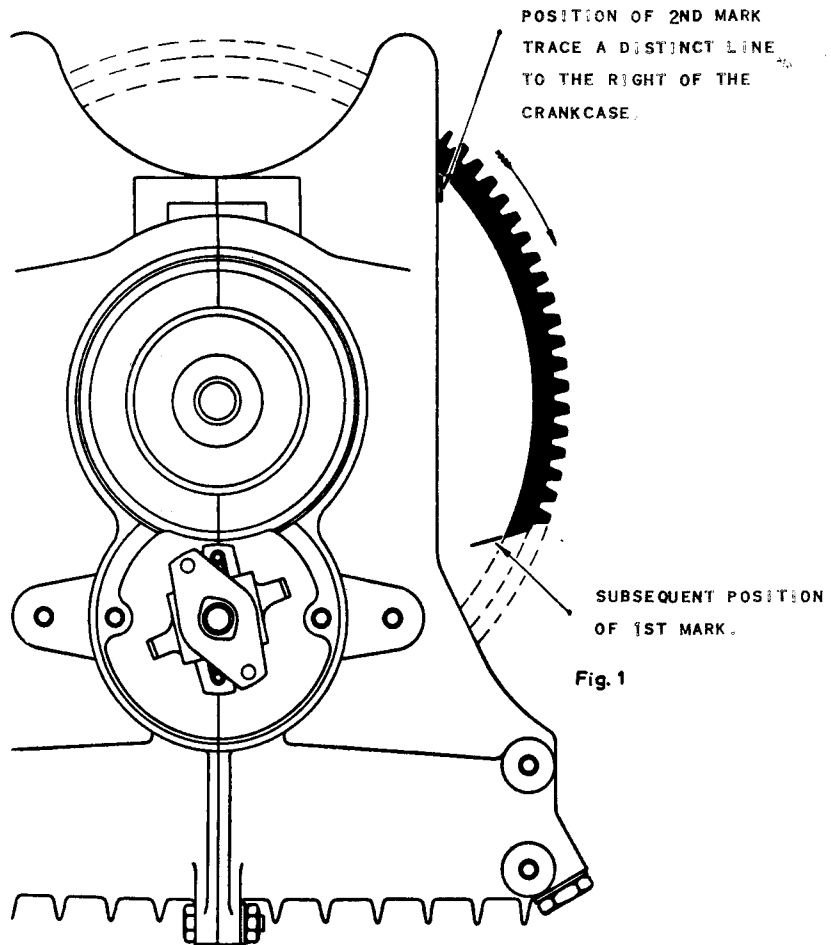

Fig. 2



— ADJUSTMENTS —

— CHECKING HEIGHTS —

Fig. 1 - USE OF GAUGE

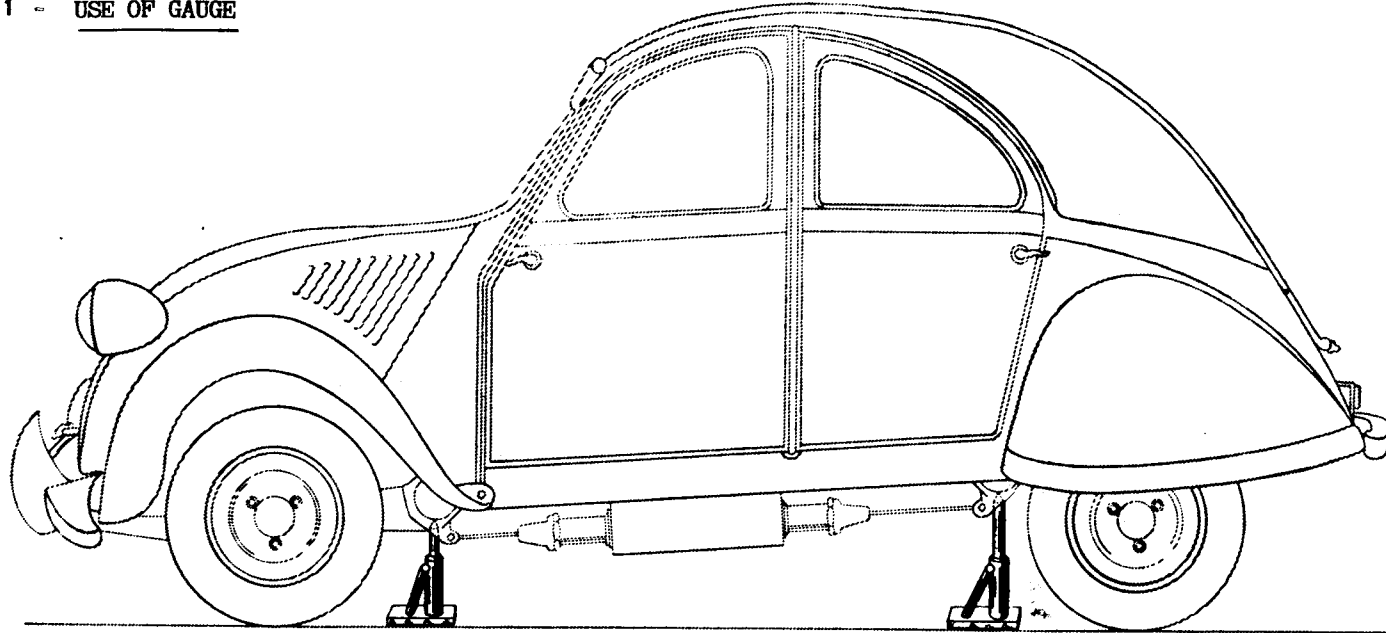

Fig. 2 - POSITION OF GAUGE

Fig. 3 - GAUGE

Sold under No. 2303-VA



USE WITH THE GAUGE 2300-T

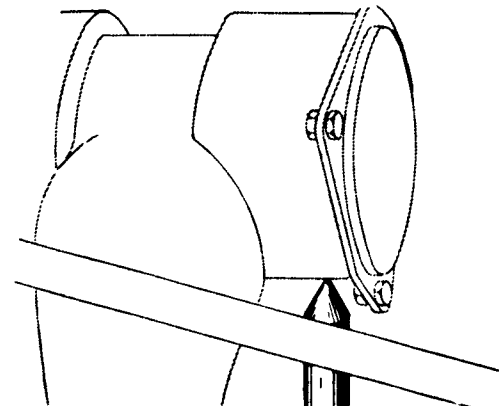

— ADJUSTMENTS —

— CHECKING WHEELS —

Fig. 1 — PUTTY TO BALANCE HEAVY PART

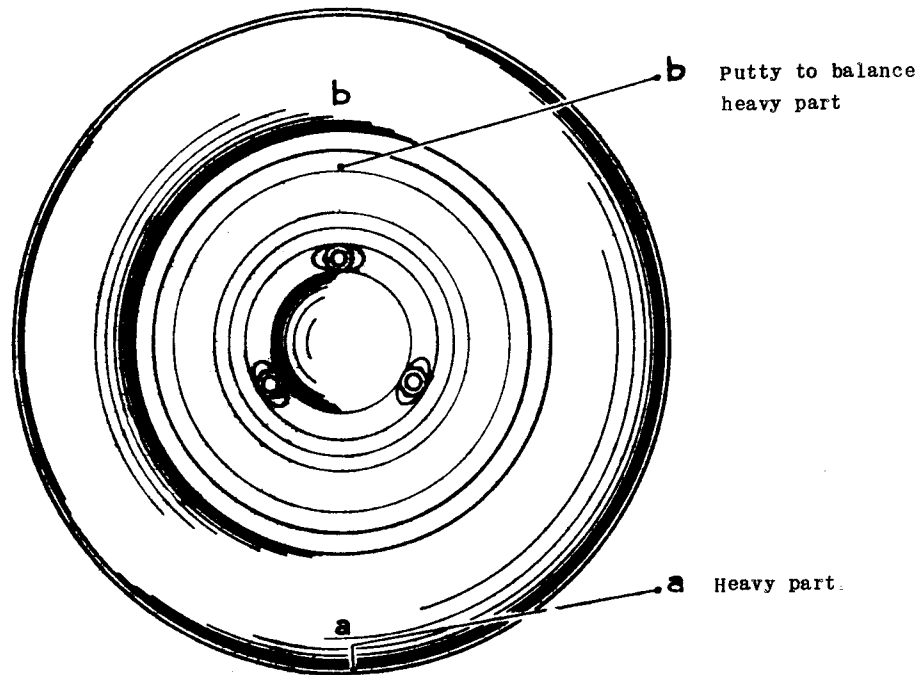

Fig. 2 — USE OF FIXTURE MR. 3396-10

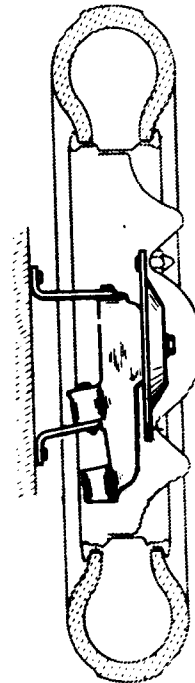

Fig. 3 — POSITION OF BALANCE WEIGHT

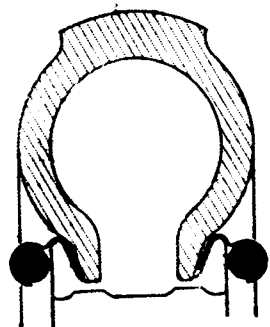
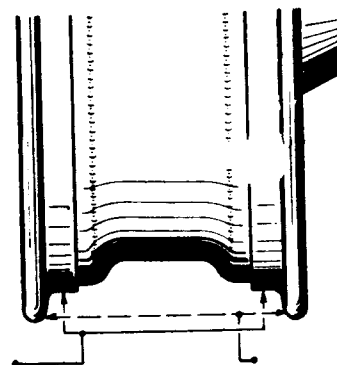

Fig. 4 — CHECKING DISTORTION OF RIM



CHECKING ECCENTRICITY

CHECKING DISTORTION

ADJUSTMENTS

CHECKING BALANCE OF WHEELS

IMPORTANT NOTE: IN ORDER TO OBTAIN THE FIXTURE MAXIMUM SENSITIVITY THE BALL RACETS SHOULD BE LUBRICATED WITH THIN VASELINE ONLY. THE FIXTURE MUST BE PERFECTLY BALANCED.

Fig. 1 FIXTURE MR 3396 90

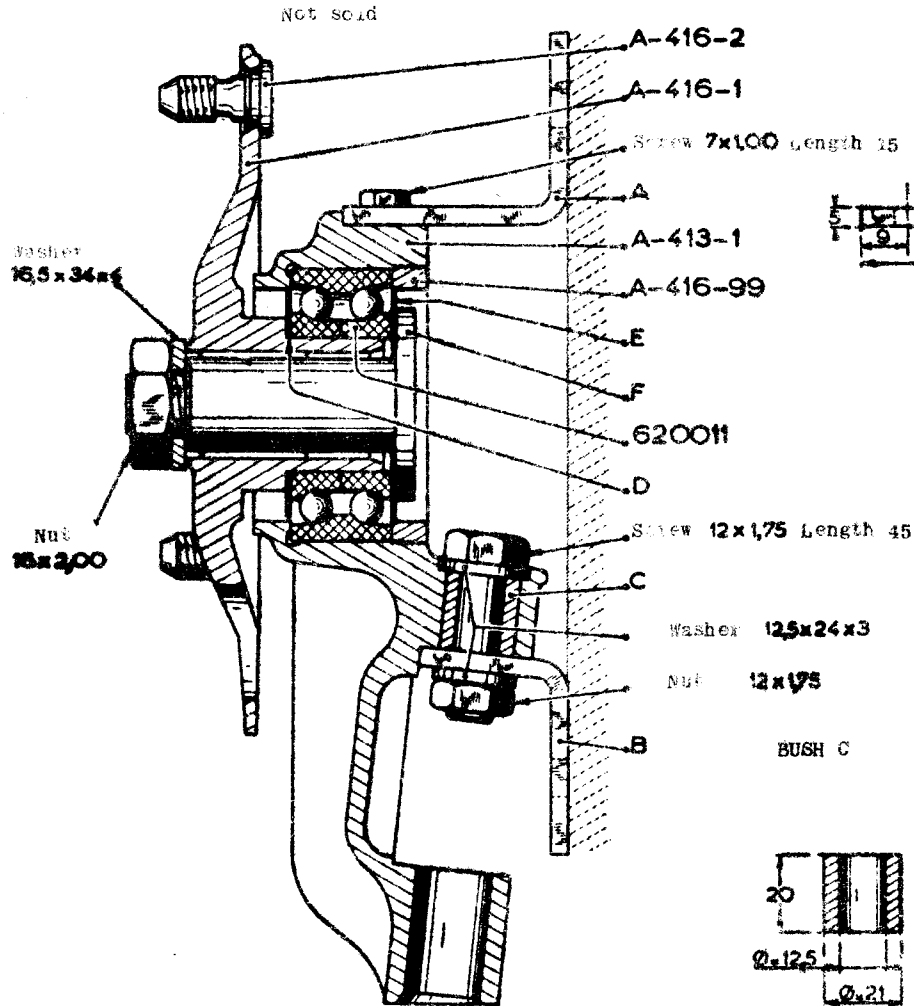

Fig. 2 FIXING BRACKETS

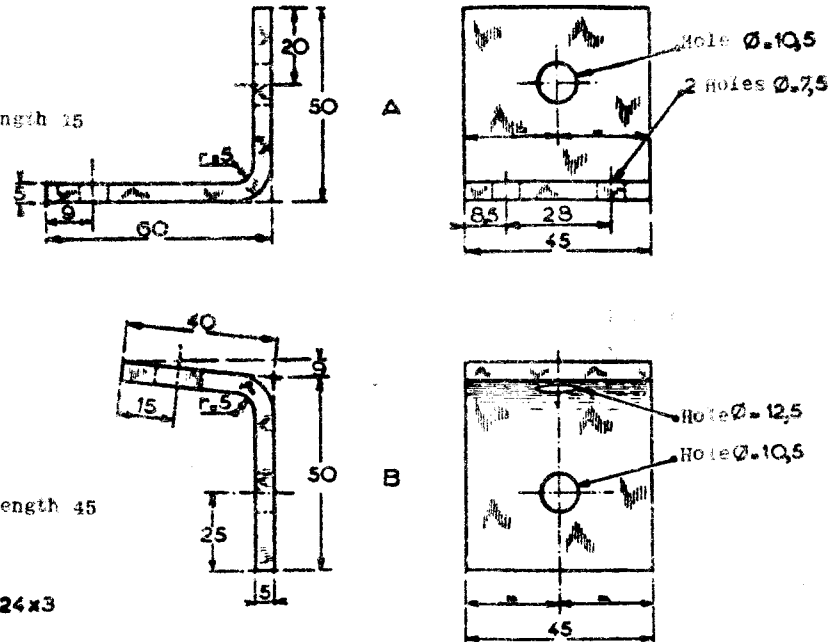
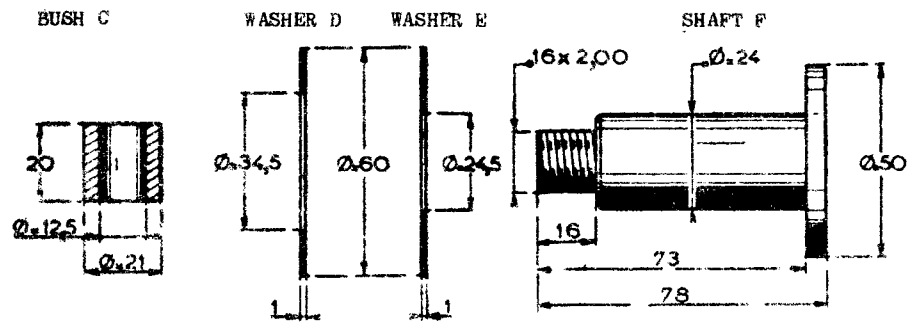

Fig. 3 DETAILS OF ASSEMBLY



ADJUSTMENTS

HEADLAMP ADJUSTMENT

Fig. 1 - PANEL MR. 1572

Not sold

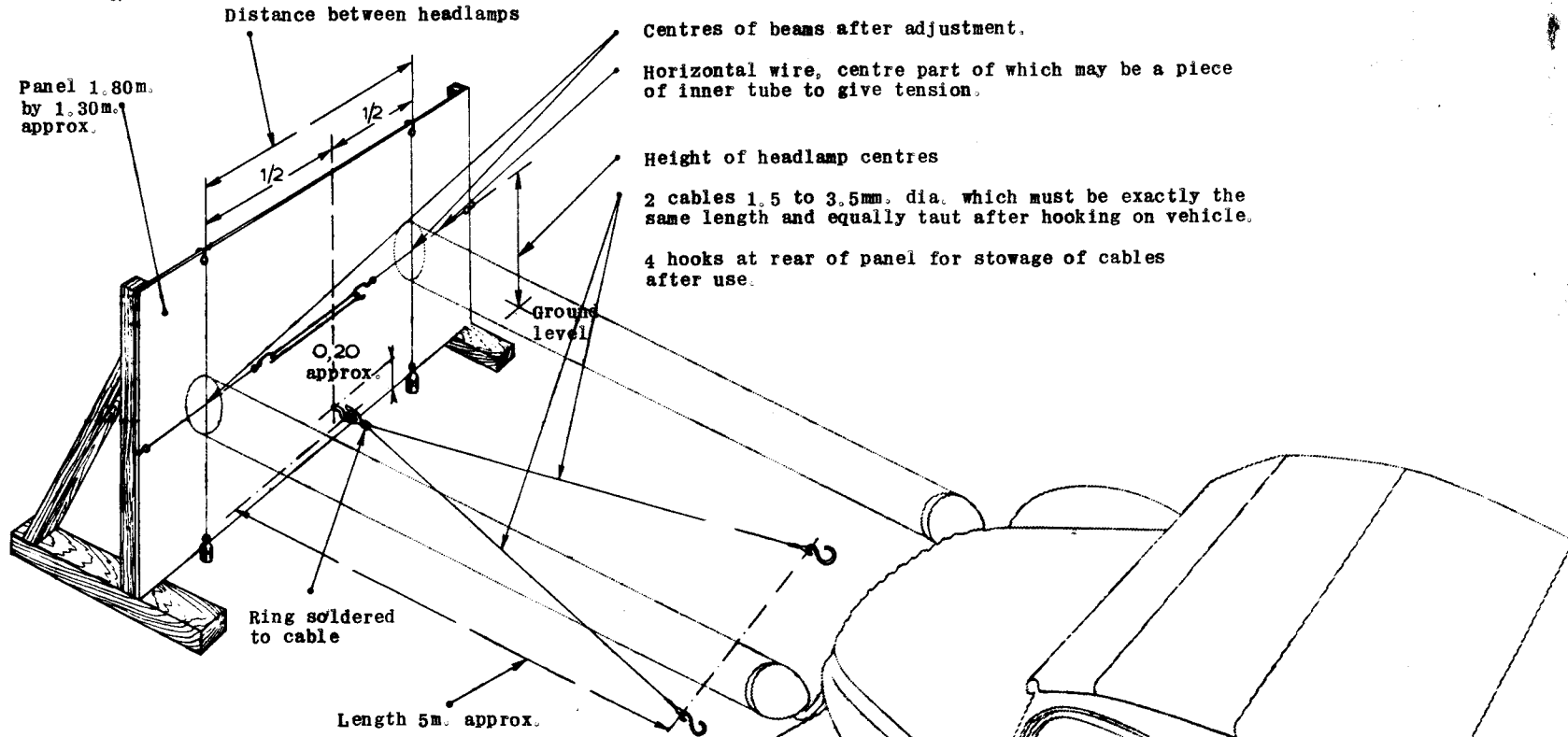
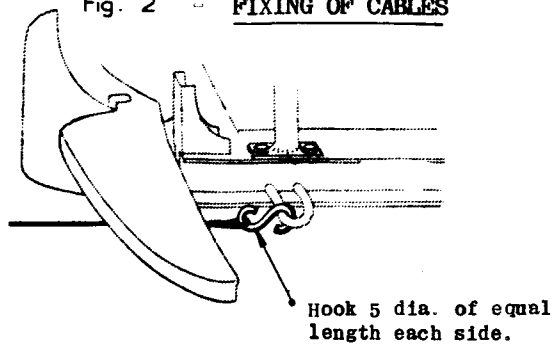
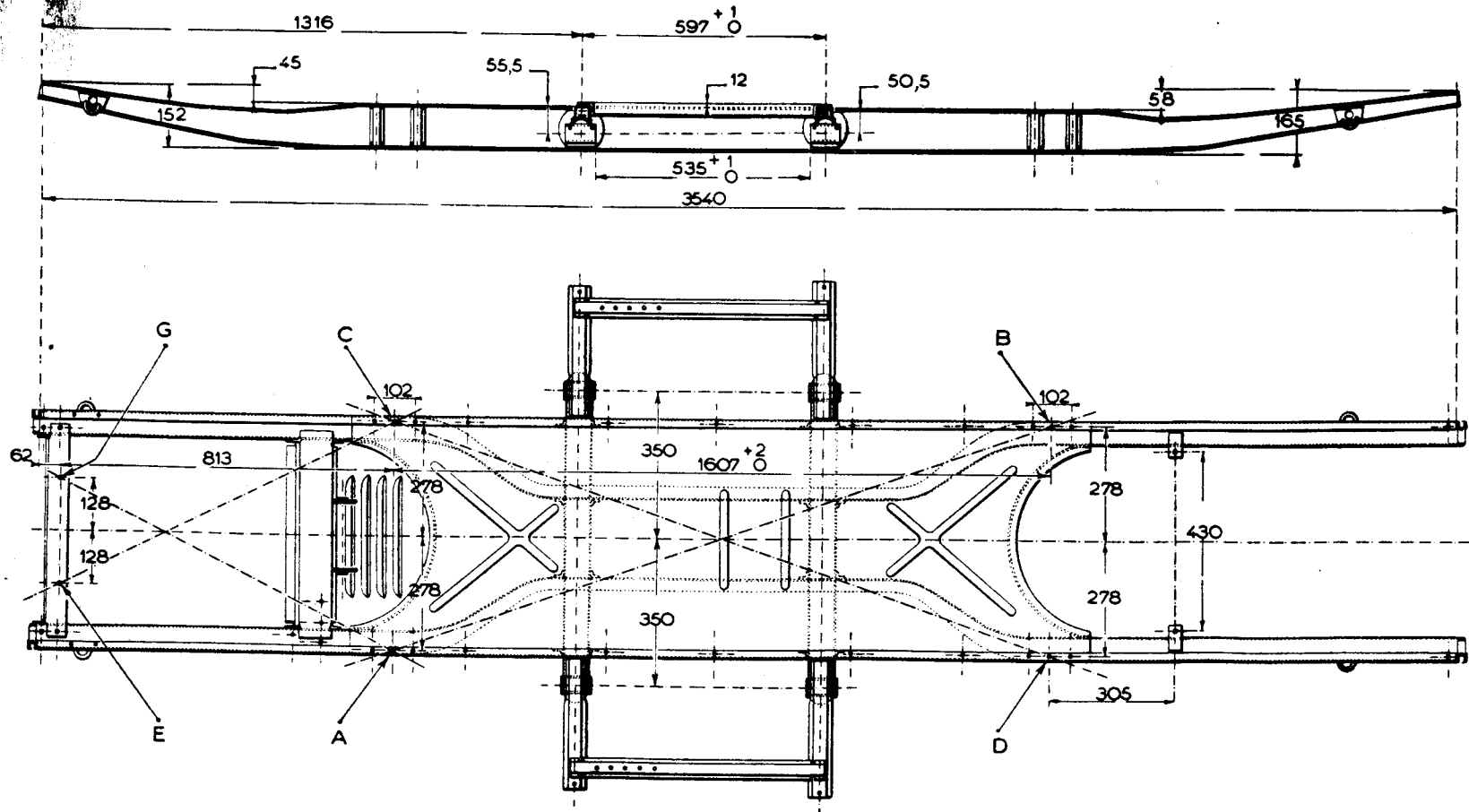

Fig. 2 - FIXING OF CABLES



CHASSIS

PRINCIPAL DIMENSIONS



CHASSIS

PRINCIPAL DIMENSIONS

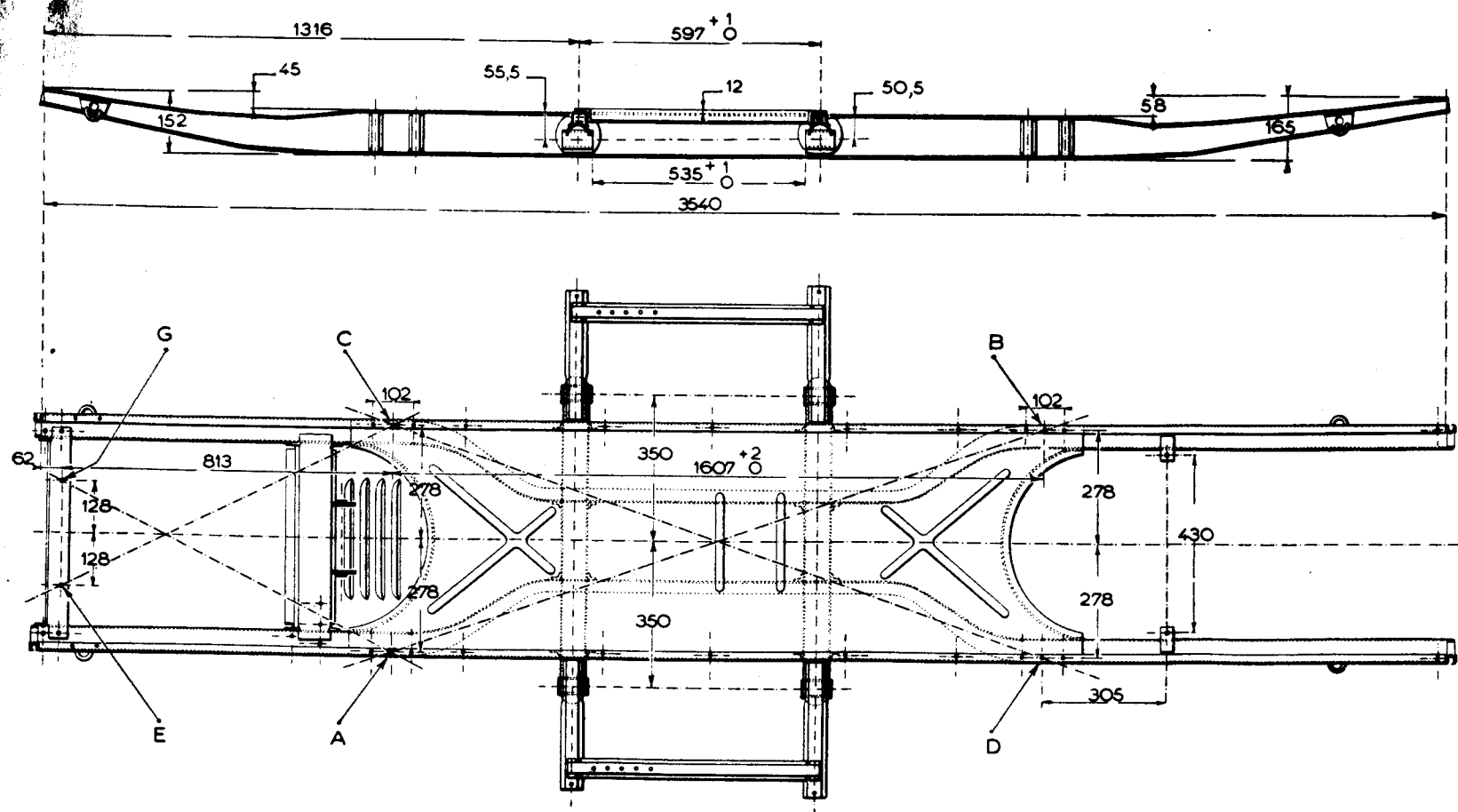

CHASSIS

CHECKING SIDEMEMBERS

Fig. 1 - USE OF TEMPLATE

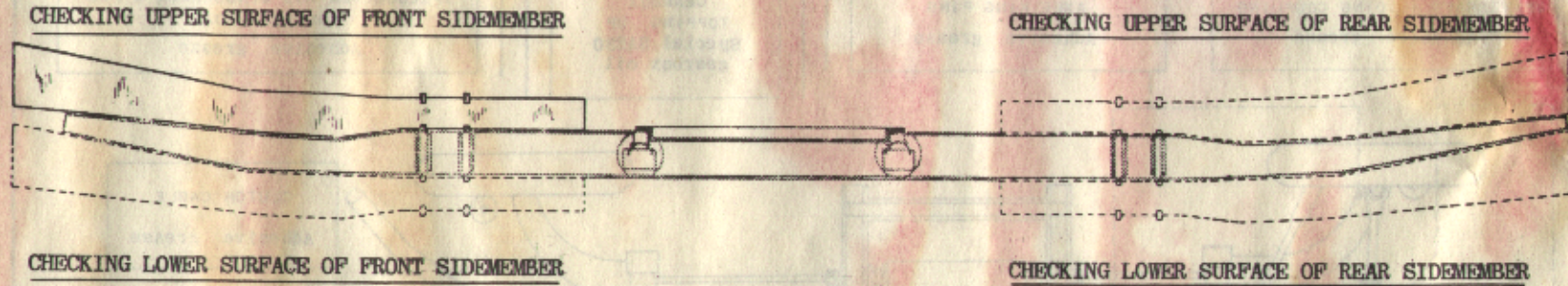
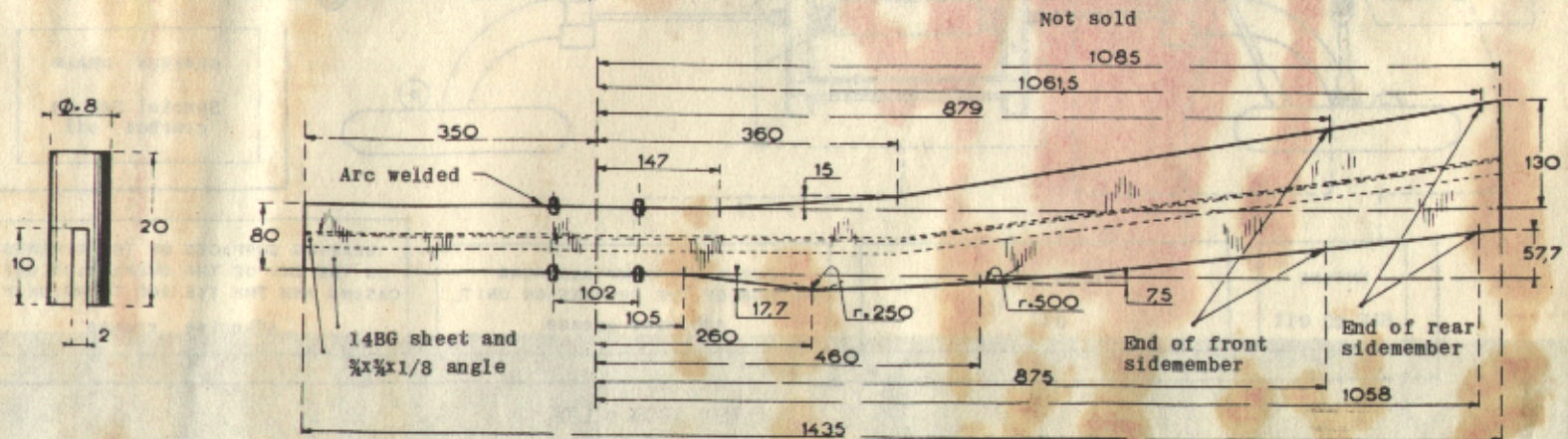

Fig. 2 - TEMPLATE MR. 3747



— LUBRICATION —

— LUBRICATION POINTS —

EVERY 1200 MILES

EVERY 4500 MILES

EVERY 12000 MILES

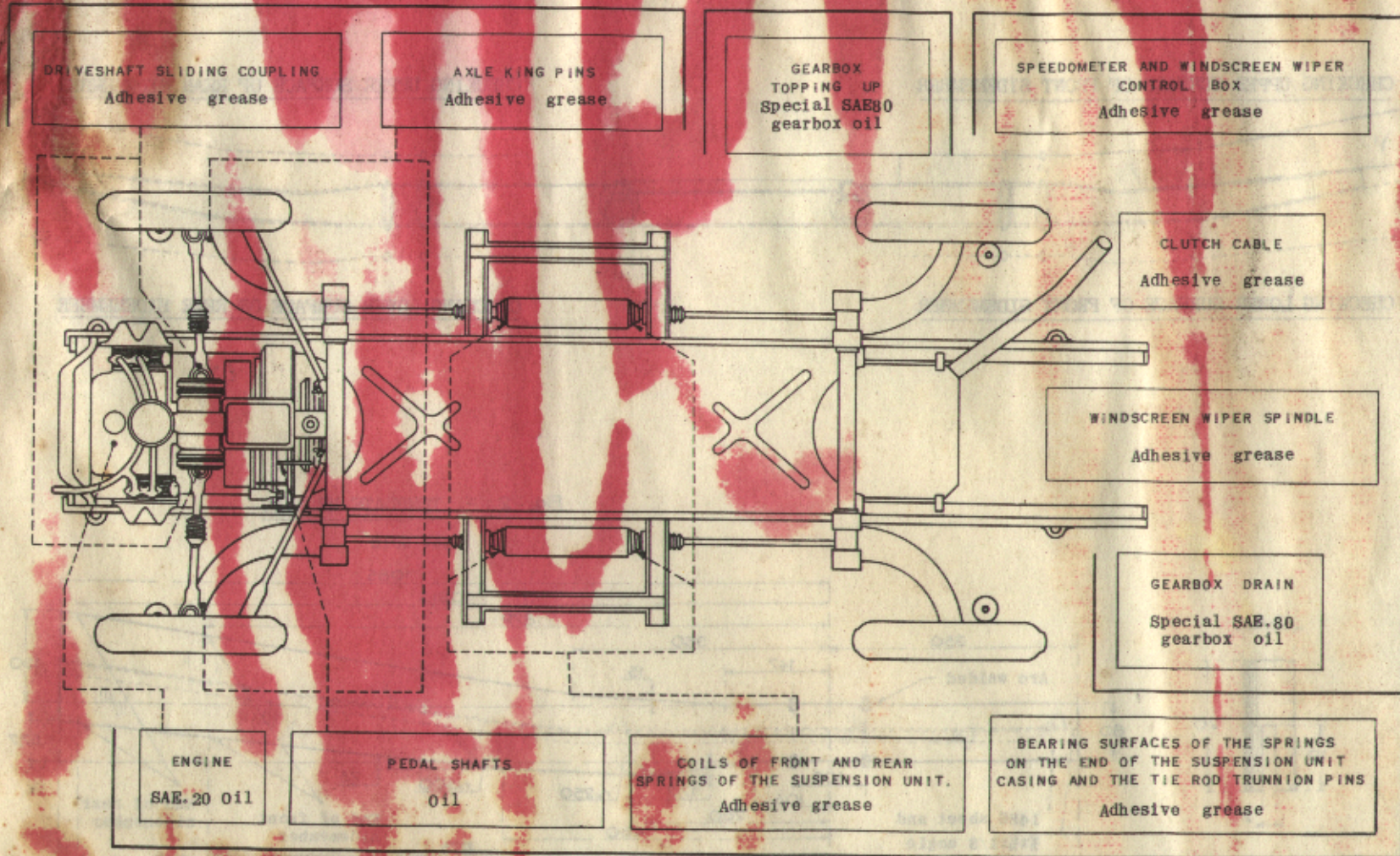

EVERY 2000 MILES